

TU81/TA81

Technical Manual

EK-TUA81-TM-002

TU81/TA81

Technical Manual

1st Edition, January 1985
2nd Edition, November 1985

Copyright © 1985 by Digital Equipment Corporation
All Rights Reserved.
Printed in U.S.A.

The reproduction of this material, in part or whole, is strictly prohibited. For copy information, contact the Educational Services Department, Digital Equipment Corporation, Maynard, Massachusetts, 01754.

The information in this document is subject to change without notice. Digital Equipment Corporation assumes no responsibility for any errors that may appear in this document.

LEGAL NOTICE: TMSCP and STI protocols and documentation are the proprietary information of Digital Equipment Corporation. UNIBUS/Q-BUS/BI-BUS port drivers and documentation for MSCP/TMSCP products are also proprietary information of Digital Equipment Corporation.

The following are trademarks of Digital Equipment Corporation, Maynard, Massachusetts.

digital [™]	DIBOL	Rainbow	VAX
DEC	MASSBUS	RSTS	VMS
DECmate	PDP	RSX	VT
DECUS	P/OS	RT	Work Processor
DECwriter	Professional	UNIBUS	

CONTENTS

SECTION 1 GENERAL DESCRIPTION

- 1.1 General 1-1
- 1.2 Functional Description 1-8
 - 1.2.1 Transport Control System 1-8
 - 1.2.2 Interface System 1-8
 - 1.2.2.1 TU81 Interface 1-8
 - 1.2.2.2 TA81 Interface 1-9
 - 1.2.3 Power Supply 1-10
 - 1.2.4 874 Power Controller 1-10
- 1.3 Physical Description 1-10
 - 1.3.1 Tape Deck - Top 1-10
 - 1.3.1.1 Supply Reel 1-12
 - 1.3.1.2 Take-Up Reel 1-12
 - 1.3.1.3 Air Bearings 1-12
 - 1.3.1.4 Magnetic Head Assembly 1-12
 - 1.3.1.5 Tape Cleaner 1-12
 - 1.3.1.6 BOT/EOT Assembly 1-12
 - 1.3.1.7 File Protect 1-12
 - 1.3.1.8 Power Supply Circuit Breaker 1-13
 - 1.3.1.9 Top Cover Interlock 1-13
 - 1.3.2 Tape Deck - Bottom 1-13
 - 1.3.2.1 Tape Deck Latch 1-13
 - 1.3.2.2 Power Supply 1-13
 - 1.3.2.3 Pneumatic Pump and Filter/Regulator System . 1-13
 - 1.3.2.4 Power Amplifier Module 1-15
 - 1.3.2.5 Cooling Fan Assembly 1-15
 - 1.3.2.6 Logic Cages 1-15
 - 1.3.2.7 Reel Motors 1-15
 - 1.3.3 Control Panel (Front Door) 1-15
- 1.4 Equipment Configuration 1-16
 - 1.4.1 Equipment ID Plate/Serial Tag 1-16

SECTION 2 INSTALLATION AND CHECKOUT

SECTION 3 OPERATION

3.1	General	3-1
3.2	Control Panel	3-1
3.3	Operating Procedure	3-7
3.3.1	Inserting Write Enable Ring	3-7
3.3.2	Tape Threading and Loading	3-8
3.3.3	Tape Unloading	3-10
3.3.3.1	Manual Mode	3-10
3.3.3.2	On-line Mode	3-10
3.3.4	Pump Shutdown	3-10
3.4	Operator Corrective Actions	3-11

SECTION 4 THEORY

4.1	General Description	4-1
4.2	Physical Description	4-3
4.2.1	Power Supply	4-3
4.2.2	Tension/Speed Control	4-3
4.2.3	Magnetic Head	4-4
4.2.4	Electronic Modules	4-4
4.2.4.1	Formatter/Interface Logic Set	4-4
4.2.4.2	Read/Write/Servo Logic Set	4-5
4.3	Power Supply	4-5
4.3.1	General Description	4-5
4.3.2	Physical Description	4-5
4.3.2.1	Voltage Select PC Board	4-8
4.3.2.2	Power Supply Control PC Board	4-8
4.3.2.3	Power Supply Main PC Board	4-8
4.3.3	Power Supply Functional Description	4-9
4.3.3.1	Input Power Selection	4-9
4.3.3.2	Standby Voltage Generation	4-10
4.3.3.3	Power-On Sequence	4-12
4.3.3.4	Switching Converter	4-14
4.3.3.5	DC Voltages	4-15
4.3.3.6	Low Voltage/Over-Voltage Detection	4-16
4.3.3.7	Power Supply Shut-Down	4-16
4.4	Pneumatic System	4-17
4.4.1	Functional Description	4-17
4.4.2	Pneumatic System Operational Description	4-18
4.5	Servo/Control Module	4-20
4.5.1	Introduction	4-20
4.5.1.1	Formatter Commands/Responses	4-20
4.5.1.2	Transport Control/Monitoring	4-20
4.5.1.3	Control Panel Command Execution	4-20
4.5.1.4	Tape Motion/Servo Control	4-20
4.5.2	Microprocessor	4-21
4.5.3	Velocity Servo	4-23
4.5.4	Tension Servo	4-25
4.6	Power Amplifier Module	4-27

4.7	Write Driver Module	4-31
4.7.1	Write Control	4-31
4.7.2	Write Driver LSI	4-33
4.7.3	Degauss	4-34
4.8	Read Amplifier Module	4-35
4.8.1	Read Recovery	4-35
4.8.2	Automatic Gain Control (AGC)	4-37
4.8.3	Loop Data	4-38
4.9	Formatter Modules	4-38
4.9.1	I/O Command Translation	4-38
4.9.2	Data Conversion	4-38
4.9.2.1	PE Data Conversion	4-40
4.9.2.2	GCR Data Conversion	4-40
4.9.3	Tape Control and Identifier Mark Generation and Deletion	4-40
4.9.3.1	PE Data Block Format	4-40
4.9.3.2	GCR Data Block Format	4-44
4.9.4	Error Detection and Correction	4-50
4.9.4.1	PE Mode	4-50
4.9.4.2	GCR Mode	4-51
4.10	Interface Controller Modules	4-54
4.10.1	TMSCP Interface Controller Module	4-54
4.10.1.1	Commands	4-57
4.10.1.2	Status Information	4-64
4.10.1.3	ASCII Port Printout of Sense Byte Information	4-66
4.10.2	STI Interface Controller Module	4-85
4.11	Interface and Timing Considerations	4-86
4.11.1	Motion Characteristics	4-86
4.11.2	Start/Stop Mode	4-86
4.11.2.1	Read Operations	4-86
4.11.2.2	Write Operations	4-86
4.11.2.3	Other Start/Stop Motion Characteristics	4-86
4.11.3	Streaming Modes (25 ips and 75 ips)	4-87
4.11.3.1	Case 1 (Non-Stop)	4-89
4.11.3.2	Case 2 (Momentary Stop)	4-89
4.11.3.3	Case 3 (Wait For Command)	4-93
4.11.4	25 ips Mode Control	4-95

SECTION 5 MAINTENANCE

5.1	General	5-1
5.2	Access to Components	5-1
5.2.1	Top Cover Interlock Switch Defeat	5-3
5.3	Removal/Replacement Procedures	5-5
5.3.1	Drive Cover Assembly	5-6
5.3.2	Tape Cleaner Assembly	5-8
5.3.3	Top Cover Interlock Switch	5-10
5.3.4	File Protect Sensor	5-12
5.3.5	EOT/BOT Sensor Assembly	5-14
5.3.6	Take-Up Reel Hub Assembly	5-16

5.3.7	Take-Up Reel Motor Assembly	5-18
5.3.8	Supply Reel Hub Assembly	5-20
5.3.9	Supply Reel Motor Assembly	5-21
5.3.10	Supply Motor Tach and Sensor	5-25
5.3.11	Air Bearing Sensors	5-27
5.3.12	Supply and Take-Up Air Bearing Spring Guide ..	5-30
5.3.13	Pneumatic Pump Assembly	5-32
5.3.14	Pressure Regulator and Filter Assembly	5-34
5.3.15	Magnetic Head Assembly	5-36
5.3.16	Control Panel Assembly	5-40
5.3.17	Cooling Fan Assembly	5-42
5.3.18	Power Supply	5-43
5.3.19	Write Driver/Read Amplifier/Servo Control Modules	5-48
5.3.20	Formatter Read Module	5-58
5.3.21	Formatter Write Module	5-60
5.3.22	Interface Controller Module	5-63
5.3.23	Power Amplifier Module	5-66
5.3.24	Capacitor Assembly	5-68
5.4	TU81/TA81 Diagnostics and Troubleshooting	5-70
5.4.1	General	5-70
5.4.2	Resident Diagnostics	5-70
5.4.2.1	Corrective Fault Code Matrix	5-72
5.4.2.2	Preliminary Troubleshooting	5-73
5.4.2.3	Diagnostic Mode Operating Instructions	5-76
5.4.2.4	Resident Test Descriptions	5-76
5.4.3	Field Service Diagnostic Listing	5-81
5.5	TU81 VAX-Executable Diagnostics	5-81
5.5.1	M8739 Status Checking	5-81
5.5.1.1	TU81 Add-On Configuration	5-81
5.5.1.2	On-Line Operation Failure	5-81
5.5.2	VAX Front-End Diagnostic (EVMBB)	5-81
5.5.2.1	DEFAULT Section	5-82
5.5.2.2	MANUAL Section	5-82
5.5.2.3	FAULT Section	5-83
5.5.3	VAX Data Reliability Diagnostic (EVMBB)	5-83
5.5.4	Basic Operating Instructions for VAX-Based Diagnostics	5-84
5.5.5	System Exerciser	5-86
5.5.6	EVMBB Sample Error Printout	5-86
5.6	TU81 PDP-11-Executable Diagnostics	5-86
5.6.1	Operating Instructions for PDP-11-Based Diagnostics	5-87
5.6.2	CZTU2 Front-End Functional Diagnostic	5-88
5.6.3	CZTU1 Data Reliability Test	5-88
5.6.4	CXTUCA DEC/X11 Module	5-89
5.7	Maintenance Indicators and Fault/Error Codes ...	5-89
5.8	Operating System Error Log Decoding and Troubleshooting	5-94
5.9	TA81 HSC-Executable Diagnostics	5-95
5.9.1	ILTAPPE	5-95
5.9.2	ILEXER	5-96

5.10	ASCII Port Diagnostics	5-98
5.10.1	Port Access	5-100
5.10.2	Diagnostic Commands	5-102
5.10.3	Message Format	5-102
5.10.4	Special Diagnostic Test 27	5-103

APPENDIX A TU81 SYSTEM INTERFACE

A.1	TMSCP Overview	A-1
A.2	Subsystem Overview	A-1
A.3	Software/Firmware Overview	A-3
A.3.1	Host Architecture	A-3
A.3.2	I/O Controller Architecture	A-4
A.4	Host-to-Controller Communications	A-7
A.4.1	Connection States	A-7
A.4.2	Flow Control	A-9
A.5	M8739 LESI Adapter	A-10
A.5.1	Data Transfers	A-10
A.5.2	Interrupts	A-12
A.5.3	UNIBUS Registers	A-12
A.6	TMSCP Controller Module	A-13
A.7	The Unit	A-13

APPENDIX B

B.1	Tape Transport Configuration Selection	B-1
-----	--	-----

APPENDIX C

APPENDIX D TA81 SYSTEM INTERFACE

D.1	STI Overview	D-1
D.2	Subsystem Overview	D-1
D.3	STI Bus Overview	D-2
D.4	STI Communications	D-2
D.4.1	State Frames	D-3
D.4.2	Message Frames	D-5

FIGURES

1-1A	TU81 Tape Subsystem	1-3
1-1B	TA81 Tape Subsystem	1-4
1-2A	TU81 Tape Subsystem Block Diagram	1-4A
1-2B	TA81 Tape Subsystem Block Diagram	1-4B
1-3	Component Location - Top View	1-11
1-4	Tape Deck Component Locations - Rear View	1-14
1-5	Equipment Identification Plate	1-16
3-1	TU81 Control Panel	3-1
3-2	TA81 Control Panel	3-2
3-3	Control Panel Functions	3-2
3-4	Write Enable Ring	3-7
3-5	Tape Path	3-9
4-1A	TU81 Functional Block Diagram	4-2A
4-1B	TA81 Functional Block Diagram	4-2B
4-2	Major Power Supply Components	4-6
4-3	Power Supply Block Diagram	4-7
4-4	Voltage Select PC Board	4-9
4-5	Cooling Fan Wiring	4-10
4-6	Standby Voltage Generation	4-11
4-7	Power-On Sequence Flowchart	4-13
4-8	High Voltage Generation	4-14
4-9	Switching Converter Circuit	4-15
4-10	Vacuum and Pressure Distribution	4-17
4-11A	Pneumatic Pump Wiring 120 Vac Configuration ...	4-19
4-11B	Pneumatic Pump Wiring 220 Vac Configuration ...	4-19
4-12	Servo/Control Block Diagram	4-22
4-13	Velocity Servo - Simplified	4-24
4-14	Tension Servo - Simplified	4-25
4-15	Power Amplifier Block Diagram	4-27
4-16	Power Amplifier Waveforms	4-28
4-17	H-Bridge Switching	4-29
4-18	Switched +5 Volts	4-30
4-19	Write Control Block Diagram	4-32
4-20	Write Driver Block Diagram	4-33
4-21	Degauss Waveform	4-34
4-22	Read Amplifier Block Diagram	4-36
4-23	I/O Command Translation	4-39
4-24	Phase Encoding	4-41
4-25	GCR Conversion	4-42
4-26	GCR Translation Values	4-42
4-27	NRZI Encoding	4-43
4-28	PE Tape Format	4-43
4-29	GCR Tape Format	4-45
4-30A	Detail of GCR Tape Format (PREAMBLE)	4-46
4-30B	Detail of GCR Tape Format (RESYNC)	4-47
4-30C	Detail of GCR Tape Format (END MARK)	4-49
4-30D	Detail of GCR Tape Format (POSTAMBLE)	4-49
4-31	Phase Error Window - PE Mode	4-52
4-32	Phase Error Window - GCR Mode	4-53
4-33	Block Diagram, Host/Transport Interface	4-55
4-34	TMSCP/Formatter Interface	4-56
4-35	Mode Change Command	4-63

4-36	Read Data/Status Line Selection	4-65
4-37A	ASCII Port Printout	4-67
4-37B	ASCII Port Printout	4-68
4-37C	ASCII Port Printout	4-69
4-38	Streaming Mode Velocity Diagram	4-88
4-39	Tape Motion Control - Case 1	4-90
4-40	Velocity Profile - Case 2	4-91
4-41	Tape Motion Control - Case 2	4-92
4-42	Velocity Profile - Case 3	4-93
4-43	Tape Motion Control - Case 3	4-94
5-1	TU81/TA81 Maintenance Access	5-2
5-2	Cover Interlock Defeat Tool	5-4
5-2A	TU81 Cable Diagram	5-4A
5-2B	TA81 Cable Diagram	5-4B
5-3	Drive Cover	5-7
5-4	Tape Cleaner	5-8
5-5	Top Cover Interlock Switch (Maintenance View) .	5-10
5-6	File Protect Sensor Alignment	5-12
5-7	EOT/BOT Sensor	5-14
5-8	Take-Up Reel/Supply Reel Hub Assemblies	5-17
5-9	Take-Up Motor Assembly	5-19
5-10	Supply Motor Assembly	5-22
5-11	Tach Wheel/Sensor Alignment	5-25
5-12	Logic Cage	5-28
5-13	Air Bearing Sensors	5-29
5-14	Air Bearing Spring Guide	5-31
5-15	Pneumatic Pump Assembly	5-33
5-16	Filter Box Assembly	5-35
5-17	Magnetic Head Assembly	5-36
5-18	Magnetic Head Connectors	5-38
5-19	Control Panel Assembly	5-40
5-20	Cooling Fan Assembly	5-42
5-21	Power Supply Connectors	5-43
5-22	Power Supply (Rear Cabinet View)	5-44
5-23	Voltage Select Card	5-45
5-24	Power Terminal Strip TB-1	5-47
5-25	Write Driver/Read Amp/Servo Control Logic Cage	5-50
5-26	Removing Write Driver/Read Amp/Servo Control Modules	5-51
5-27	Write Driver Module Connectors	5-53
5-28	Read Amplifier Module Connectors	5-54
5-29	Servo/Control Module Connectors	5-55
5-30	Formatter Read/Formatter Write/Interface Controller Modules	5-59
5-31	Formatter Write Module	5-62
5-32A	TMSCP Interface Controller Module	5-64
5-32B	STI Interface Controller Module	5-64
5-33	Power Amplifier Module	5-67
5-34	Capacitor Assembly	5-68
5-35	Troubleshooting Chart	5-71
5-36	Power-On Health Check Flowchart	5-78
5-37	Error/Status Code Word Format	5-95
5-38	ASCII Port and EIA Cable	5-98

A-1	TU81 System Block Diagram	A-2
A-2	Software/Firmware Block Diagram	A-5
A-3	Communications Mechanism	A-8
A-4	M8739 LESI Adapter Block Diagram	A-11
A-5	TMSCP Interface Block Diagram	A-14
A-6	TMSCP Controller Block Diagram	A-15
B-1	Logic Module Locations with Tape Deck in Service Position	B-3
B-2	Formatter Write Module - Jumper Locations	B-4
B-3	Servo/Control Module - Jumper Locations	B-5
B-4	TMSCP Interface Module - Jumper Locations	B-6
B-5	STI Interface Module - Jumper Locations	B-7
D-1	Subsystem Block Diagram	D-2
D-2	STI Interface Module Block Diagram	D-3
D-3	STI Data Control Block Diagram	D-6

TABLES

1-1	Mechanical & Electrical Characteristics	1-6
3-1	Control Panel Switches and Indicators	3-3
3-2	Operator Corrective Actions	3-11
4-1	Streaming Mode Motion Sequence Chart	4-89
5-1	Removal/Replacement Index	5-5
5-2	Fault Code Matrix (Operator Test 01)	5-74
5-3	TMSCP Fatal Error Codes Deposited Into SA Register	5-90
5-4	TMSCP Status and Event Codes	5-91
5-5	Maximum Error Number	5-97
5-6	Control Commands	5-99
5-7	Operating Commands	5-101
B-1	TU81/TA81 Configuration	B-1
C-1	Related Documents	C-1

PREFACE

This manual contains information pertinent to the operation and maintenance of the TU81 and/or TA81 Tape Subsystem. The subsystem is defined as a tape transport, an I/O interface, and a data bus adapter module.

Related documents are listed in Appendix C of this manual.

Section 1 - GENERAL DESCRIPTION

1.1 GENERAL

The TU81/TA81 Streaming Tape Unit is a microprocessor-based, electronic and mechanical assembly containing all hardware and firmware necessary for the transfer of Phase Encoded (PE) or Group Coded Recording (GCR) data to and from half-inch wide magnetic tape.

The horizontally mounted transport is a fully integrated tape storage system packaged with its power controller in a standard H9643 cabinet.

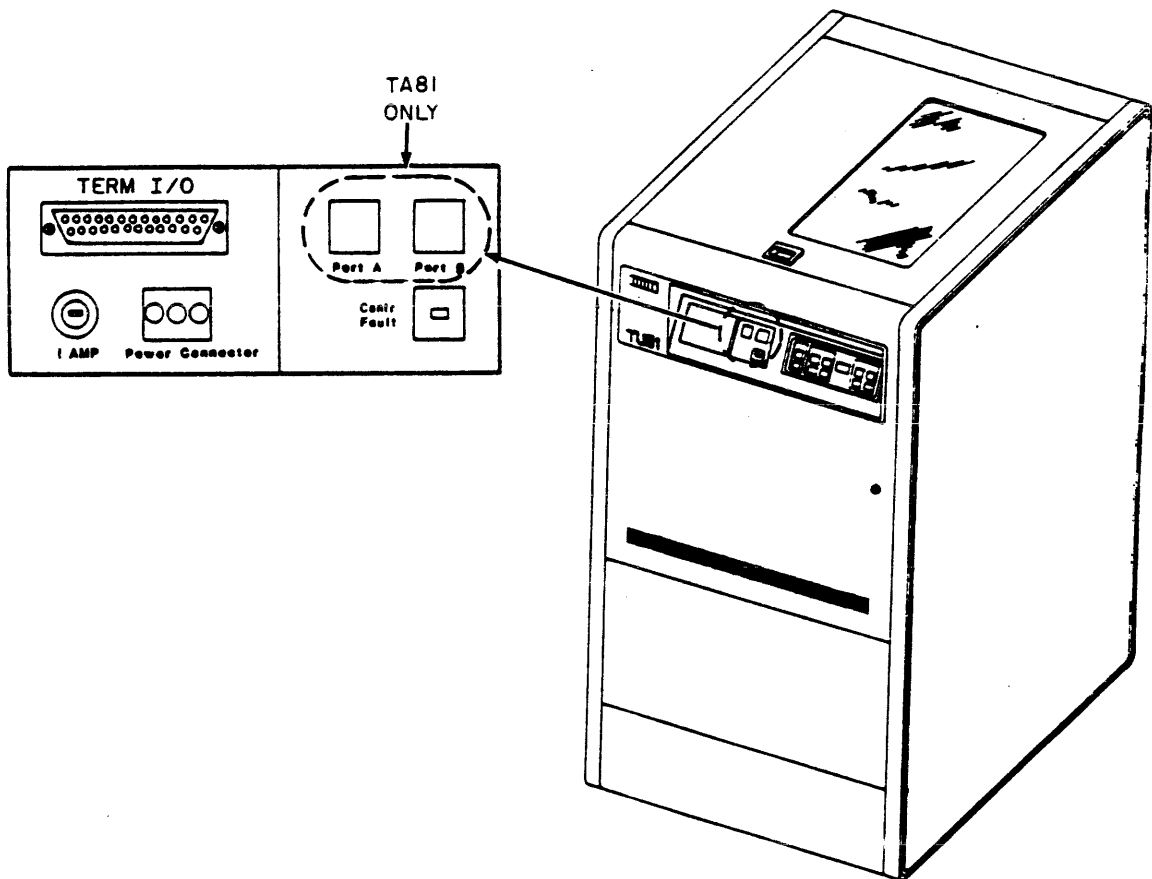

02B01-101

TU81/TA81 TAPE TRANSPORT

Solid-state electronics replace many devices that were traditionally mechanical. Tape moves from reel to reel, maintaining its tension by means of an electronically controlled servo. This non-buffered approach allows performance equivalent to that of a conventional capstan-controlled drive in the start/stop operating mode. The transport contains no capstan motor drive, tension arms, vacuum columns, or associated components. Read/Write functions are accomplished in an ANSI-compatible format at 1600 bits per inch (BPI) Phase Encoding or 6250 BPI Group Coded Recording.

The TU81 subsystem and TA81 subsystem are very similar in layout, operation, and functional capability. The principal difference between the two is in the input/output interface - that is, in the way the subsystem is physically connected to and communicates with its host computer. Both tape subsystems consist of the same stand-alone tape drive, but have a different I/O controller module. These tape subsystems are summarized as follows:

- o The TU81 subsystem consists of the tape drive and UNIBUS interface. The TU81 connects directly to the host through the Low-End Storage Interconnect (LESI) bus and UNIBUS adapter, and uses Tape Mass Storage Control Protocol (TMSCP) to communicate with various DEC components (see Figures 1-1A and 1-2A).

- o The TA81 subsystem consists of the tape drive and Standard Tape Interface (STI) interconnect bus. The TA81 is to be used with the HSCXX Mass Storage I/O Controller. The HSCXX enables multiple processors to access a common pool of disks and tapes. The TA81 has a dual communication port that enables the tape drive to be sequentially shared by at least two HSCXX controllers (see Figures 1-1B and 1-2B).

NOTE

The cabinet may hold an optional disk drive mounted under the tape transport at the bottom of the cabinet. Consult the User Guide of the appropriate disk drive for user information.

The TU81/TA81 subsystem itself includes a tape deck with a read/write head, reel hubs, servo motors, power supply and air bearings. Printed circuit modules contain the following electronic features: servo power amplifier, read/write, reel servo control, data encoding and decoding, and microprocessors with their support devices (for transport control in both the operational and diagnostic modes). The device features a quick-release reel latch which, like its simplified tape threading path, is designed for ease of operation.

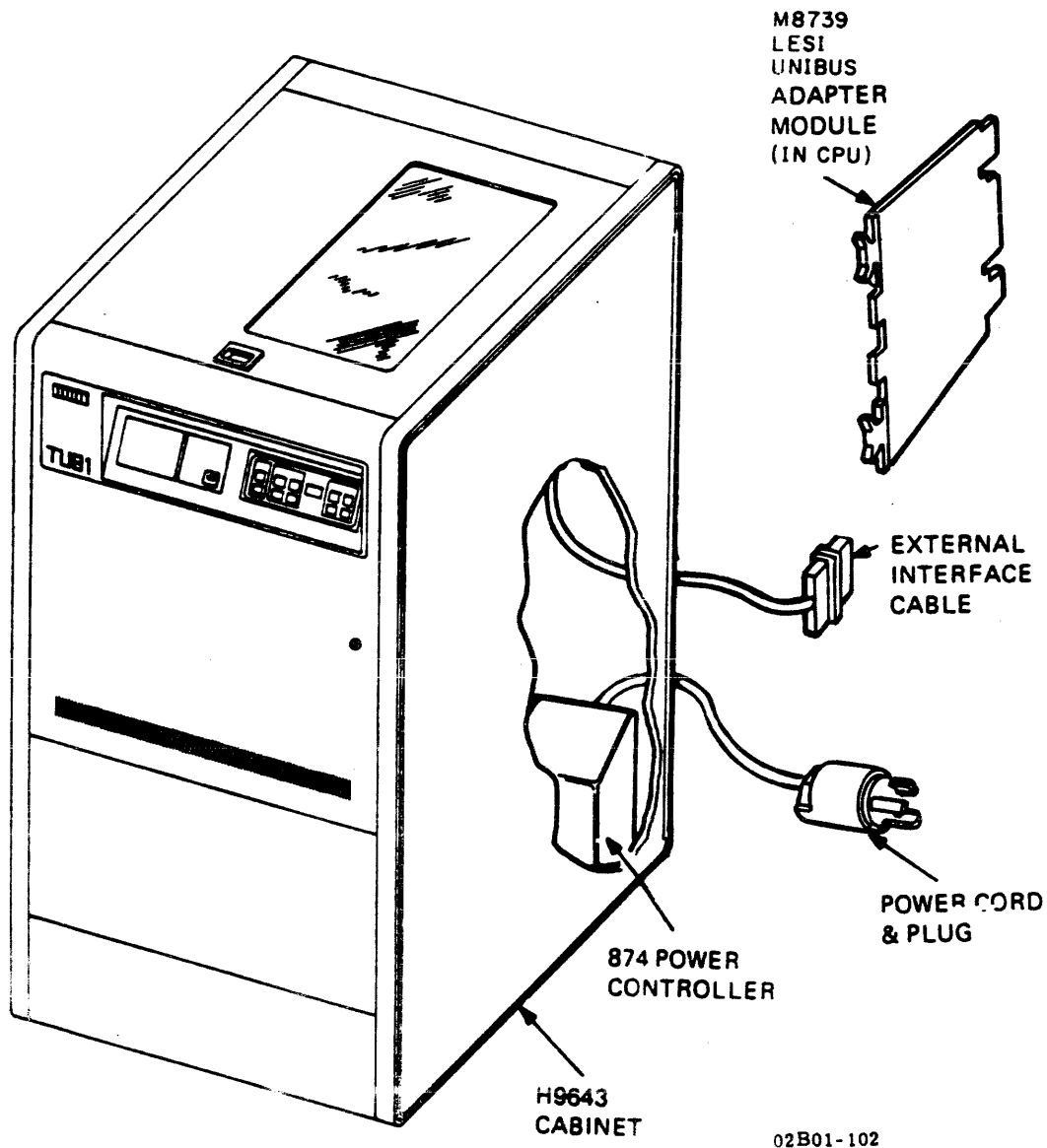
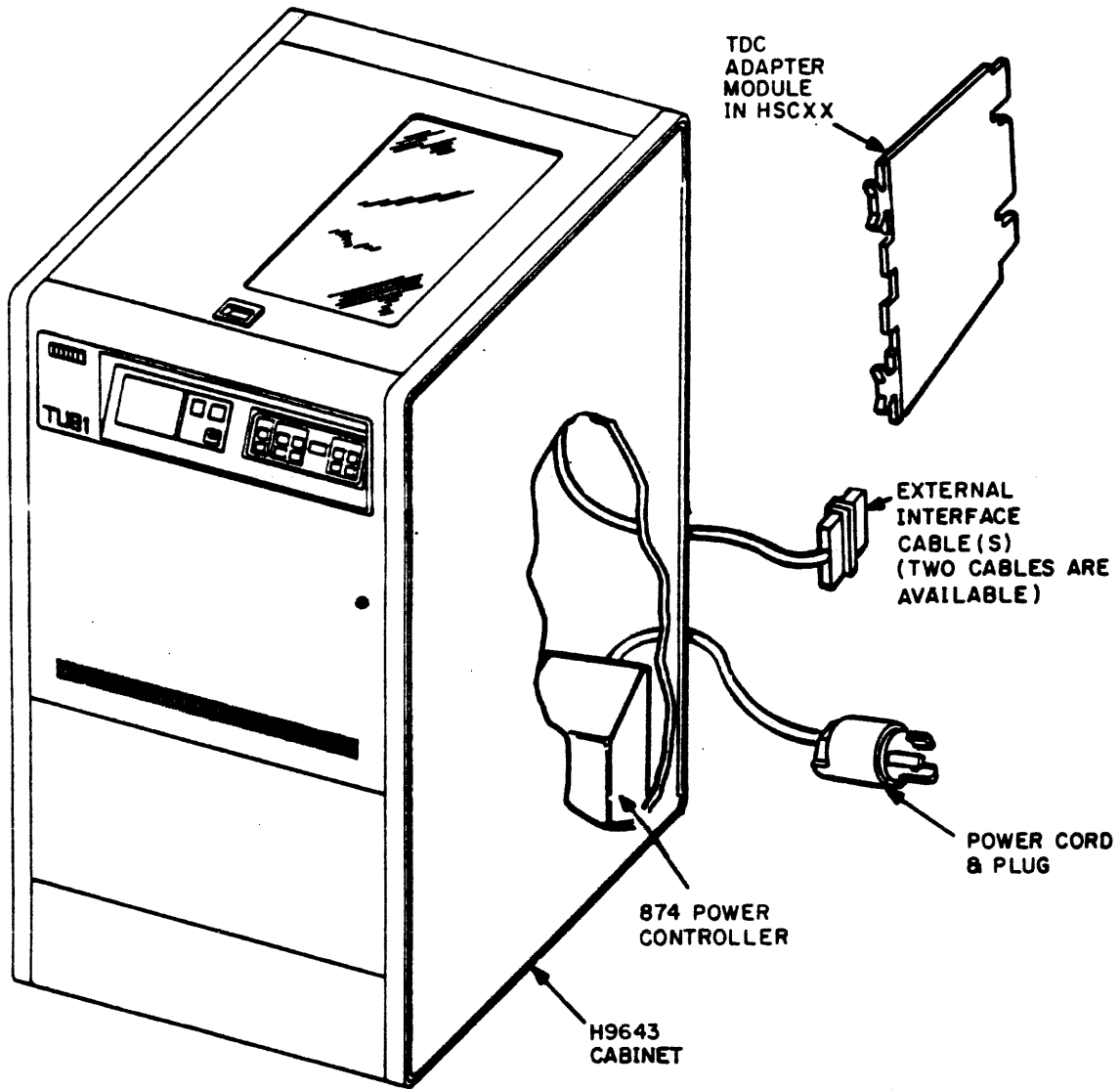
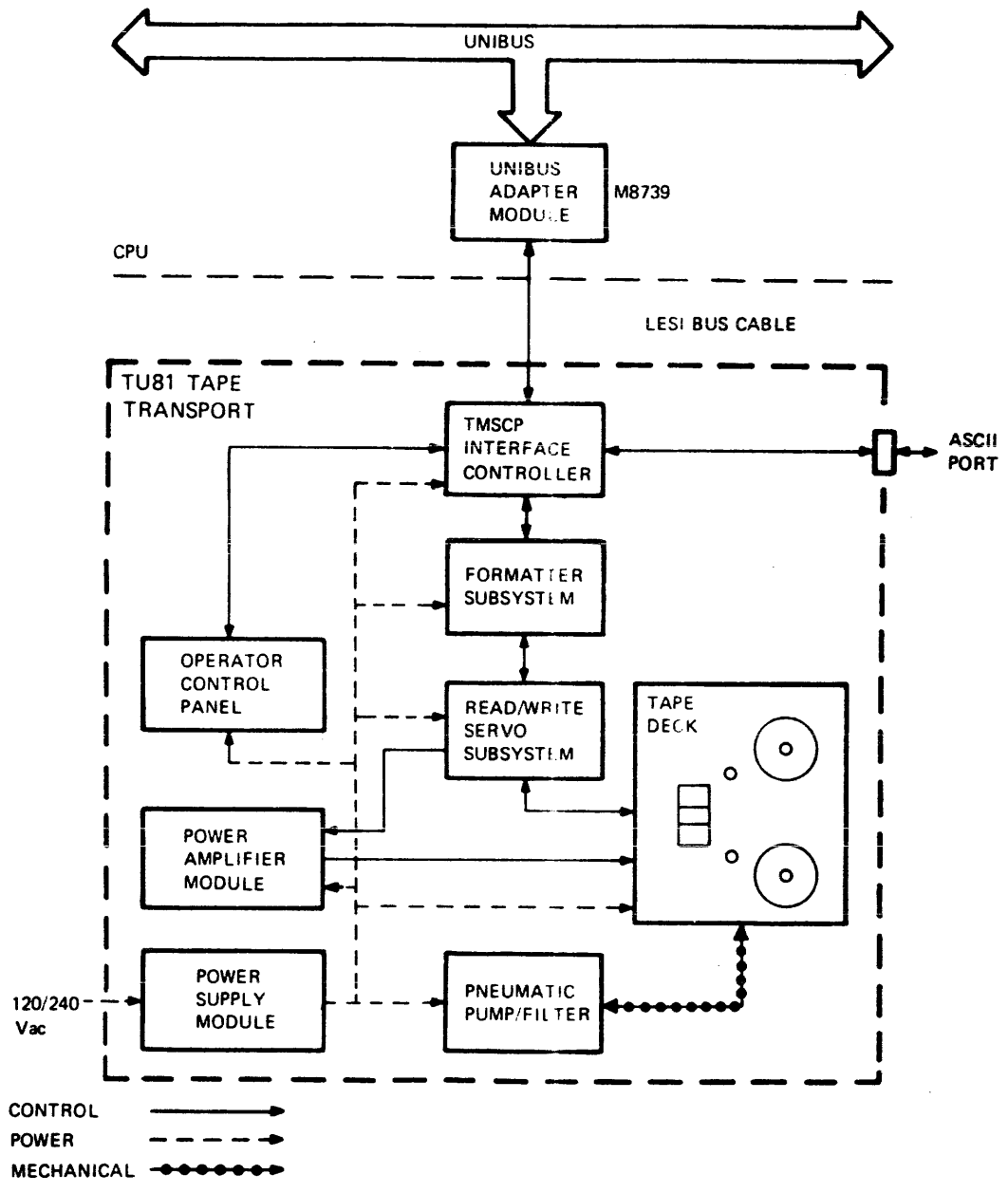

Figure 1-1A. TU81 TAPE SUBSYSTEM



02B01-102

Figure 1-1B. TA81 TAPE SUBSYSTEM



MA-1176-83
 SHR-0447-85

Figure 1-2A. TU81 TAPE SUBSYSTEM BLOCK DIAGRAM

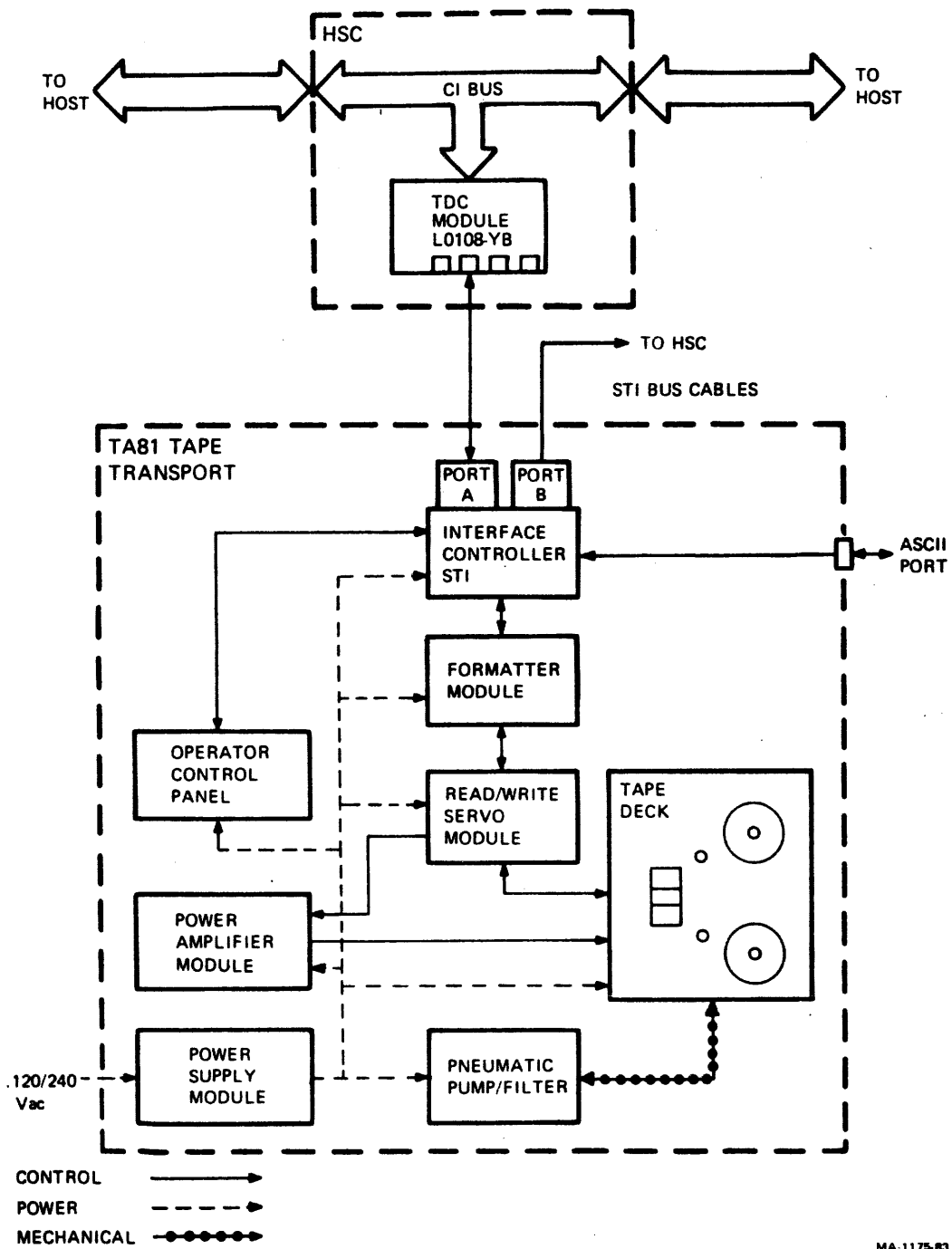

MA-1175-83
SHR-0168-85

Figure 1-2B. TA81 TAPE SUBSYSTEM BLOCK DIAGRAM

Multiple data transfer rate capability is achieved by allowing selection of the 25 ips modes and 75 ips streaming mode and density selection through the adapter interface. The 25 ips modes operate at an instantaneous data rate of 40,000 bytes/second when in PE mode and 156,250 bytes/second when in GCR mode. The 75 ips streaming mode operates at 120,000 bytes/second when in PE mode and 468,750 bytes/second when in GCR mode.

Selection of either a normal Inter-Block Gap (IBG) length of 0.6 inch or a longer IBG length of 1.2 inches when in PE mode, and 0.3 inch or a longer IBG length of 0.6 inch when in GCR mode is also available through the adapter interface. Optionally, long and short gaps can be selected to be variable length.

All transport address and feature selections are required to be verified (and/or set) before TU81/TA81 initialization. These selections are performed through jumpers on the Formatter/Write and Interface Modules as shown in Appendix B of this manual.

Off-line diagnostic routines are designed into the transport and are capable of isolating faults throughout its electronics. These diagnostic routines which are initiated via the operator's control panel, and consist of operator and field service diagnostics, are explained in detail in the TU81/TA81 Subsystem Diagnostic Test Documentation/Pathfinder (EK-TUA81-SV-001).

The host I/O controller is capable of monitoring the transport status through the Status Transfer command. In addition to the off-line routines initiated by the control panel, Power-On Health Check is also an integral part of the transport. The transport automatically performs a "power-on health check" sequence of host routines to check AC/DC power lines and the control panel each time power is applied.

Table 1-1 provides a list of mechanical and electrical characteristics for the TU81/TA81 transports.

On-line diagnostics are performed under the host CPU control and are listed in the applicable system's diagnostic listings.

NOTE

Appendix C provides the listing of the TU81/TA81 documents available to user.

Table 1-1. MECHANICAL & ELECTRICAL CHARACTERISTICS

FUNCTIONAL CHARACTERISTICS:

Tape Speed (Nominal)	
a. Low Speed Start/Stop Mode	25 in/sec
b. Low Speed Streaming Mode	25 in/sec
c. High Speed Streaming Mode	75 in/sec
Data Format/Recording	
a. GCR	6250 BPI, 9-track
b. PE	1600 BPI, 9-track
Data Transfer Rate	
a. GCR	
1. High Speed	469 Kbyte/sec
2. Low Speed	156 Kbyte/sec
b. PE	
1. High Speed	120 Kbyte/sec
2. Low Speed	40 Kbyte/sec
Rewind Time (Nominal)	2.5 minutes (2400 foot reel)
Load Time (Maximum)	15 seconds

PHYSICAL CHARACTERISTICS:

Electronics	Solid-state
Tape Width	12.65 mm (0.5 in)
Tape Thickness	38.1 micron (1.5 mil)
Tape Tension	2.23 N (8.0 oz)
Reel Diameter	26.7 cm (10.5 in) *
Reel Capacity	732 m (2400 ft) *
Transport Dimensions	105.7 cm (H) x 54.6 cm (W) x 76.2 cm (D) 41.6 in (H) x 21.5 in (W) x 30.0 in (D)
Transport Weight (In Cabinet)	139 kg (295 lbs)
UNIBUS Adapter (TU81 Only)	Standard quad-size module +5V at 4A maximum

* Smaller tape reels are also allowed.

Table 1-1. MECHANICAL & ELECTRICAL CHARACTERISTICS (Cont'd)

OPERATIONAL CHARACTERISTICS:

Power Requirements	
a. Current	Average Input Current 3.2A rms at 75 ips streaming
b. Voltage	93 to 128 VAC, 120 VAC nominal, 60 Hz, single phase 187 to 256 VAC, 220 or 240 VAC nominal, 50 Hz, single phase
c. Power Consumption	300 VA - Standby and Loaded 550 VA maximum - Start/Stop
d. Power Controller	Model 874B, 50 Hz, 240V, 12A Model 874D, 60 Hz, 120V, 24A
e. Power Cord (For 120V, 60 Hz)	3-wire, #12 AWG, 14 feet long plug - NEMA L5-30P, Hubbel 2611
Model Variations	Model TU81-CA, 120V, 60 Hz Model TU81-CB, 240V, 50 Hz Model TA81-CA, 120V, 60 Hz Model TA81-CB, 240V, 50 Hz
Operating Temperature **	15°C (60°F) to 33°C (90°F)
Storage Temperature	-10°C (14°F) to 50°C (122°F)
Relative Humidity	20% to 80% (10% to 90% in storage)
Altitude	Up to 3048 m (10,000 ft) or 688 millibars (9.98 psi)
Heat Dissipation (Average)	1100 BTU/hour
Acoustical Noise	6.8 bels (max.) in operating mode
Data Reliability	
a. Recoverable Write Error	1 in 10 ⁸ bits
b. Recoverable Read Forward Error	1 in 10 ⁹ bits
c. Recoverable Read Reverse Error	1 in 10 ⁸ bits
d. Unrecoverable Read Error	1 in 10 ¹⁰ bits (PE), 1 in 10 ¹¹ bits (GCR)
e. Unrecoverable Write Error	Not Allowed

** Restricted by the operating temperature of the media.

1.2 FUNCTIONAL DESCRIPTION

Functionally, the TU81/TA81 comprise the transport control system, the power supply, and the tape drive unit which is similar for both TU81 and TA81, and one interface (which is unique in both subsystems).

1.2.1 Transport Control System

The transport control system consists of two logic/control subsystems and a power amplifier module. All logic modules are functionally partitioned and controlled by the on-board microprocessors.

The Formatter Read/Formatter Write subsystem comprising two logic modules is used to control the drive operation and to convert the received I/O commands into the motion and data transfer operations of the tape drive. Data received from the host via the interface controller module is converted by the formatter to GCR or PE format and is passed on to the read/write head to be recorded on tape. Data read from tape is "on-the-fly" error corrected, converted into data bits, and passed via the interface to the host. The formatter also stores and monitors the built-in diagnostic routines.

The Read Amplifier/Write Driver/Servo-Control subsystem consists of three logic modules whose function is to increase the level of read/write signals and to control electromechanical functions of the tape drive (reel motors, tension sensors, magnetic head, etc.)

The power amplifier module receives low voltage analog control signals from the Read Amplifier/Write Driver/Servo-Control subsystem and outputs higher voltages to the reel motors.

1.2.2 Interface System

The interface system consists of the resident (transport-mounted) interface controller module, interface bus, and a communication interface adapter module installed in an appropriate system control unit. The TU81 and TA81 employ different interfaces, as follows:

1.2.2.1 TU81 Interface - The TU81 tape transport is directly interfaced to the host Central Processing Unit (CPU) (See Figure 1-2A). The interface consists of a transport-mounted TMSCP interface controller module, LESI bus to the CPU, and a UNIBUS/LESI adapter module plugged into a Small Peripheral Controller (SPC) slot in the host I/O backplane.

NOTE

Paragraphs 4.9 and 4.10 and Appendix A give more detailed information on the TU81 Interface.

The UNIBUS/LESI adapter module (M8739) is the standard quad-size PC card that provides physical interface with the CPU's I/O. It supervises several I/O functions and works with the resident TMSCP I/O controller in command and data transfers. The Physical LESI interconnect between the CPU and TU81 comprise three 50-conductor cables. The external round-shielded cable is 20 feet long. The interconnect also includes internal ribbon cable in the CPU (from the M8739) and in the TU81 (from the TMSCP controller).

The TU81 uses the asynchronous TMSCP data communication protocol to transmit data. This enables the TU81 to communicate with various DIGITAL computer systems.

The TMSCP resident interface module is a complete on-board interface controller that establishes data interface between the LESI bus and PE/GCR formatter. This module is mounted in the same logic cage as the formatters. The microprocessor-based controller fetches and translates host-originated command messages into PE/GCR formatter commands. It monitors and encodes formatter and drive status data into the status messages and transmits them to the host. It also supervises bi-directional data transfer between the host CPU and TU81.

1.2.2.2 TA81 Interface - The TA81 can be connected to the host systems only through the HSCXX I/O controller. The TA81 communicates with the HSCXX by means of the STI interface which consists of the transport-mounted STI interface controller module with two I/O ports, one or two flat STI bus cables, and the HSCXX-mounted Tape Data Channel (TDC) module (L0108-YB). Data transfers on the STI bus are performed according to the STI protocol. Dual communication port enables sequential access from at least two host systems under control of the HSCXXs. Maximum availability is achieved by connecting one TA81 to two HSCXX controllers (see Figure 1-2B).

NOTE

The STI interface controller and TDC module functions are similar to that of the corresponding TU81 modules (see above) except for the different (STI vs TMSCP) communication bus and protocol. Appendix D gives more detailed information on the TA81 interface.

The transport logic and interface modules are compactly mounted in two metal cages under the tape deck.

1.2.3 Power Supply

The power supply is vertically mounted in the rear of the tape deck and provides all required ac/dc voltages. The switched 120 or 240 volts to the power supply come from the 874 power controller located at the bottom of the transport cabinet.

1.2.4 The 874 power controller is connected to the CPU or HSCXX by the power switching line which enables the CPU (or HSCXX) to remotely control ac power ON/OFF to the on-line tape transport.

NOTE

Refer to Appendix A for detailed information on the M8739 UNIBUS Adapter.

1.3 PHYSICAL DESCRIPTION

The TU81/TA81 is a cabinet-enclosed, horizontally mounted unit designed to provide front access for both operator and maintenance functions. Operator access for tape mounting is via the hinged top cover. Maintenance access to the underside of the tape deck is achieved by opening the top cover and front door and releasing the deck latch located at the left underside of the tape deck. Releasing this latch allows the tape deck to pivot such that the underside of the deck is positioned to the front of the cabinet in a vertical position.

The input power cord and interface cables enter the cabinet at the rear bottom of the unit. Access to this area is via a hinged rear door.

1.3.1 Tape Deck - Top

Refer to Figure 1-3 for component locations. The following components are located on the front of the transport. A brief description of the components and their function is provided as follows.

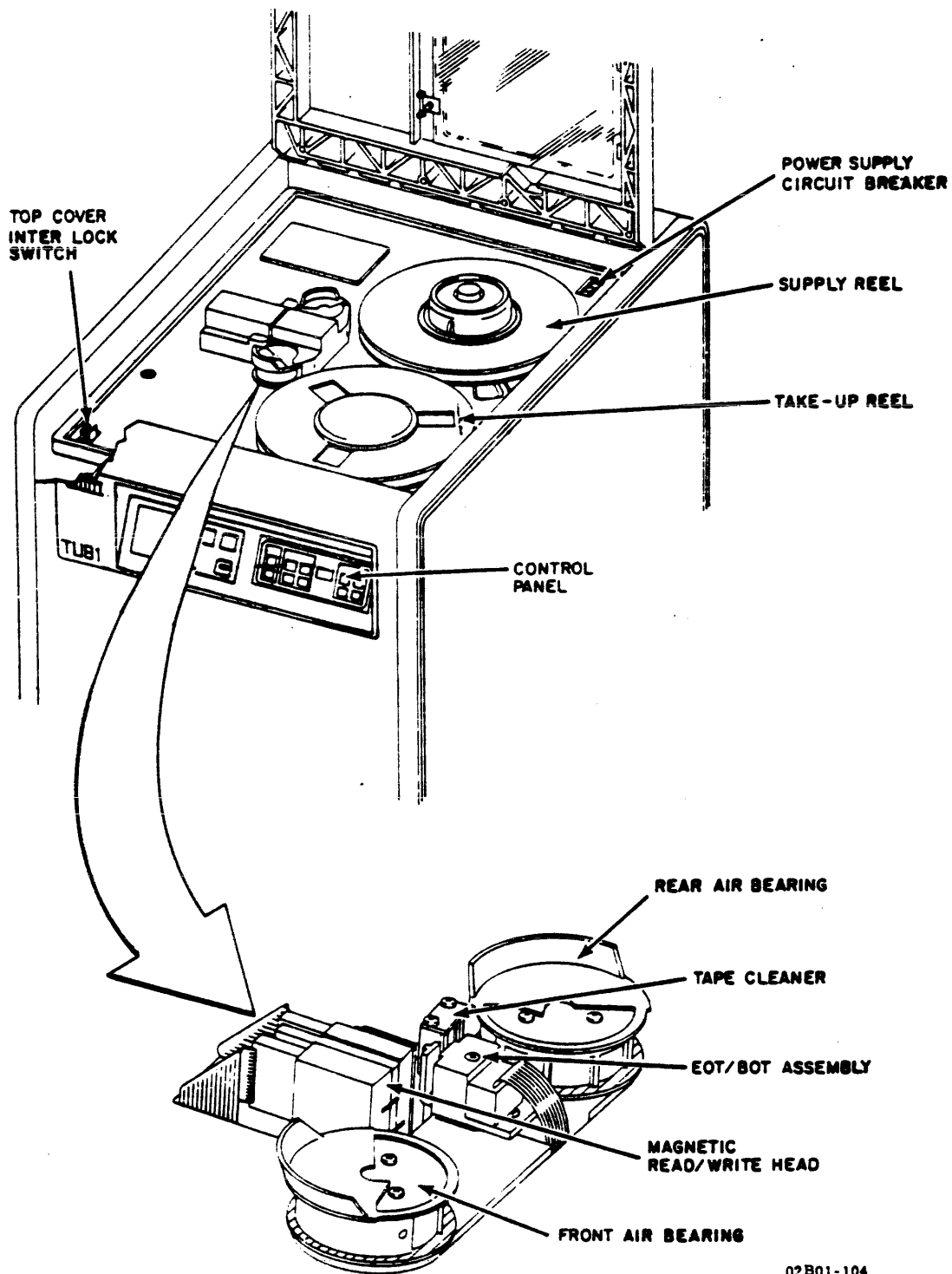

02B01-104

Figure 1-3. COMPONENT LOCATION - TOP VIEW

1.3.1.1 Supply Reel - The supply (rear) reel is mounted on a manual mechanical-latching hub. The supply hub is latched by pressing the periphery of the hub face while the supply reel is positioned against the bottom flange of the hub. The reel is released by pressing the center button on the hub face.

1.3.1.2 Take-Up Reel - The take-up (front) reel is a permanently mounted reel secured to the take-up motor shaft.

1.3.1.3 Air Bearings - The air bearing/tension sensor assembly is used to sense and control air pressure across the air bearings, thus reducing tape friction and providing constant (8 ounce) tape tension by the corresponding action of the supply reel motor. The air bearings also guide tape across the magnetic heads.

1.3.1.4 Magnetic Head Assembly - The magnetic head is a dual-gap read/write unit designed to perform the read/write functions in a 9-track PE or GCR mode. The dual-gap head allows a write-to-tape operation, read-only operation, or read-after-write operation. A full-width erase head is also provided to erase the tape by DC saturation in the forward direction before passing over the write head.

1.3.1.5 Tape Cleaner - The tape cleaner assembly consists of two blades and a vacuum port to attract tape to the cleaner surfaces. The cleaners are designed so that one cleaner cleans tape in the forward direction and the second cleans tape in reverse direction. The vacuum system directs the stripped particles through a screen and into a filter.

1.3.1.6 BOT/EOT Assembly - Load Point/End of Tape is detected optically. Photo-transistors detect light reflected from BOT and EOT markers on tape. A no-tape-present condition is detected when both BOT and EOT photo-transistors detect a reflective marker normally blocked by the presence of tape.

1.3.1.7 File Protect - The file protect assembly consists of a 360° reflecting ring around the supply hub and a photo-transistor mounted adjacent to the reflecting ring. If a write enable ring is installed in the supply reel, the reflecting ring is in direct line with the photo-transistor. If a write enable ring is not present, then the reflecting ring is out of the path of the photo-transistor.

1.3.1.8 Power Supply Circuit Breaker - The power supply circuit breaker is located at the right rear corner of the tape deck. In the OFF position (0 side pressed), input ac voltage is removed from the power supply. The host controls the ON-OFF state of the input power to the transport by means of a power switching cable. Therefore, during normal use, the power supply circuit breaker should be in the ON position (1 side pressed).

1.3.1.9 Top Cover Interlock - The transport is equipped with an interlock switch/top cover latch located at the lower left corner of the tape deck. This interlock is basically a safety device to prevent reel motion, unless the front cover is closed and secured.

1.3.2 Tape Deck - Bottom

Refer to Figure 1-4 for component locations. The following components are located on the bottom of the tape deck. A brief description of the components and their function is provided as follows.

1.3.2.1 Tape Deck Latch - This latch enables the tape deck to be placed in the maintenance position for access to the bottom tape deck assemblies.

1.3.2.2 Power Supply - The power supply accepts the input AC voltage from the 874 Power Controller and converts it to six (+5, -6, +15, -15, +25, +38) DC output voltages. The supply contains a line filter, unit circuit protectors, on/off circuit breaker, logic master clear circuit, cooling blower control, pneumatic pump motor control, and voltage and current monitors.

1.3.2.3 Pneumatic Pump and Filter/Regulator System - The pneumatic pump is a 120V (60 HZ) or 220/240V (50 HZ) AC inductor motor with a 4-blade, carbon vane pump. The compressor output air is routed to a filter where any carbon particles are removed before distribution to tape deck components. Mounted directly onto the filter is a piston-type pressure regulator which maintains a constant 2.0 PSI output to the upper and lower air bearings. The vacuum portion of the pump draws air from the tape cleaner.

If the TU81/TA81 does not receive a new command from the host within one minute, transport automatically shuts down the pneumatic pump (compressor) and removes power from the reel motors. If the transport has entered the shut-down mode, execution of the first command received from the host is delayed by approximately one second.

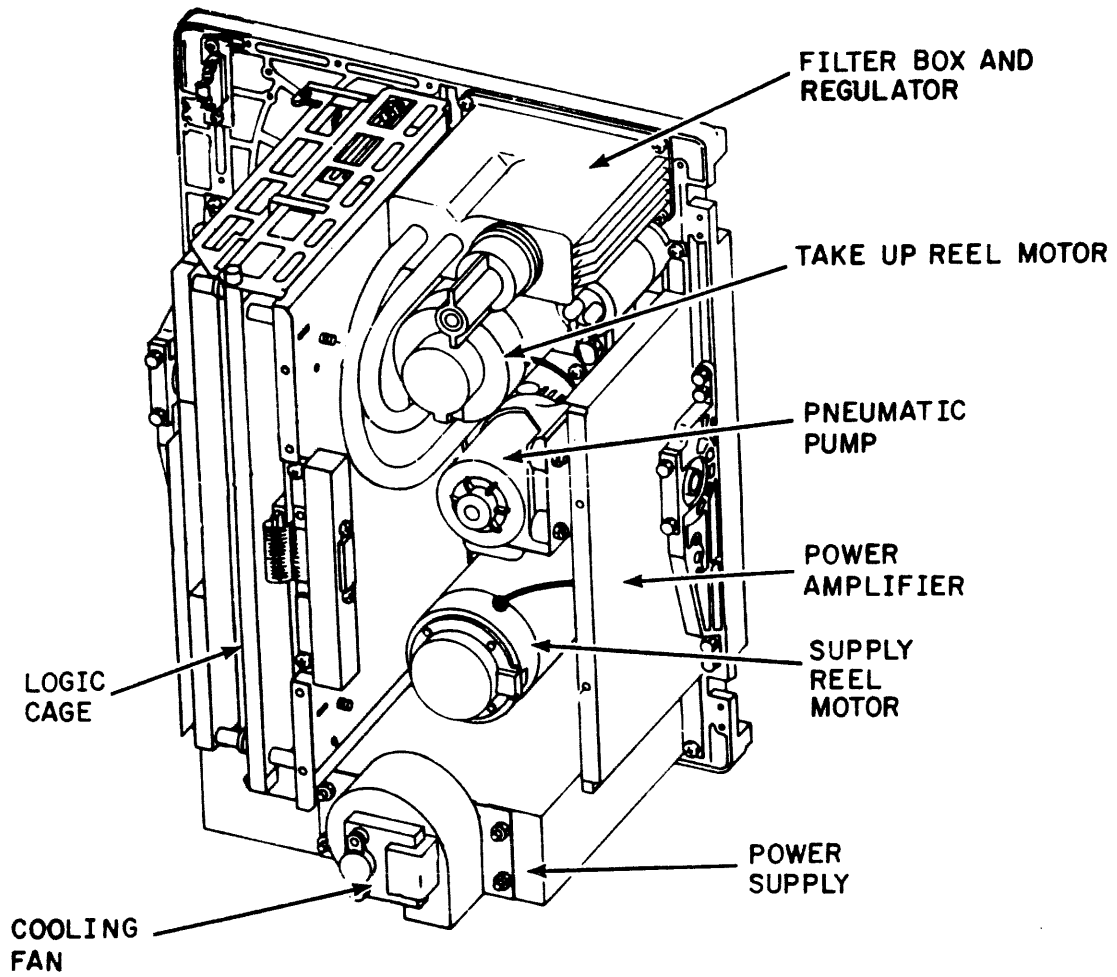

02B01-105

Figure 1-4. TAPE DECK COMPONENT LOCATIONS - REAR VIEW
(DRIVE COVER REMOVED)

1.3.2.4 Power Amplifier Module - The power amplifier module receives the low voltage analog signals from the control logic and outputs a higher voltage, high current to the reel motors. Outputs are dependent on the requirements of the velocity and tension servo systems.

1.3.2.5 Cooling Fan Assembly - The cooling fan is a squirrel-cage type assembly located at the rear of the power supply. Cooling air is drawn across the rear deck assemblies and through the power supply. The fan motor is compatible with either 120 or 240 volt operation.

1.3.2.6 Logic Cages - These two metal cages, mounted vertically under the tape deck, serve as the mounting and security enclosures for the six logic modules. One cage holds the Formatter Read module, the Formatter Write module, and the Interface Controller module. The external I/O cable(s) plug into connector(s) on the cage mounting plate. The other logic cage holds the Read Amplifier module, the Write Driver module, and the Servo-Control module. The modules are inserted into top and bottom hinges at the rear of the bracket assembly and are secured with thumb screws in the normally closed position. Releasing the thumb screws allows the hinged modules to be positioned for access to components.

1.3.2.7 Reel Motors - The reel motors are conventional, permanent-magnet DC motors. The supply reel motor works in conjunction with the upper and lower air bearings to control tape tension across the recording surface of the magnetic head. The air bearings sense the proximity of tape via air pressure and, in effect, activate the pressure sensors. The sensors cause the servo to maintain a constant tension by action of the supply reel motor. The take-up reel motor has a 1000-segment tachometer attached which provides velocity control.

1.3.3 Control Panel (Front Door)

The control panel includes a set of operational control switches, indicators, and a display located at the top right of the front door. These controls enable the operator to initiate and monitor on-line operations and the off-line diagnostic routines.

1.4 EQUIPMENT CONFIGURATION

The equipment configuration of the transport is determined by the equipment identification plate. A description of the ID plate is given in the following paragraphs.

1.4.1 Equipment ID Plate/Serial Tag

The ID plate/serial tag is located on the inside of the hinged front door. Refer to Figure 1-5 for the following items contained on the plate.

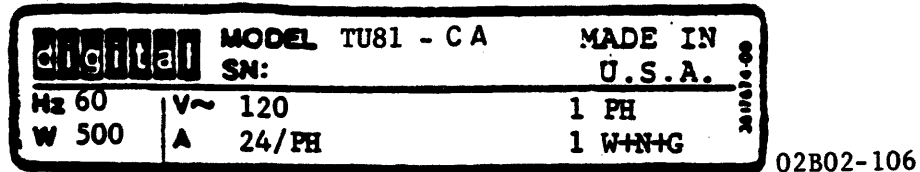

Figure 1-5. EQUIPMENT IDENTIFICATION PLATE

- MODEL - Indicates the model designation and model variation for the unit.
- SN - Indicates the serial number which is unique for each transport and is assigned sequentially by the manufacturer.
- HZ - Indicates the frequency parameters (cycles per second) of the input voltage.
- W - Indicates the total operating power consumption of the transport.
- V - Indicates the input voltage requirement of the transport.
- A/Ph - Indicates the maximum ampere requirement per phase.
- Ph - Indicates the phase requirement of the transport.
- W+N+G - Indicates the configuration of the input power line cord (active wire + neutral + ground).

Section 2 - INSTALLATION AND CHECKOUT

For installation and checkout procedures, refer to the following publications:

- o TU81/TA81 Tape Subsystem User Guide EK-TUA91-UG
- o TU81 Magnetic Tape Subsystem Pocket Service Guide EK-OTU81-PS
- o TA81 Magnetic Tape Subsystem Maintenance Guide AA-Z786A-TC

Section 3 - OPERATION

3.1 GENERAL

This section contains a description of the TU81/TA81 control panel and instructions on tape loading and unloading procedures. Also supplied in this section are operator corrective action procedures in response to fault codes displayed on the control panel.

3.2 CONTROL PANEL

As can be seen in Figures 3-1 and 3-2, the control panels of the TU81 and TA81 are almost identical, the difference being the addition of communication switches A and B on the TA81. All panel switches are of pushbutton type. Switch functions and the conditions required for enabling the functions are given in Table 3-1. Figure 3-3 shows the general view of the TU81/TA81 control panel.

The central part of the control panel (OPERATOR) contains operator-oriented switches and indicators (Figure 3-3). The 3-digit display shows the unit number during the normal operation. If an error occurs, either during on-line operation or off-line diagnostic routine, the display will indicate the 3-character error code (e.g., E31). While running the off-line resident diagnostic, the display shows the number of the test in progress.

The right part of the panel (MAINTENANCE) contains the switches and lights for running the resident diagnostic test routines.

The left part of the control panel (SPECIAL) provides special-purpose switches, connectors, and indicators. These are the FAULT/CONTROLLER switch/indicator, the Field Service-used ASCII Test Panel, and the communication channel selection switches Port A and Port B (TA81 only).

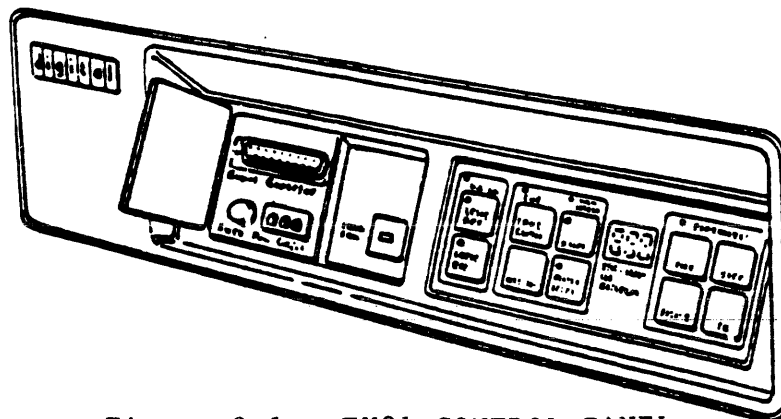
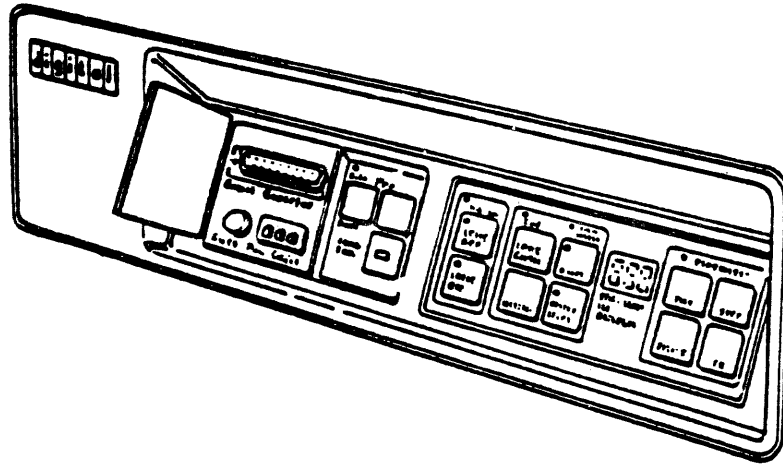

Figure 3-1. TU81 CONTROL PANEL

MA-1166A-83



MA-1164-83

Figure 3-2. TA81 CONTROL PANEL

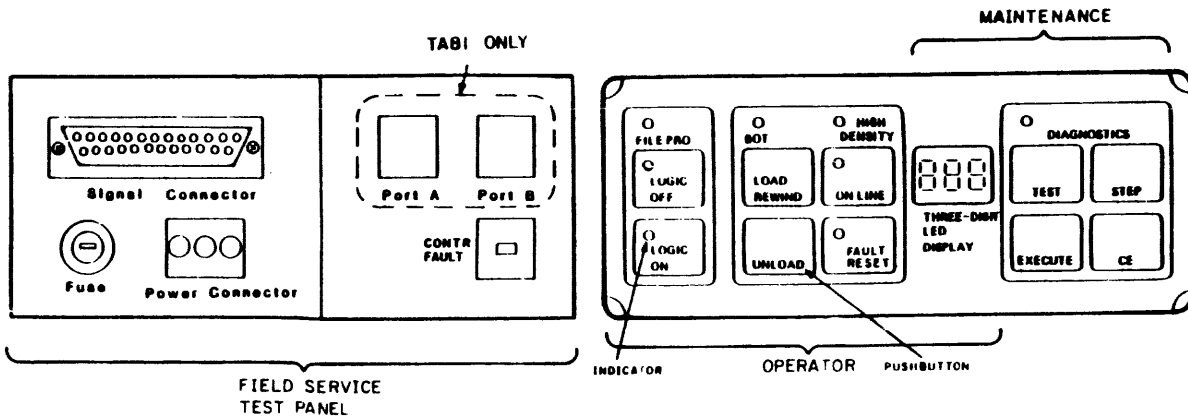

Figure 3-3. CONTROL PANEL FUNCTIONS

Table 3-1. CONTROL PANEL SWITCHES AND INDICATORS

SWITCH/INDICATOR	FUNCTION
<u>Operator Controls</u>	
LOGIC OFF	Indicator - When lit, LOGIC OFF indicates a Power Fault condition, meaning that there is a failure in the transport power supply operation.
LOGIC ON	Indicator - When lit, LOGIC ON indicates a normal Power-On condition with all dc voltages applied to the transport's control system and circuits. <u>NOTE:</u> LOGIC OFF and LOGIC ON are indicators only, not operational switches.
BOT	Indicator - When lit, indicates tape is positioned at beginning-of-tape (BOT) marker.
LOAD/REWIND	Switch - If transport is powered on and tape is threaded, pressing this switch causes a load operation to be performed. If tape is loaded, pressing the switch causes a rewind operation to BOT.
UNLOAD	Switch - If tape is loaded at BOT, pressing this switch causes tape to unload from take-up reel and tape path onto supply reel. If the tape is loaded beyond BOT, it rewinds to BOT. If tape is threaded, but not loaded, pressing the switch causes the transport to slowly unload tape onto the supply reel.
ON-LINE	Switch - If tape is loaded, pressing this switch causes transport to go on-line and become accessible by the host system. Press RESET switch to take transport off-line. Indicator - When lit, indicates that TU81/TA81 is in on-line mode. All switches except RESET are inhibited.
FILE PRO	Indicator - When lit, indicates absence of a write enable ring in supply reel and a write operation is inhibited. Otherwise, write operations are allowed.

Table 3-1. CONTROL PANEL SWITCHES AND INDICATORS (Cont'd)

<u>SWITCH/INDICATOR</u>	<u>FUNCTION</u>
<u>Operator Controls (Cont'd)</u>	
HIGH DENSITY	Indicator - When lit, indicates that the transport is selected by the host system for GCR operation.
RESET	Switch - When pressed, this switch places transport off-line, stops tape motion, and clears error status. The switch can stop a load or rewind operation. It also turns off RESET indicator and clears diagnostic test conditions.
FAULT/RESET	Indicator - When lit, indicates that transport is in a fault or diagnostic status. A 3-digit display may contain a fault or diagnostic code.
<u>Maintenance Controls</u>	
DIAGNOSTIC	Indicator - When lit, indicates that transport is in diagnostic/test mode. The indicator remains on until RESET switch is pressed.
TEST	Switch - If tape is threaded, but not loaded, pressing this switch places unit in diagnostic/test mode.
STEP	Switch - In the diagnostic/test mode, pressing this switch causes diagnostic/ test sequence numbers in 3-digit display to be incremented to digit required.
EXECUTE	Switch - If transport is in diagnostic/test mode (and test number is displayed), pressing this switch initiates internal diagnostic test shown on 3-digit display.
CE	Switch - If transport is in diagnostic/test mode, this switch helps to recall and run Field Service Diagnostics.

Table 3-1. CONTROL PANEL SWITCHES AND INDICATORS (Cont'd)

SWITCH/INDICATOR	FUNCTION
<u>Special Controls</u>	
In the TU81 Subsystem:	
CONTR FAULT	<p>Indicator - When lit, indicates the TMSCP Interface Controller FAULT condition until it is cleared by the TU81 or host.</p> <p>Switch - With CONTR FAULT on, pressing this switch causes TU81 transport to attempt to clear the fault condition. If fault is corrected (either through the transport or host), CONTR FAULT goes off and the TU81 is available to the host again.</p>
In the TA81 Subsystem:	
CONTR FAULT	<p>Indicator - When lit, indicates the STI Interface Controller FAULT condition until it is cleared by the TA81 or HSCXX.</p> <p>Switch - With CONTR FAULT lit, the STI Controller remains in the same connection state relative to HSCXX. When CONTR FAULT is pressed the first time, TA81 causes transmission to HSCXX. When CONTR FAULT is pressed a second time, the STI Controller attempts to clear the ERROR condition.</p> <p>If this attempt is successful, CONTR FAULT goes off and the transport is available to the HSCXX again.</p> <p>If the STI Controller is unable to clear the ERROR condition, CONTR FAULT remains lit and the transport becomes unavailable to HSCXX for system-generated diagnostics and failure correction.</p>
<p>NOTE: When the interface controller fails (CONTR FAULT is lit), there is no error code displayed in the 3-digit display. The display continues to show unit number.</p>	

Table 3-1. CONTROL PANEL SWITCHES AND INDICATORS (Cont'd)

SWITCH/INDICATOR	FUNCTION
Port A Port B	<u>TA81 Only</u> - Pressing either of the switches causes selection of corresponding interface channel to I/O controller (and host). Indicator shows the active (selected) port.

CAUTION

Complete dual-port functionality is not currently supported under VMS. If, however, both ports are cabled, only one port switch should be enabled at a time.

Port Switch Operation

Through two I/O ports, the TA81 connects to the HSCXX Controllers which are used to control mass storage subsystems of several computer systems. The I/O port becomes operational when the transport is on-line, and the I/O channel is selected through the corresponding port switch. If this switch is disabled with the transport on-line, the transport cannot be disconnected from the I/O port until ONLINE is also disabled.

ASCII Port Test Panel

This panel contains the connectors for an ASCII terminal that are used to run the wide spectrum of general and unique diagnostic tests.

Operator Hints

1. When LOGIC ON indicator is on, all control panel switches and indicators are functional except LOGIC OFF indicator.
2. The ON-LINE switch can be pressed while tape is loading. The TU81/TA81 goes on-line immediately when loaded.
3. When FAULT indicator is on, the control panel is not operable except for RESET switch. To turn indicator off, press RESET switch.
4. Tape unloading is performed at low speed. If there is a lot of tape on take-up reel and you wish to do it more quickly, press LOAD/REWIND first and then UNLOAD.
5. HIGH DENSITY indicator lights when GCR information is being processed.

3.3 OPERATING PROCEDURE

The operating procedure includes preparing and loading the tape reel, powering on the transport, placing it on-line to the host computer, and checking its operational status. If a fault code appears on the 3-digit display during loading or routine operation, refer to Table 3-2, Operator Corrective Actions.

3.3.1 Inserting Write Enable Ring

Before mounting the reel of tape onto the supply hub, determine whether or not the tape is to be recorded (write operation performed). If write operations are to be performed, place a write enable ring into the bottom recessed part of the reel (Figure 3-4). When the reel is prepared, proceed with tape threading and loading.

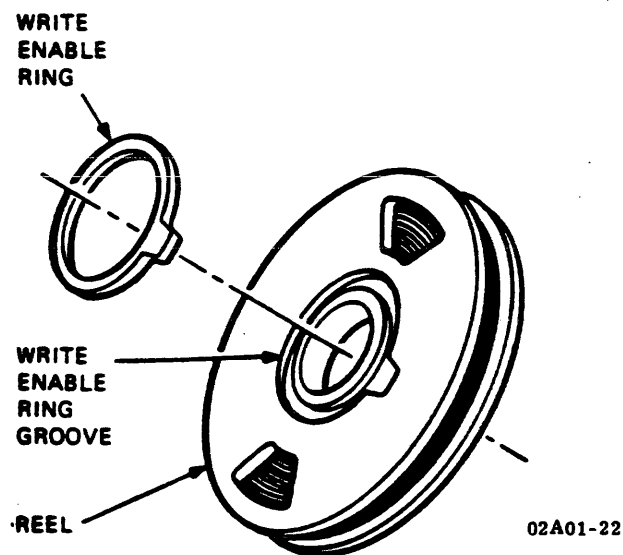

Figure 3-4. WRITE ENABLE RING

3.3.2 Tape Threading and Loading

1. Pull the cover latch toward the front and lift the top access door. Check that the POWER switch is in the ON position (1 pressed).

NOTES

- a. Keep the circuit breaker on 874 Power Controller is ON position all the time.
 - b. The Power switch can also be in ON position all the time to enable the TU81/TA81 transport to be remotely controlled by the CPU, provided the power controller is in REMOTE mode.
2. If necessary, set the Power switch to ON position. If all dc voltages are present, the LOGIC ON and FILE PROT indicators must be lit.

NOTE

If at power-up (or later) the power supply fails, the LOGIC OFF indicator lights and there may be a fault code on the display.

3. Press the inner button on the face of the supply reel hub.
4. Mount the supply reel onto the hub so that the reel is seated on the bottom flange. Secure the reel by pressing the periphery of the hub face to latch the reel.
5. Thread magnetic tape through the tape path as shown in Figure 3-5.
6. Wrap the tape leader (a length of tape before the BOT marker) onto the take-up reel for several turns.

CAUTION

Make sure that the tape is positioned correctly over all tape path components; otherwise, tape damage may occur.

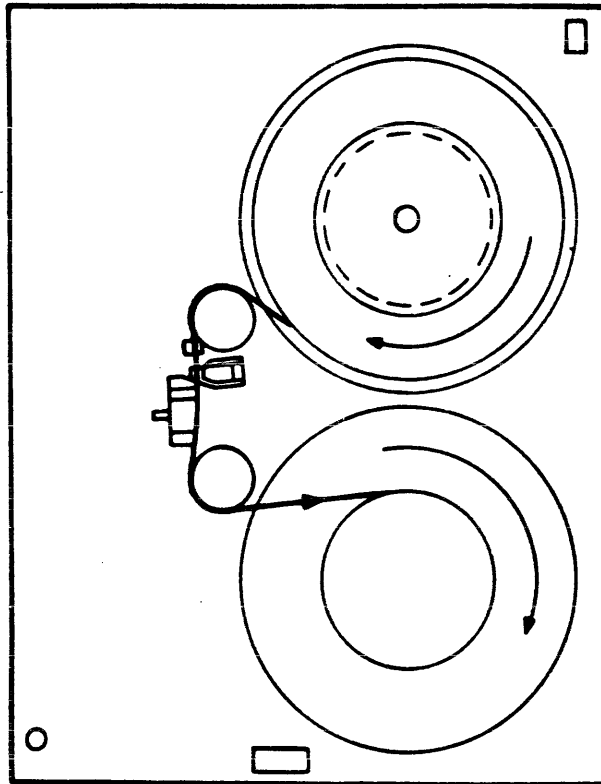

MA-0085-02
02A01-23

Figure 3-5. TAPE PATH

7. Close and latch the top cover.
8. Press the LOAD/REWIND switch. In one second, air pressure builds at the air bearings and tape starts moving in the forward direction. This motion stops when the BOT marker on tape is detected. If the tape was over-threaded and the BOT marker was positioned after the sensor, forward tape motion continues for approximately 40 feet. Then the transport initiates reverse tape motion until the BOT marker is detected. At this moment, tape motion stops and the BOT indicator is lit.

NOTE

If LOAD fails and tape does not move to BOT, check for the BOT marker on tape. If there is no BOT marker, attach one.

9. Press the ONLINE switch to make until available to the host. The switch may be pressed while the load operation is in progress. On completion of the load operation, the transport indicates the ONLINE status by turning the ONLINE indicator on. (If the transport is ready for a write operation, the FILE PROT indicator goes off.) The transport is now ready for use.
10. TA81 Only - Press either or both of the interface channel selection buttons (PORT A or PORT B) to select appropriate host interface channels.

3.3.3 Tape Unloading

The following are procedures for unloading tape manually or in on-line mode.

3.3.3.1 Manual Mode - Perform this procedure to unload tape manually.

1. Press the FAULT/RESET switch to place the transport off-line.
2. Press the UNLOAD switch. Tape moves in reverse direction (rewinds), gently winding onto supply reel until it clears the take-up reel and the tape path.

NOTE

If loaded beyond the BOT marker,
the tape rewinds to BOT.

3. Open the top cover and press the center button of the supply reel hub. The hub unlatches and the supply reel can be removed.
4. Close the top cover to prevent dust accumulation on the tape deck components.

3.3.3.2 On-line Mode - When on-line to the host CPU, the unload operation can be performed under CPU control.

3.3.4 Pump Shutdown

If the transport does not receive a new command from the CPU within one minute, the transport will automatically shut down its pressure pump (compressor) and remove power from the reel motors. Tape position will continue to be monitored by the transport microprocessor, and if motion of the take-up reel is detected, power will be reapplied to the take-up reel to re-null its position.

3.4 OPERATOR CORRECTIVE ACTIONS

If a fault condition is indicated on the control panel (RESET indicator is on and a fault code is indicated on the digital display), refer to the Fault Recovery Table on the inside of the top cover (also Table 3-2 below) and to the Fault Code Matrix, Table 5-2, in section 5.4 of this manual.

Table 3-2. OPERATOR CORRECTIVE ACTIONS

FAULT CODE	CORRECTIVE ACTION
E01 - E09	Clean magnetic head and tape path.
E10	Ensure cover door is securely closed.
E11	Thread tape.
E12	Latch supply reel hub.
E13	Thread tape correctly as shown on tape threading diagram.
E14	Check for BOT marker on tape. Attach BOT/EOT marker.
E15	Indicates RESET switch pressed inadvertently by operator. Reinitiate test.
E16	Check for presence of write enable ring in supply tape reel. Install the ring if not present.
E17	Check for presence of EOT marker. Attach EOT marker.
E18	Initiates that tape was loaded when test was initiated. Thread tape, but DO NOT press LOAD switch.
E20 - E29	Mount a tape of known good quality.
All Others	Attempt to run Diagnostic Test 01 (refer to section 5.4), and report the fault code to Field Service.

Section 4 - THEORY

4.1 GENERAL DESCRIPTION

This section discusses the operating principles of the TU81/TA81 Tape Transport. Descriptions are provided for all functions of the transport on a major component basis. Major areas of discussion are as follows:

- o Power Generation and Distribution
- o Pneumatic System
- o Servo/Control Module
- o Power Amplifier Module
- o Write Driver Module
- o Read Amplifier Module
- o Formatter Modules
- o Interface Controller Modules
- o Interface and Timing Considerations

Text is supported by diagrams, flowcharts, and timing charts. Diagrams are condensed and simplified, and in no way should be used for transport troubleshooting. Logic diagrams and schematics in the Field Service Print Set take precedence over any diagrams in the theory of operation. Refer to Figures 4-1A and 4-1B for a block diagram of the TU81/TA81.

A brief functional description of the major areas of the TU81/TA81 is given in the following paragraphs. A more detailed circuit description then follows with accompanying block diagrams and flowcharts.

NOTE

Appendix A of this manual contains a functional description of the TU81 Subsystem with emphasis on the TMSCP protocol. It also gives a short functional summary of the M8739 UNIBUS Adapter Module used on the TU81 subsystem. Appendix D provides a functional description of the TA81 Subsystem with emphasis on the STI protocol.

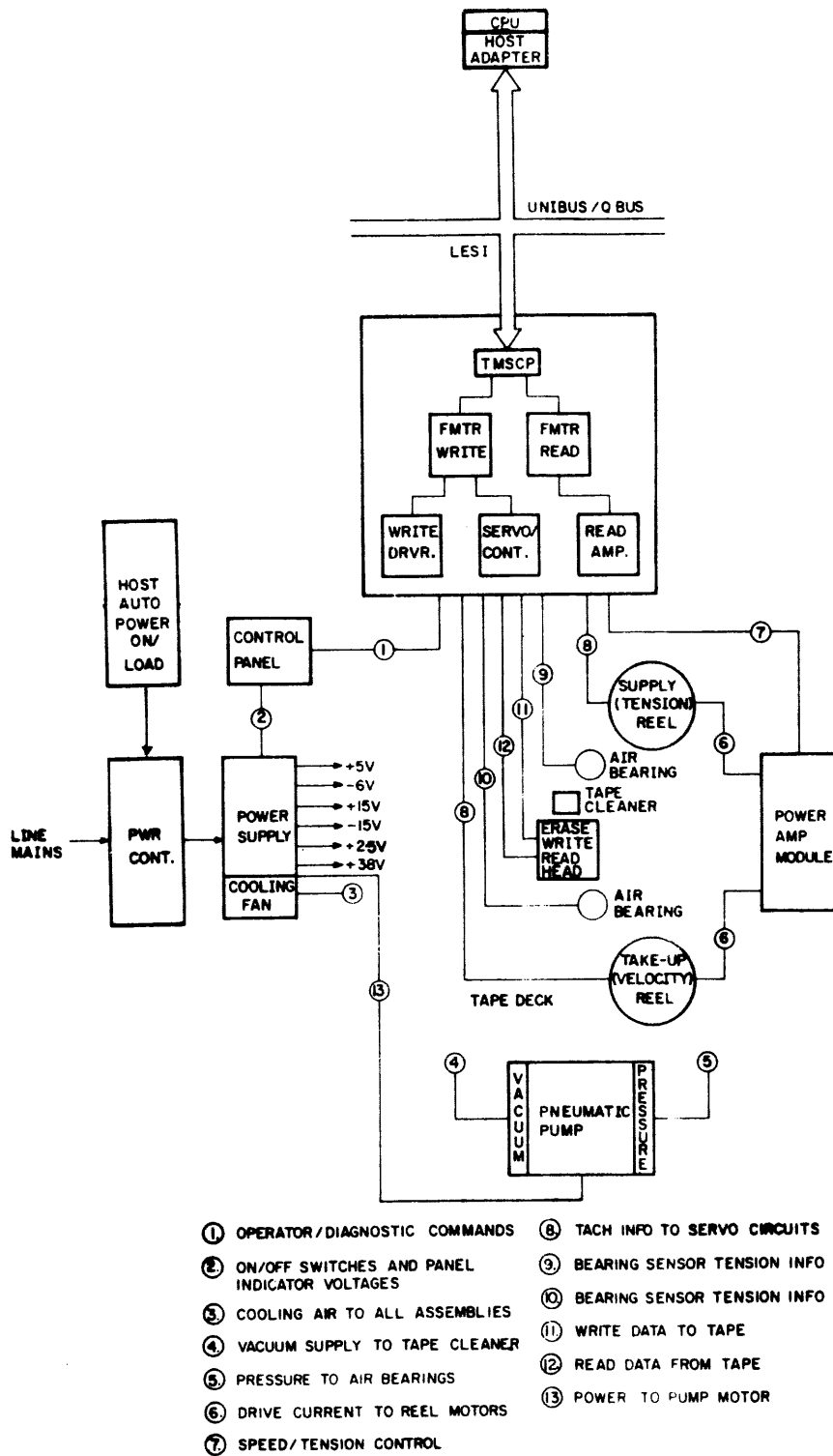

Figure 4-1A. TU81 FUNCTIONAL BLOCK DIAGRAM

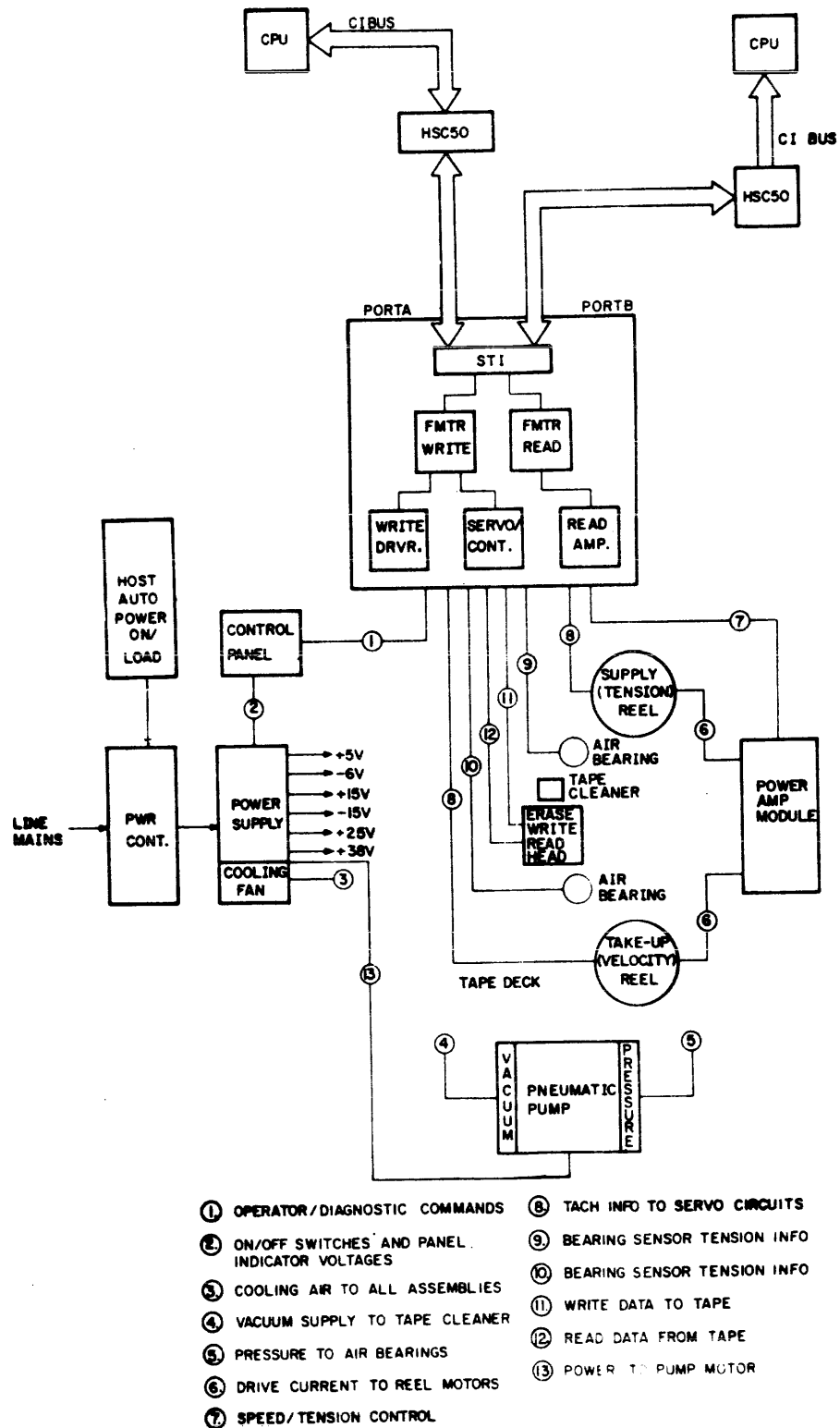

Figure 4-1B. TA81 FUNCTIONAL BLOCK DIAGRAM

4.2 PHYSICAL DESCRIPTION

The TU81/TA81 is a manual thread, autoload, reel-to-reel tape drive unit requiring no capstan drive, tension arms or vacuum columns. Tape is transported directly under electronic control, with no tape buffers required. Tension is sensed electronically by tension sensors built directly into the tape path. The major equipment components or subsystems are Control, Formatter and Controller Modules, Read/Write Head Assembly and Circuits, Pneumatics/Cooling Systems, and the Power Supply and Distribution Circuitry. The following paragraphs give a brief description of the overall transport functions.

4.2.1 Power Supply

The power supply is activated when the ON/OFF power switch (main circuit breaker) is in the ON position. This allows the LOGIC ON indicator on the control panel to illuminate, and also supplies the AC power to operate the cooling fan motor.

Pressing the ON/OFF power switch generates all the necessary DC voltages used throughout the TU81/TA81 logic circuits, as well as initiating a MASTER CLEAR pulse. This pulse is used to steer the control logic functions to a starting or known state prior to starting a Load operation.

An auto load feature built into the power supply allows the host system to perform a power-on, automatic load operation. At the conclusion of the autoload sequence, an ON-LINE status is indicated.

4.2.2 Tension/Speed Control

The Load function is initiated by the LOAD switch on the control panel when off-line, or by the host via the 874 Power Controller. The pneumatic pump is activated at this time, causing air pressure to be gated to the air bearings. Air pressure gated through holes in the bearings senses the tension of the tape through sensors physically located on the air bearings. The sensor output signals are applied to a tension servo circuit, whereby, the supply (file) reel is directed to drive so that approximately 8 ounces of tension is maintained across the tape path at all times.

Tape speed is maintained through the use of a 1000 line tach and a one-line tach located on the rear of the reel motors. Tach information is applied to an electronically controlled servo, whereby, a calculation is made of the linear velocity (inches per second) and the radius of the take-up reel. The radius of tape on the reel is always a known factor, therefore, linear velocity can be compensated for without the use of a capstan drive circuit.

4.2.3 Magnetic Head

The magnetic head fulfills the objective of the TU81/TA81; ie., read from or write to the magnetic tape. This assembly consists of a sectionalized read/write head and an erase head. Selection of the read or write modes of operation is made by the host through the control logic circuits. Data is transferred from or to the host via data lines that are gated to the individual read heads by the read/write circuits. Read recovery circuits convert the readback data to a digital format compatible with the control and formatter logic. Write driver circuits convert the logic-compatible write data to current levels required to drive the write head coils.

4.2.4 Electronic Modules

The electronic modules are divided physically into two sets; each set is housed in a separate cage. One cage contains the Formatter/Interface logic set consisting of the Formatter Write Module, Formatter Read Module, and Interface Controller Module. The other cage contains the Read/Write/Servo logic set consisting of the Read Amplifier Module, Write Driver Module, and Servo/Control Module.

4.2.4.1 Formatter/Interface Logic Set - The set comprises three modules.

In the TU81 subsystem transport, the Interface Controller Module uses the Tape Mass Storage Control Protocol (TMSCP). The TMSCP controller receives commands and data from the host, checks them for validity, and passes them onto the Formatter Modules. Also, the TMSCP Controller manages the flow of data and status codes from the transport to the host during read operations (see Appendix A).

STI Interface Module - The TA81 uses the Standard Tape Interface (STI) protocol. More information on this protocol will be published in the next revision of this manual.

The Formatter Write Module receives commands and data from the Interface Controller Module, translates the commands for the tape drive, and encodes the data into either PE or GCR format. The Formatter Write Module also generates tape control and identification signals, and error checking and correction codes.

The Formatter Read Module decodes the data from the PE or GCR format, and strips off the tape control and signal marks. The data is checked for errors and, if detected, the errors are corrected if possible, or the error condition is reported to the Interface Controller.

4.2.4.2 Read/Write/Servo Logic Set - The Read Amplifier Module amplifies the data signals detected by the magnetic head, and converts these analog signals to digital logic levels usable by the Formatter and Interface logic.

The Write Driver Module furnishes up to 140 ma of drive current to the write head with write compensation and ac bias up to 80 mA.

The Servo/Control Module receives, validates, and runs commands from the formatter. The Servo/Control Module also regulates the tape motion and responds to manually initiated commands from the control panel.

4.3 POWER SUPPLY

4.3.1 General Description

AC power from a single ac power outlet is supplied through a standard, 3-wire power cord (60 Hz only) to the 874 Power Controller at the bottom rear of the transport cabinet. The 874 Controller features a 12A (50 Hz) or 24A (60 Hz) circuit breaker, and provides regulated 120 Vac (60 Hz) or 240 Vac (50 Hz) to the power supply at the top rear of the cabinet. The 874 Power Controller is connected to the host CPU by a power switching cable. This gives the CPU control over the transport's power supply.

The power supply accepts regulated inputs of 120 Vac (60 Hz) or 220/240 Vac (50 Hz) power, with the only change in configuration being the positioning of the Voltage Select PC board. A functional description of this change is discussed in the following paragraphs. The major function of the power supply is to provide ac power to the cooling fan and pneumatic pump, generate dc voltages used throughout the transport, and provide shut-down capabilities in the event of abnormal voltage conditions.

4.3.2 Physical Description

Power supply components consist of the ac input receptacle, line filter, circuit breaker (mounted on the top rear of tape deck), Voltage Select PC board, main Power Supply PC board, and Power Supply Control PC board. A simplified block diagram of major power components is shown in Figures 4-2 and 4-3. A brief functional description of the three power supply PC boards follows.

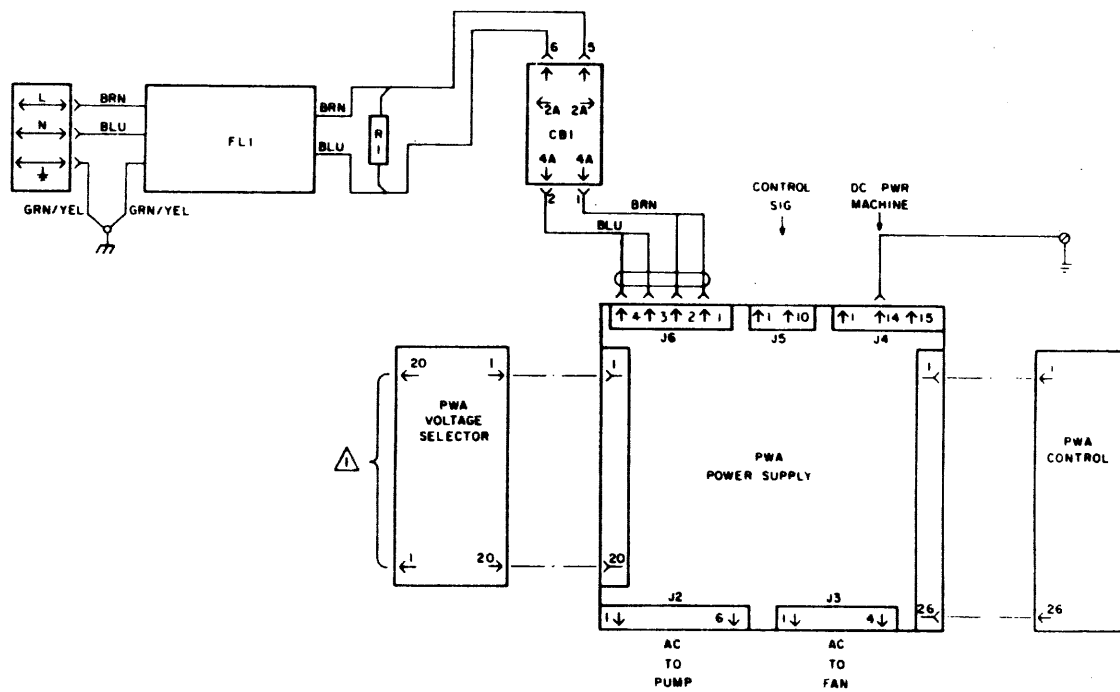

⚠ BOARD FLIPS FOR 120V, 60HZ, OR 220V, 50HZ

02A01-25

Figure 4-2. MAJOR POWER SUPPLY COMPONENTS

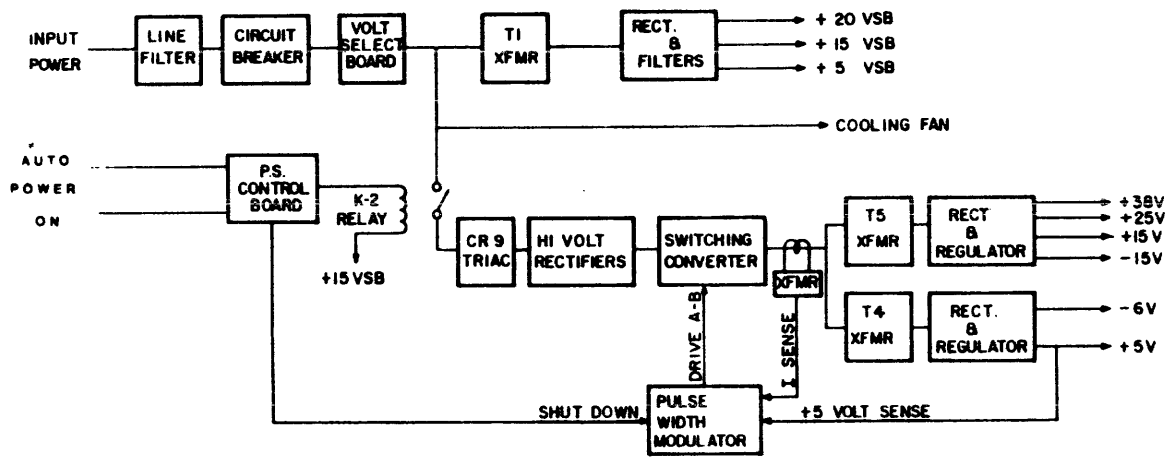

02-101-20

Figure 4-3. POWER SUPPLY BLOCK DIAGRAM

4.3.2.1 Voltage Select PC Board - This board consists of connectors J1A and J1B and fuses. The fuses are used in the input AC lines to a standby voltage supply and for protection of components in the internal high voltage circuit. The land layout of the board is such that the input lines from the line filter are matched to the input transformer in a configuration compatible with either 120 VAC (60 Hz) or 220/240 VAC (50 Hz). Connector J1A is inserted into the main PC board if 120 VAC is provided; connector J1B is used for the 220/240 VAC requirement. Connector keys are provided on the board edge connectors to eliminate the possibility of incorrect insertion. The Voltage Select PC board is mounted vertically into the power supply main PC board at connector J6.

4.3.2.2 Power Supply Control PC Board - The Control board consists of the low voltage and over-voltage detect circuits, Automatic Power-On circuits, LOGIC ON/OFF control panel indicator circuits, master clear circuit and power-on latching circuit. Like the Voltage Select PC board, the Control board is mounted vertically into the main PC board at connector J8.

4.3.2.3 Power Supply Main PC Board - The main PC board is responsible for the function of the power supply; i.e., generating DC voltages for all functions in the transport. A brief description of the circuits, comprising the main PC board, is as follows:

- o Standby Voltage Circuit - Standby voltages of +20, +15 and +5 volts are developed to provide a separate supply voltage for all other control circuits associated with the power supply. The standby voltages are used only within the power supply.
- o Pulse Width Modulator - This circuit monitors the +5 volt logic level and develops a pulse train to drive the half bridge switching converter. The pulse width modulator also provides the means by which abnormal conditions cause the shut-down of the output voltages.
- o Half-Bridge Switching Converter - This circuit contains the pulse width modulator, totem-pole driver circuits, high voltage rectifier, and transformers coupling the converted energy to the regulated DC voltage output circuits.
- o Regulated DC Voltages - The regulated DC voltages generated on the main PC board include +5V, -6V, +15V, +25V and +38V. The circuits consist of output transformers, full wave rectifiers, filtering networks and regulators.

4.3.3 Power Supply Functional Description

The following discussion of circuit operation is presented in the sequence in which the power supply is activated. Reference should be made to the accompanying block diagrams or to the Power Supply Schematics contained in the Field Service Print Package.

4.3.3.1 Input Power Selection - Input power (120V 60 Hz or 220/240V 50 Hz) is applied from the power line cord connected to the power supply receptacle and into a line filter for noise suppression. Power is then supplied to the transport power switch (circuit breaker) located on the tape deck. The switch portion of the circuit breaker is labeled 1 (ON) and 0 (OFF). With the circuit breaker placed in the 1 position, input power is routed through connectors and into the Voltage Select PC board. It is, at this point, that circuit selection is made for either 120 or 220/240 volts AC. Refer to Figure 4-4 for circuit differences.

If 120V 60 Hz input power is being applied, the Voltage Select PC board is positioned such that connector J1A is plugged into the main PC board. If an overload condition is present at transformer T1, the F3 and/or the F2, 1/8A fuses would blow. The fuses are situated so that any external taps of the primary (i.e., pneumatic pump operation) do not affect the fuses, which are used only for detection of an overload condition at transformer T1.

If 220/240V 50 Hz input power is being applied, then the Voltage Select PC board is positioned such that connector J1B is plugged into the main PC board. With this configuration, the two primaries of transformer T1 are wired in series, with only the F3 fuse applicable to the circuit.

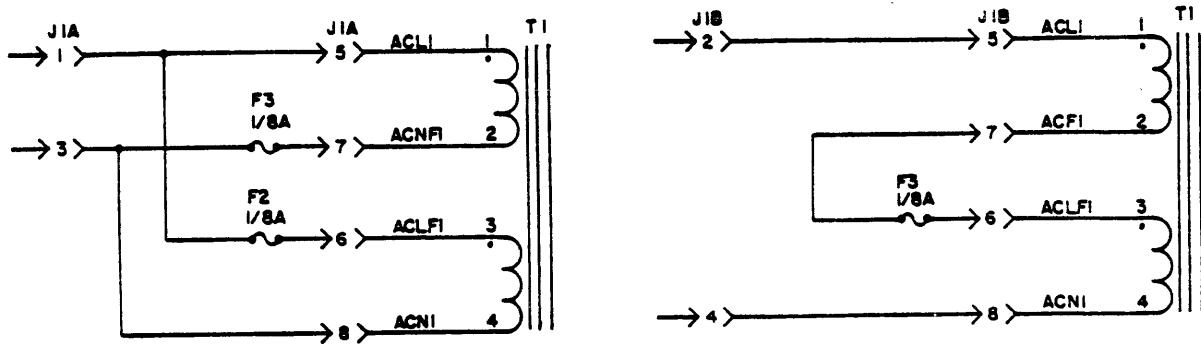

A. 120 VAC 60 Hz Power Input

B. 220/240 VAC 50 Hz Power Input

Figure 4-4. VOLTAGE SELECT PC BOARD

Also, note that at this point (power applied, circuit breaker ON), the ac line is applied to the cooling fan motor. The cooling blower has a three-line input and is configured as shown for either 120 or 220/240 volt application. Wiring to the neutral line is determined in the Voltage Select PC board (Figure 4-5).

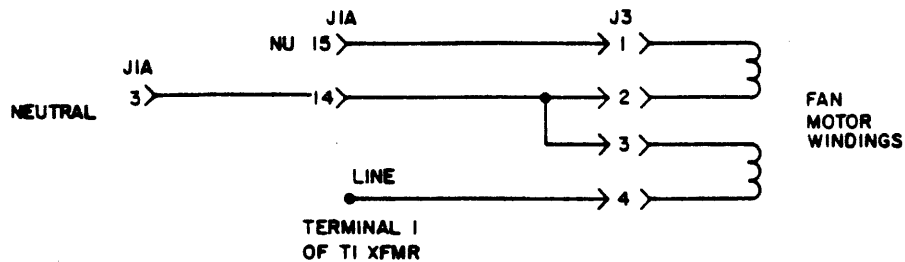

A. 120 VAC 60 Hz Power Input

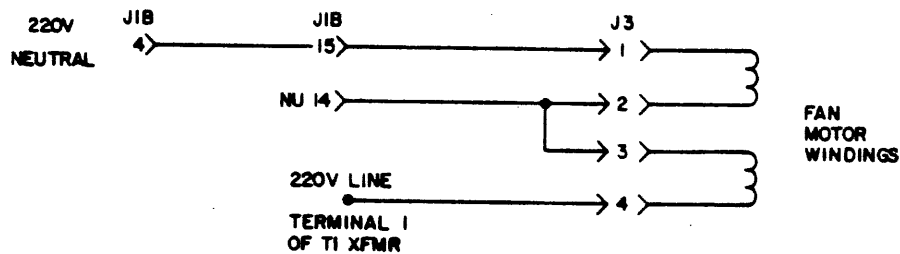

02A01-28

B. 220 VAC 50 Hz Power Input

Figure 4-5. COOLING FAN WIRING

4.3.3.2 Standby Voltage Generation - Standby voltages of +20, +15, and +5 volts are developed to provide a separate supply voltage for all control circuits associated with the power supply. These voltages are present when input power is applied and the circuit breaker is placed in the ON position. Development of the standby voltage is as follows.

Input power is applied to the T1 standby transformer and converted to a +20 standby voltage through a full-wave rectifier and filter network. The +20 VSB is used as a control voltage for the half-bridge switching converter and is used to develop the +15 standby voltage.

The +15 standby voltage is developed by a LM317 voltage regulator. The resistor divider network R3/R4 determines the required output of this regulator. Plus 15 volts is used as a supply voltage for the K-1 pump enable relay, K-2 current-on relay, pulse width modulator, over and under voltage detect circuits and master clear circuits, and is used as the source voltage to develop +5 standby voltage.

The +5 standby voltage is developed by a LM317 voltage regulator circuit similar to that used on the +15 VSB line. Plus 5 VSB is used as the supply voltage to operate all TTL chips used throughout the power supply. The Q3 transistor between the +5 and +15 volt circuits is used in the event of the +15 V supply being shorted to the +5 volt supply. If the +5 V supply increases above 6.2 volts, diode CR36 forward biases transistor Q3, causing a +5 V potential at the resistor divider network of the +15 VSB voltage regulator. The +15 VSB regulator then regulates to about 6.2 volts, eliminating any damage that would otherwise occur to the TTL circuits fed by the +5 V supply (Figure 4-6).

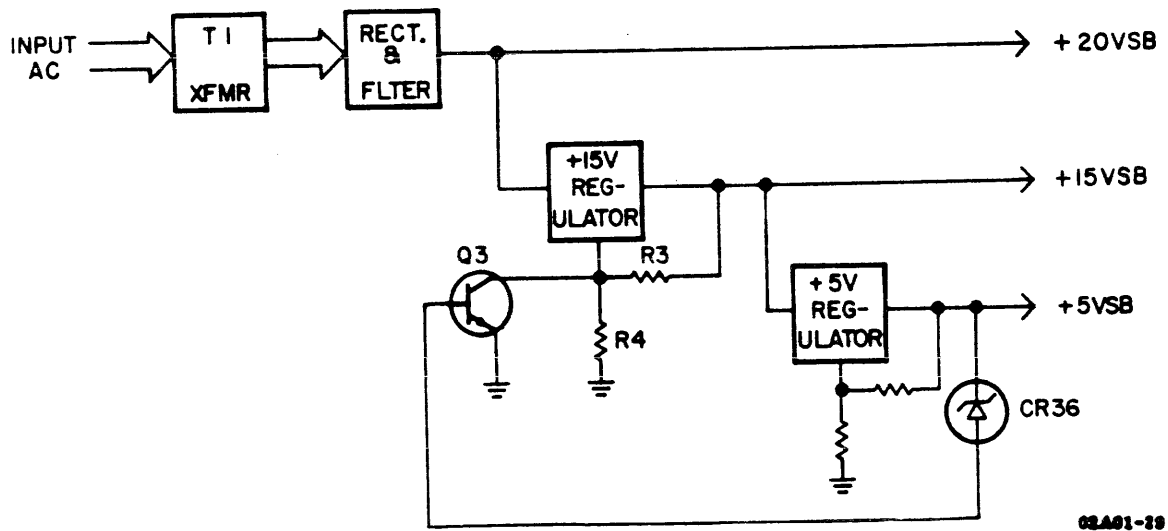

Figure 4-6. STAND-BY VOLTAGE GENERATION

The only effect of the standby voltage outside the power supply is the OFF indicator on the control panel. The Power-On flip-flop (reset at this time) turns on the OFF LED transistor and supplies current limited (20 ma) +20 VSB to the OFF indicator.

While in the standby mode, the ION signal is a logic 1 (High), keeping the pulse width modulator in a shut-down condition.

4.3.3.3 Power-On Sequence (Refer to Figure 4-7, Power-On Flowchart) - The purpose of the power-on function is to provide the required regulated DC voltages to the transport's control, formatter and servo circuits. The power-on sequence also enables the abnormal (low/over) voltage detect circuits within the power supply.

Power-On is initiated by pressing the main circuit breaker switch. This action causes a momentary turn on of the power-on transistor which triggers the POWER-ON flip-flop to the set state. The set output of the flip-flop removes the ION (low) signal from the pulse width modulator, enabling a 25 KHz pulse train output (DRIVE A/DRIVE B). These outputs are the control signals to develop the +5, -6, +15, +25 and +38 volt logic levels used throughout the transport. An explanation of the pulse width modulator and DC circuits are discussed in succeeding paragraphs.

Concurrent with the development of the DC voltages, the POWER-ON flip-flop also initiates a power-on delay, which is used to inhibit detection of low voltage until the DC voltages are expected to attain their nominal voltage level. The reset output of the POWER-ON flip-flop initiates a RC time delay of approximately 300 ms. This delay prevents the ON DLY flip-flop from setting which, in turn, forces the LVCHECK flip-flop to remain reset. At the conclusion of the 300 ms delay, a comparator triggers the ON DLY flip-flop. The LVCHECK flip-flop is now primed to receive a Low Voltage signal, if that condition is detected. Low voltage detection is discussed in succeeding paragraphs.

The ON DLY flip-flop also removes one of three inhibits from the Master Clear circuit.

The Master Clear (MCLR) circuit is provided to the transport logic to "steer" the control functions to a starting or known state during ON/OFF and other detected abnormal conditions. The MCLR circuit contains a time delay circuit of approximately 150 ms, which is used to assure output voltage stability prior to inactivating Master Clear. Three inputs are used to control MCLR: PON (Power On flip-flop), LOWV (Low Voltage), and ONDLY (On Delay flip-flop). The output of the MCLR is held low active during transitional periods, and is allowed to de-activate to a high level after all three controlling inputs are logic high.

At the conclusion of Master Clear, the ON LED transistor is turned on which applies +5V to the LOGIC ON indicator on the control panel.

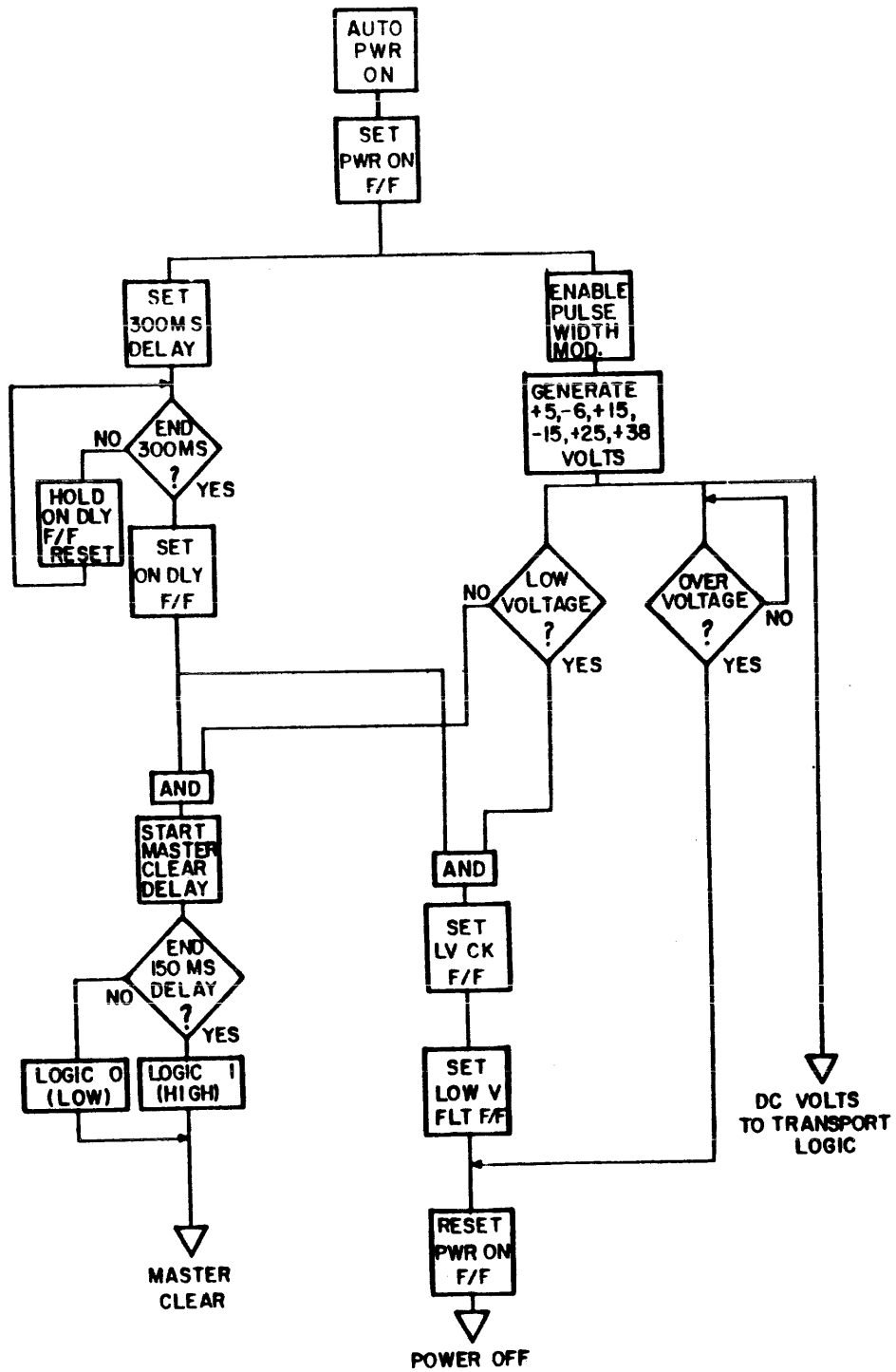

02A02-30

Figure 4-7. POWER-ON SEQUENCE FLOWCHART

4.3.3.4 Switching Converter (Refer to Figures 4-8 and 4-9) - The high voltage supply for the switching converter consists of two electrolytic capacitors charged through a diode bridge network. The output capacitors are configured such that during 120V operation, the circuit functions as a voltage doubler, with the output capacitors connected in series. During 220V operation, the output capacitors are connected in parallel, and the input line is full-wave rectified. The resulting effect is that an output voltage of approximately 300V is supplied to the switching converter, regardless of whether 120V or 220 VAC is supplied. A simplified diagram of output capacitors and bridge configuration is shown in the figures below.

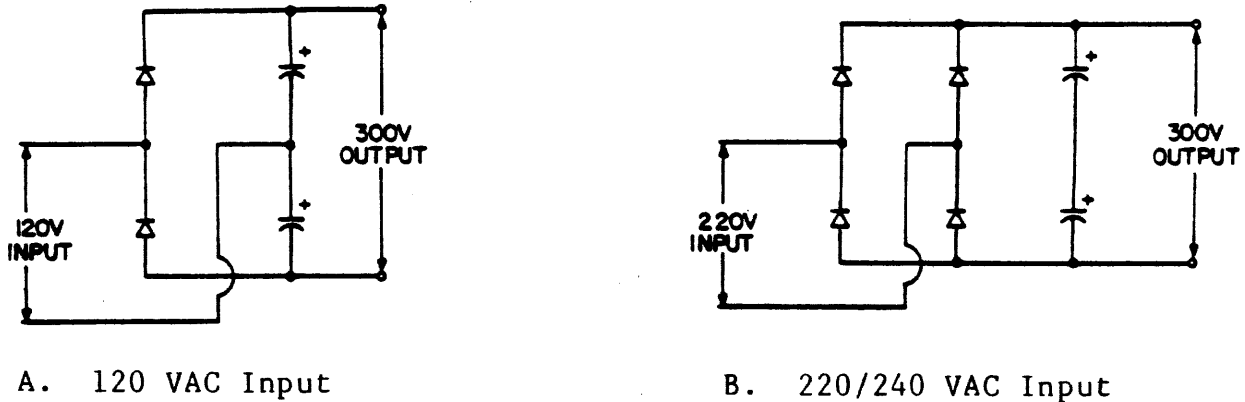

Figure 4-8. HIGH VOLTAGE GENERATION

DRIVE A and DRIVE B (from the pulse width modulator) appear at the input of two peripheral drivers. These drivers, in the on state, positive input, provide a ground output. In the off state, the output is an open collector circuit. An example of circuit operation is as follows: As the signal level of DRIVE B goes negative, driver output becomes an open collector. This provides a circuit from R12, +20 VSB, through the primary of transformer T2, to ground of the output of the opposite peripheral driver. With terminal 2 of T2 at a positive potential, an induced positive voltage is also present at terminal 10 of the secondary of T2, causing transistor Q1 to turn on. With Q1 turned on, a current path is now provided via Q1, T2 windings 5 and 6, and through the primaries of transformers T4 and T5. The induced voltage in the secondary of T4 and T5 is rectified, as described in the DC Voltage paragraph. During conduction of Q1, the current flow through T2 terminals 5 and 6 applies a "load proportional" drive current to base of Q1.

DRIVE B peripheral driver is turned on (ground output) when the DRIVE B signal returns to the high level. With both DRIVE A and DRIVE B in the on state, the primary of T2 is essentially shorted, causing Q1 to turn off. The charge stored in capacitor C10, during conduction of Q1, is applied as a back bias to Q1 when T2 is shorted. This ensures an immediate turn off of Q1 to produce the resultant waveform shown in Figure 4-9.

When DRIVE A signal goes negative, the peripheral driver pin 3 outputs an open collector, and a current path is provided in the opposite direction through transformer T2 primary winding. Terminal 7 of T2 secondary now has a positive reference and Q2 is turned on. Current flow through T4 and T5 is now in the opposite direction via Q2 and T2 windings 5 and 6.

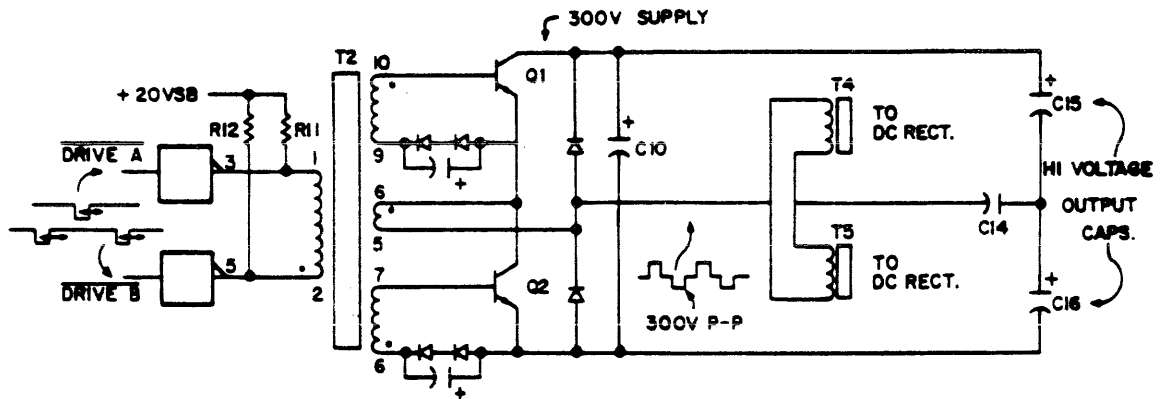

Figure 4-9. SWITCHING CONVERTER CIRCUIT

4.3.3.5 DC Voltages - The DC voltages generated by the power supply, for use throughout the transport, are as follows:

<u>VOLTAGE</u>	<u>USED ON</u>
+5V	All modules as a supply voltage for TTL circuits
-6V	Read Amplifier Circuits
+15V	Servos, Power Amplifier and Read Recovery VFO
-15V	Servos and Power Amplifier
+24V	Write Driver Circuits
+38V	Power Amplifier

All DC voltages are generated and regulated in a similar manner. The output of the secondary windings of the Switching Converter transformers T4 and T5 are inputted to a full wave rectifier and filtered by a choke/capacitor filter network. Negative 6 volts and + 15 volts are regulated by LM317 and LM337 voltage regulators, with resistor divider networks providing the required regulator programming. Plus 5 volts circuit does not require a voltage regulator due to the compensation circuit supplied by the pulse width generator discussed previously.

4.3.3.6 Low Voltage/Over-Voltage Detection - The detector circuits are comprised of the various DC input voltages, voltage divider resistor networks, +2.5 reference voltage and LM339 voltage comparators. If any of the input DC voltages exceed the circuit threshold set up by the resistor networks and reference voltage, the comparator outputs a ground potential. This output then initiates a shut-down of the transport power supply. If the voltages are within the parameters listed below, the comparators will have open outputs.

<u>NOMINAL VOLTAGE</u>	<u>LOW VOLTAGE THRESHOLD</u>	<u>OVER-VOLTAGE DETECTION</u>
+5V	+4.53	+6.0
-6V	-5.0	-6.96
+15V	+12.58	+17.25
-15V	-12.58	-17.25
+25V	+21.25	+28.13
+38V	+25.25	+50.3

4.3.3.7 Power Supply Shut-Down - There are two circumstances which cause the transport to power-down. They are an over-voltage condition and a low voltage condition.

- o Over-Voltage - When an over-voltage condition occurs, the voltage comparators of the detection circuit output a ground potential. This ground signal (labeled OFF) resets the POWER-ON flip-flop. Signal ION becomes a logic 1 (high), causing the pulse width modulator to shut down. With no output from the modulator, all DC voltages to the transport are dropped. Concurrent with the shut-down of the pulse width modulator, the Master Clear signal goes to a logic 0 (low), thereby resetting affected circuits in the transport logic. The LOGIC OFF indicator on the control panel is illuminated by the shut-down condition.
- o Low Voltage - When a low voltage condition occurs, the voltage comparators of the detection circuit output a ground potential. This ground signal (labeled LOWV) sets the Low Voltage Check flip-flop, if the ON DLY FF is set, causing LV FAULT FF to set which results in the POWER-ON flip-flop going reset. With POWER-ON flip-flop in the reset state, the power supply is shut down in the same manner as described in the Over-Voltage discussion above.

4.4 PNEUMATIC SYSTEM

4.4.1 Functional Description

The pneumatic system generates and distributes the air pressure and vacuum requirements of the transport. The pneumatic system consists of a carbon-vane centrifugal pump, tape cleaner intake port, filter/regulator assembly, and pressure ports of the air bearings.

The pneumatic pump is enabled by the microprocessor during the load sequence. A PUMPEN signal from the logic energizes K-1 relay located in the power supply. The contacts of K-1 relay triggers a triac which gates the single phase input power to the pump motor. Motor wiring is configured for 120 or 220/240 volt input via the Voltage Select PC board in the power supply.

With the pump motor operating, the air intake (vacuum) side of the pump is from the tape cleaner assembly. Refer to Figure 4-10 for a block diagram of vacuum and pressure distribution. In addition to the tape cleaner intake, a small bleeder hole exists on the elbow fitting between the pump and plastic hose from the tape cleaner. The vacuum effect at the tape cleaner is approximately 8.0 inches H₂O.

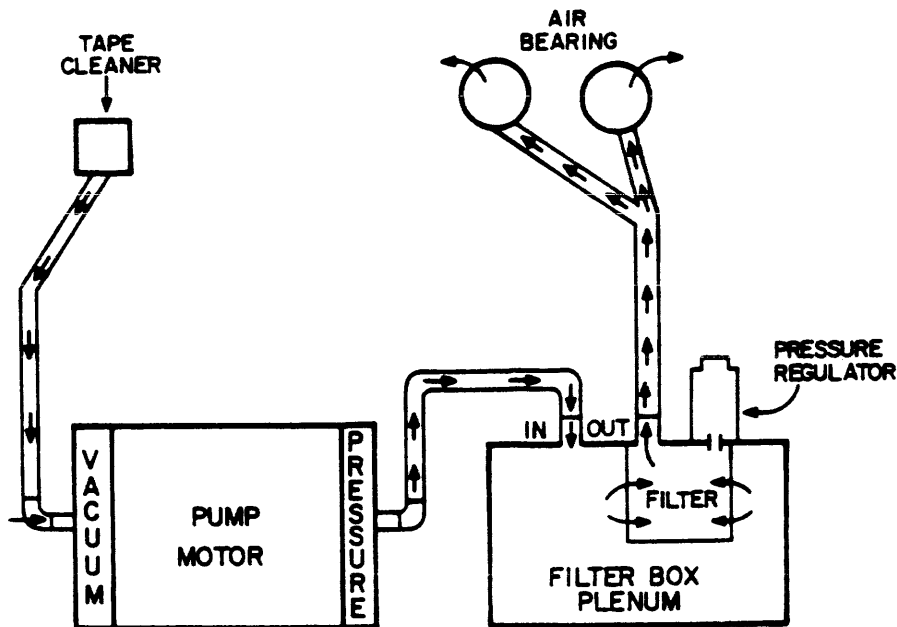

02A01-33

Figure 4-10. VACUUM AND PRESSURE DISTRIBUTION

The regulator part of this assembly is a spring-controlled valve that causes any pressure above 2.0 PSI to be bled out of the system. The air pressure is filtered by a hepa filter, acting as a high efficiency particle accumulator to clean the air before application to the air bearings. Air is forced through the filter and a hollow shaft. One end of the shaft is open and contacts the bleeder valve so that pressure in excess of 2.0 PSI is removed. The inside area of the filter (now regulated to 2.0 PSI) is applied to the deck plenum which directs the air pressure to the air bearings.

4.4.2 Pneumatic System Operational Description

Operation of the pneumatic system is obtained through the power supply by the presence of 15 VSB and low active -PUMP signals. Together, these signals energize K-1 relay and trigger triac CR8. The output of triac CR8 provides the pump with the single phase operating voltage.

Figures 4-11A and B show motor wiring configurations for 120 or 220/240 volt inputs via the Voltage Select PC board in the power supply.

In the 120 V mode of operation, single-phase input power is applied to the motor through pins 2 and 6 of connector P2. During initial motor start-up, an external 5 uF capacitor is used to create a phase difference. In this configuration, the capacitor is connected in series with the start motor winding.

V.S.B 120V APPLICATION (JIA)

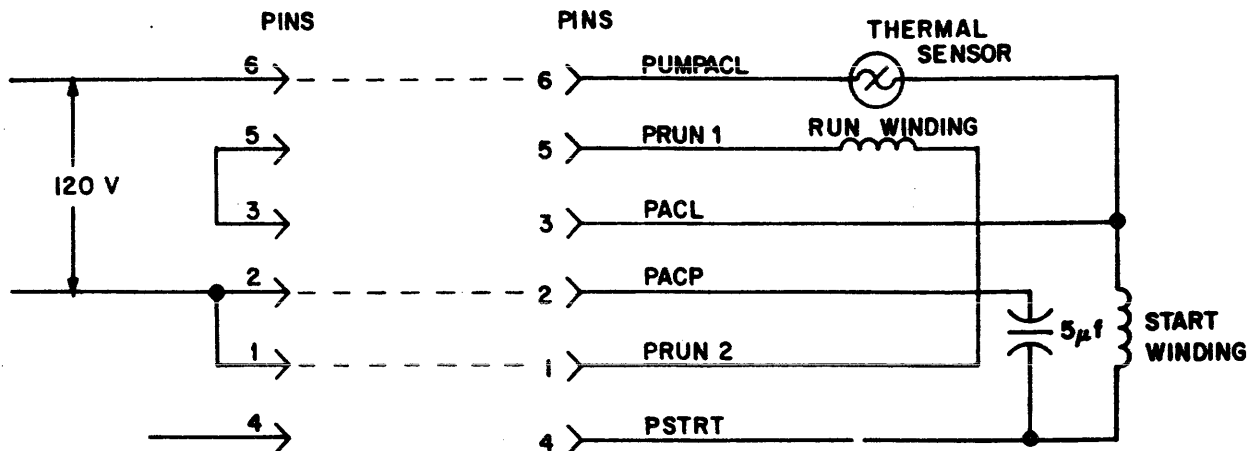

Figure 4-11A. PNEUMATIC PUMP WIRING 120 VAC CONFIGURATION

In the 220/240V mode of operation, single phase input power is applied to the motor via pins 5 and 6 of connector P2. During initial motor start-up, an external 5 uF capacitor is utilized to create a phase difference. In this configuration, the capacitor is connected in parallel with the start motor winding. For both configurations, the pump motor contains a self-recovering thermal sensor.

V.S.B 220V APPLICATION (JIB)

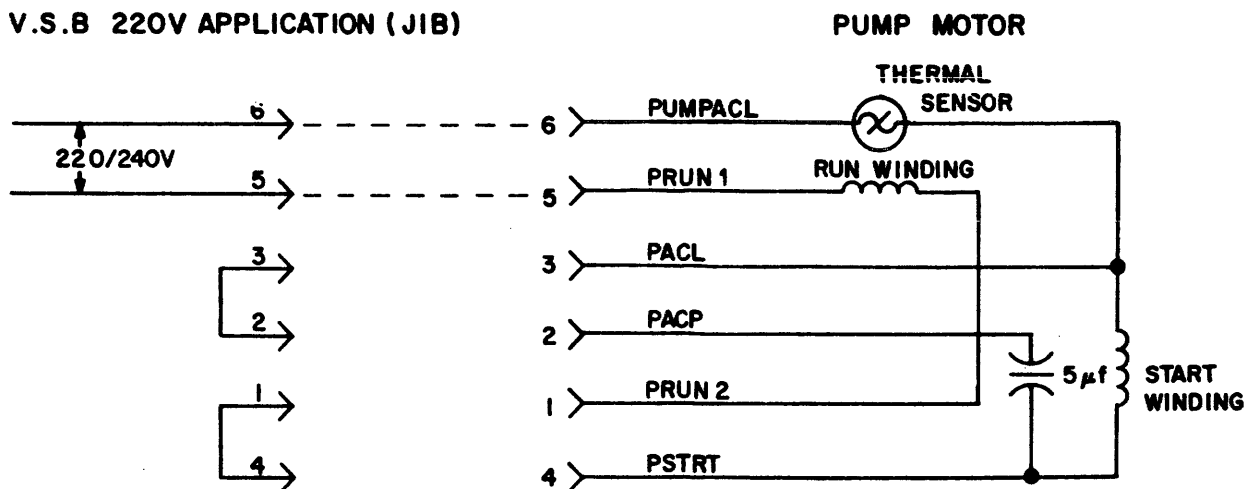

Figure 4-11B. PNEUMATIC PUMP WIRING 220 VAC CONFIGURATION

4.5 SERVO/CONTROL MODULE

4.5.1 Introduction

The Servo/Control module has four main functional areas of responsibility in the overall operation of the transport. They are as follows:

- o Formatter Commands/Responses
- o Transport Control/Monitoring
- o Control Panel Command Execution
- o Tape Motion/Servo Control

4.5.1.1 Formatter Commands/Responses - The transport must accept, validate, and dispatch for execution commands transmitted by the formatter. For commands such as Write and Read Reverse, the module must determine, sequence and monitor the necessary tape motion to complete these commands. Communication between the formatter and transport is controlled by the respective Servo/Control and Formatter Write module microprocessors.

4.5.1.2 Transport Control/Monitoring - The Servo/Control module must respond to each of the outputs generated by the various sensors located throughout the drive. Some of the responses include BOT/EOT, File Protect, updating of the take-up reel radius dependent parameters, and the initiating of a verification sequence for a potential fault condition.

4.5.1.3 Control Panel Command Execution - The Servo/Control module communicates with the operator or customer engineer through the control panel to allow execution of manually initiated commands. These commands include the loading and unloading of tape or the executing of various diagnostic tests.

4.5.1.4 Tape Motion/Servo Control - In addition to the global activity of overseeing tape activity, the servo control logic becomes embedded in the take-up reel motor servo during stoplock and tape acceleration/deceleration. The Servo/Control module monitors tape speed and provides compensation for underspeed/overspeed conditions to ensure constant speed during all tape motion operations.

4.5.2 Microprocessor (Figure 4-12)

The 6802 microprocessor (uP) is the controlling entity on the servo/control module. The microprocessor features include two 8-bit accumulators to form a 16-bit accumulator, two 16-bit index registers, a user stack pointer, a hardware stack pointer, and an 8-bit direct page register. The microprocessor has no internal RAM, is operated off a 4 MHz crystal, and has 3-level priority interrupt inputs. All inputs and outputs of the 6802 and all other devices on the uP bus are TTL compatible. Output or bi-directional devices connected to the uP bus have tri-state drivers which only get enabled as a function of the uP, E, and Q clock outputs.

The input, output, and control lines extend out to the various peripheral and memory devices. Device selection is obtained by decoding a part of the uP address bus and gating it with the E and Q clocks.

A 6821 Peripheral Interface Adapter is used for communication between the Servo/Control uP and Formatter Write uP. The PIA's 16 bi-directional, peripheral data lines (ports A and B), interrupt line (CA1), and peripheral control (CB1 and CB2) are used to establish a handshake communication between the two boards. The drive uP gains the attention of the formatter by use of the INTR line which causes the formatter to interrogate the drive status/sense to determine cause for the interrupt.

For the processor to count servo tachs (forward and reverse) for tape acceleration, to maintain positional information during repositions, and to provide a real-time clock for the processor, two 6840 Programmable Timer Modules are attached to the uP bus and control lines. The PTM contains three 16-bit counters which provide various modes of operation including squarewave generation, gated delaying of signals, digital single-shot pulse generation, and pulse width modulation. The counters decrement on each clock period.

The functional and diagnostic programs for the processor reside in two Read-Only-Memory (ROM) chips. When the ROM is enabled by the processor (through the address decoder), the data relative to the current processor address is conveyed to the data bus by the ROM within one uP cycle time.

Various Medium Scale Integration (MSI) devices are attached to the processor data and address bus to allow the uP to interface to the servo, read, and write hardware. The MSI devices consist of bit input multiplexers, bit output latches, byte output latches, and related address decoding devices.

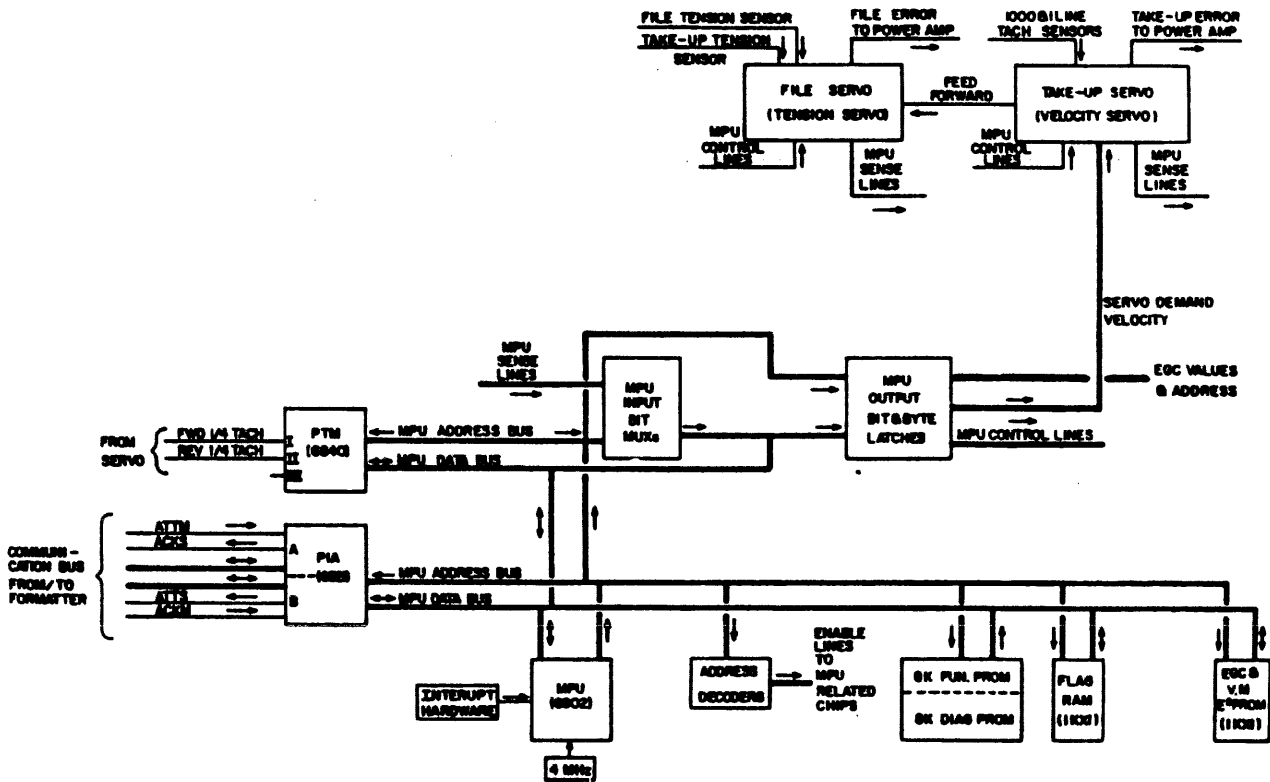

Figure 4-12. SERVO/CONTROL BLOCK DIAGRAM

Single input data bits are passed through the bit input multiplexers to the uP data bus bit 7 (the most significant bit), upon selection of an input multiplexer. The selection of a given data bit and multiplexer is dependent on the address conveyed by the uP to the multiplexer and address decoding devices.

Bit output latches are used to convey bytes of data from the uP to the hardware. No connection to the uP data bus is made. The selection of a given bit output latch is dependent on the address conveyed by the processor to the latch and address decoding devices. All latches are reset by the master reset line.

Byte output latches are used to pass bytes of data from the processor to the hardware. Output data is derived from the uP data bus upon a write operation to the byte output latch address. The selection of a given byte output latch is dependent on the address conveyed by the uP to the address decoding devices.

A nonvolatile 1K X 1 bit static RAM (E2 PROM 2201A) is attached to the processor to provide both a means of storing the read amplifier gain values, velocity servo gain adjust multiplexer and write driver current levels, and a means of storage of flag bits used by the uP to retain transport status. A 2-position jumper is provided to prevent unintentional changes to the data contained in the E2 PROM. Data can only be transferred to the E2 PROM with the jumper in the "STORE" position.

4.5.3 Velocity Servo (Figure 4-13)

The velocity servo consists of a digital-to-analog converter (DAC), decode flip-flops connected to a digital tachometer, operational amplifiers, and three presettable counters. The DAC converts eight bits of information labeled "Demand Velocity" (DMDVEL) into a signal proportional to the desired velocity. The demand velocity can vary from 0 to 255 with complete control at any speed. The DAC output at 25 ips is 1/2 volt per radian per second. A radian per second is derived from the linear tape velocity (ips) divided by the radius of the take-up reel.

At the beginning of tape (BOT), the radius is 2.56 inches. At the end of tape (EOT), the radius is about 4.9 inches when using a 2400 foot reel of tape. The voltage at the output of the DAC is about 4.88 volts at 25 ips (speed divided by 2.56 inches) at BOT and 2.5 volts at EOT. The voltage at the DAC output does not change when 75 ips is selected; however, the rotational speed changes accordingly. The signal REV determines the polarity of the analog demand velocity signal for rotation of the take-up motor in each direction.

Rotational velocity is generated and referred to as "analog tachometer" (ANALOG TACH). The ANALOG TACH signal (TP9) is also proportional to 1/2 volt in the 25 ips mode. In the 75 ips or rewind mode, the analog tach is less than the rotational speed. The analog tach is derived from the 2-phase, 1000-line tachometer physically mounted on the rear of the velocity motor. The output signals, phase A and phase B, are decoded into direction and divided down (depending on the speed selected). The divided tach triggers a 128 microsecond one-shot. The decoded direction is logically Anded with the 128 microsecond one-shot and then filtered to become the analog tach.

The analog tach is subtracted from the demand velocity and compensated with a lag-lead filter. This signal is then multiplied by 2 or 6, depending on the speed and becomes the take-up error (TUER). The take-up error is proportional to the desired current in the velocity motor and is equivalent to 1.0 volt per amp.

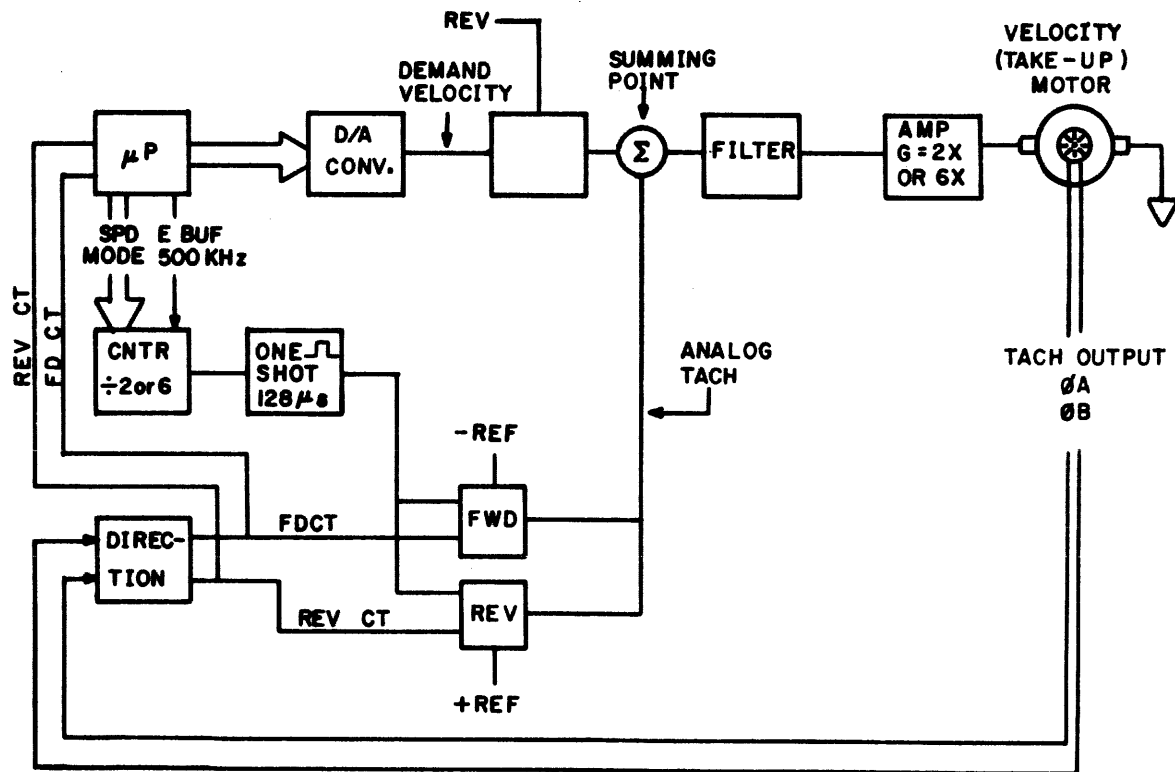

02801-126

Figure 4-13. VELOCITY SERVO - SIMPLIFIED

4.5.4 Tension Servo (Figure 4-14)

The tension servo system is comprised of two tension servo transducers, input operational amplifiers, reference voltage inputs, take-up motor error input, summing circuit, analog switch circuit for mode selection, and above/below tension level comparators for servo shutdown in the event of component failure.

The two tension sensors are on either side of the magnetic head. One sensor is between the velocity servo motor (take-up reel) and the magnetic head, and the second is between the tension servo motor (supply reel) and the magnetic head.

During a load sequence, before starting the pump motor, the microprocessor sweeps TTENOFF and FTENOFF levels from their maximum voltage to the minimum voltage. At the point at which the TTENOFF and FTENOFF zero their respective operational amps, the TTENZERO and FTENZERO signals toggle causing the microprocessor to stop the changing sweep levels. The effect of this action is to determine the point at which both tension transducers have a zero offset. The microprocessor maintains the TTENOFF and FTENOFF levels at the determined offset until the next load sequence.

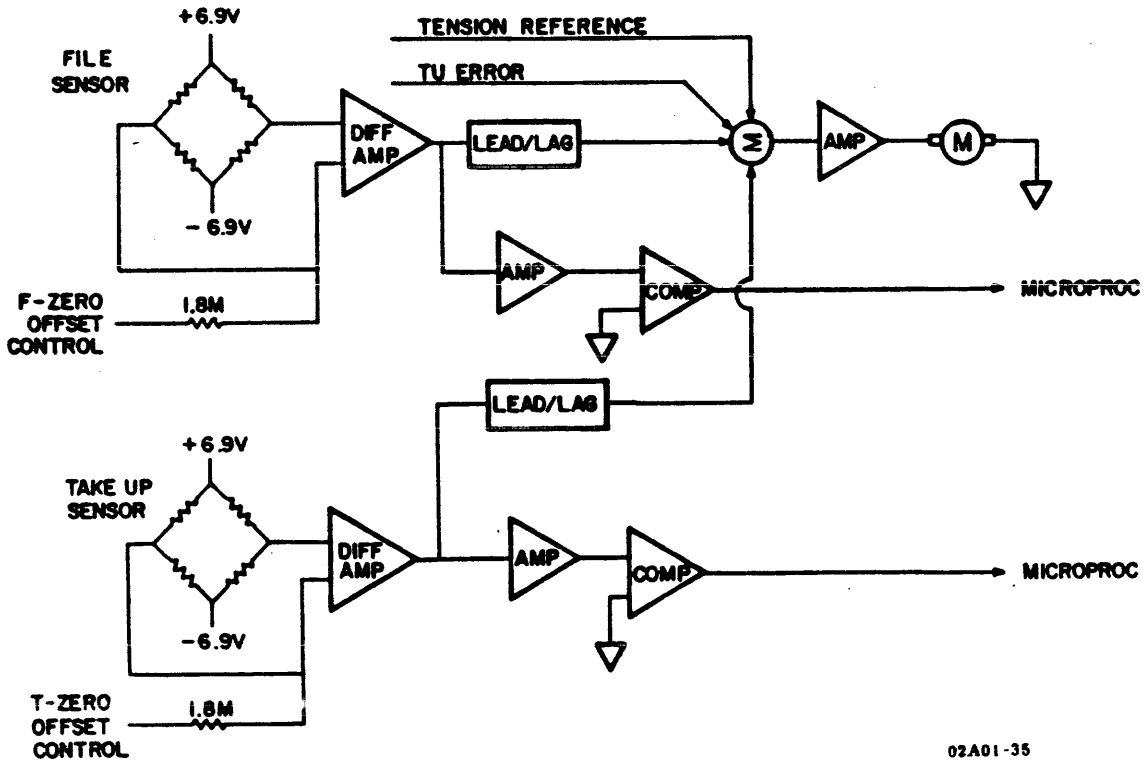

Figure 4-14. TENSION SERVO - SIMPLIFIED

The inputs to the tension servo circuit are TTENTRANS, FTENTRANS, + REF and TUER. The TTENTRANS and FTENTRANS signals come directly from the tension sensors with a signal input proportional to the variance of tension felt by the sensor. The tension reference is derived from a 6.9 volt supply and a 1.78M ohm resistor. This reference voltage is equivalent to 16 ounces of tape tension, and is used to bias the circuit so that 8 ounces of tension is developed. The fourth input is the TUER signal and is proportional to the current in the take-up motor at any given time.

At an optimum condition, where both sensors are sensing 8 ounces of tension, the 16 ounce (+ REF) reference is effectively neutralized. The only dynamic effect on the circuit, at this time, would be the action of the take-up reel motor. With the TUER being summed with the neutralized tension/reference voltage inputs, the tension motor (supply) reacts proportionally to the current in the take-up motor, as indicated by TUER.

Any variance in tape tension would cause a change in the sensor op amps' outputs. This voltage output is subtracted from the tension reference, with the result summed with TUER. The difference of all these signals is multiplied by a high gain amplifier when tape is in motion.

The PRKD input term to the tension servo is active during a Parked or No Tape Motion condition. With PRKD active, the operational amplifier used as a high gain multiplier, after the summing network, is switched to a low gain amplifier.

The above/below tension limit protection circuits consist of a series of comparators, with inputs referenced to predetermined voltage levels corresponding to high or low tension levels. If above or below tension levels are sensed on either of the tension sensors, the microprocessor is notified via signals TAUTL, TBLTL, FAUTL or FBLTL and a shut-down of the servo is initiated.

4.6 POWER AMPLIFIER MODULE

The function of the Power Drive module is to convert voltage error values received from the Servo/Control module into proportional currents driving the take-up motor and the supply (file) motor. The torques created by the motors are applied as acceleration and tension to the tape between the two motors. The Power Drive module's electronics assembly consists of two identical amplifiers. The operation of one amplifier is described below.

The amplifier has an H-bridge voltage switcher driven by a Pulse Width Modulation (PWM) converter contained within a current feed-back loop. The resulting current is uninterrupted, but varies with an average value proportional to the input voltage, with a gain factor of 1 amp per volt. A soft dead-band of + 300 mv exists where the gain factor quickly approaches zero within this region of input.

An overall block diagram is shown in Figure 4-15. The signal flow proceeds from the differential error input through U1 with Unity Gain Summing, with the current feed-back voltage from U2. The resulting difference is multiplied by five through U3 and compared to two triangle voltages by comparators U4 and U5.

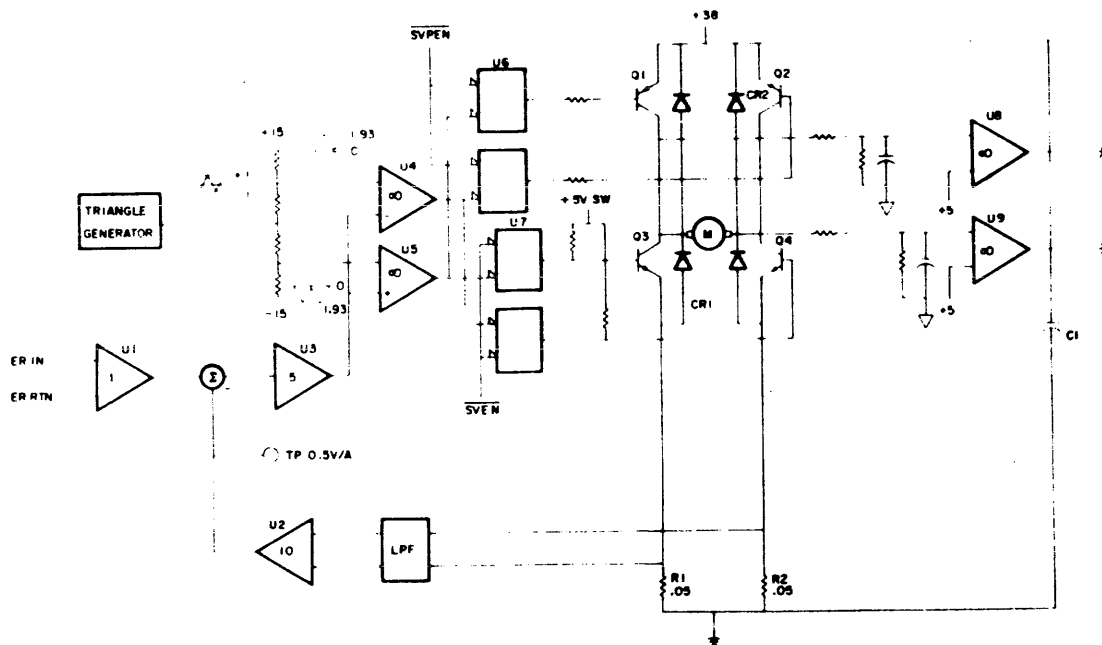

Figure 4-15. POWER AMPLIFIER BLOCK DIAGRAM

These waveforms are shown in Figure 4-16. Two quadrants of input are shown to point out that only one of the negative-active outputs from U4 and U5 exists at any given time. The peripheral drivers U6 and U7 connect the PWM outputs from the comparators to the appropriate transistors Q1 through Q4. At this point, it can be seen how the enabling to the H-bridge is performed. The gating of $\overline{\text{SVPEN}}$ and $\overline{\text{SVEN}}$ allow diagnostic control. The SW5 signal (Switched +5 Volts) is applied as the source of drive to the lower bridge. It can be quickly removed during Power On and Off sequencing or during a high over-current condition.

The circuitry for providing SW5 is shown in Figure 4-15. Motor current is sensed through the appropriate resistor R1 or R2 and connected to U2 through a low-pass filter. The filter removes switch-over spikes caused by shorting currents through commutating diodes CR1 through CR4 and non-aligned switching times of the two transistors in any one diagonal. The filter plays no part in compensation for loop stability or rejecting the 20 KHz current ripple.

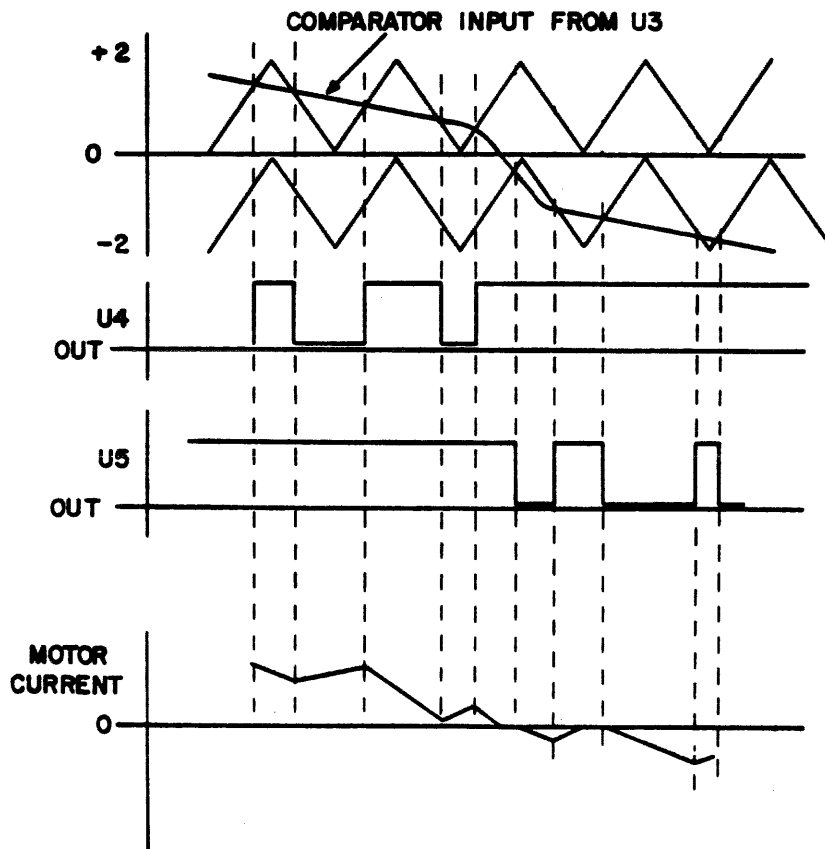

Figure 4-16. POWER AMPLIFIER WAVEFORMS

Figure 4-17 shows a quadrant of the H-bridge and the states of current flow for a given dc input. In State 1, current is flowing in Q1 and Q4, 'charging' the motor. In State 2, the motor is 'discharging' through CR1 and CR2 and through CR3, thus charging C1. It should be noticed that the capacitor C1 is discharging during State 1. The capacitor is also charged by the power supply during State 2.

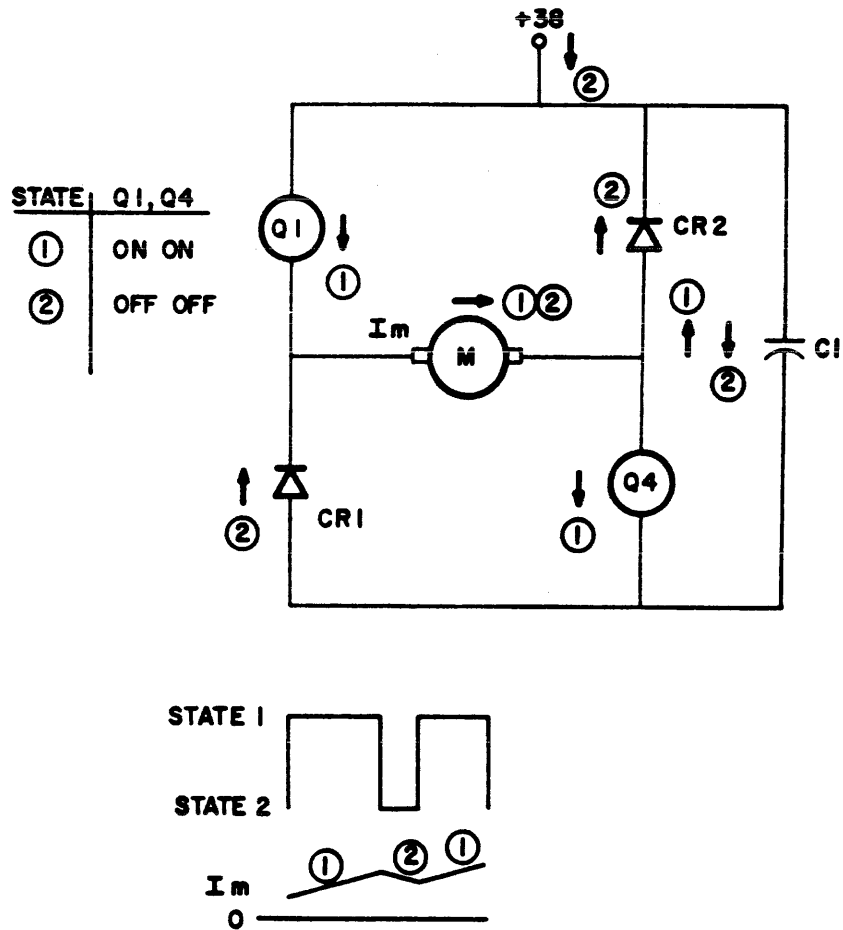

Figure 4-17. H-BRIDGE SWITCHING

A block diagram of the Switched 5-Volt line for biasing the lower stages of the H-bridge, and also the peripheral drivers for biasing the upper stage, is shown in Figure 4-18. The 5-volt shut-down is needed because the peripheral drivers become uncontrolled below 4 volts, thereby turning on both sides of the bridge in the presence of 38 volts. The MASTER CLEAR signal from the power supply and the over-current one-shot also make use of comparator U4 for shut-down. If more than 20 amps flow in any sense resistor for longer than 5 microseconds, one-shot U3 is triggered, which extends for 0.5 second and prevents the comparator from turning off U5 for that time.

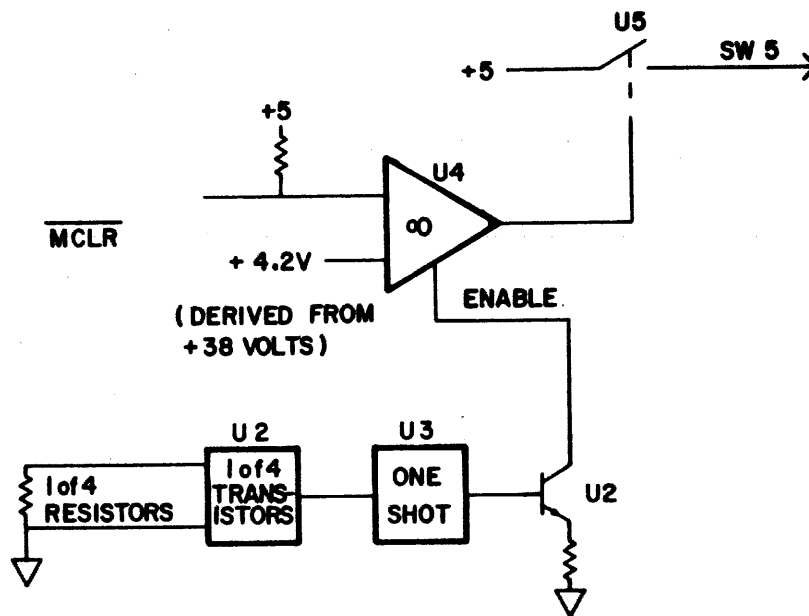

Figure 4-18. SWITCHED +5 VOLTS

4.7 WRITE DRIVER MODULE

The function of the Write Driver Module is to convert the digital data received from the formatter to an analog write current for writing data on tape. The Write Driver contains the necessary control circuits for generating the required voltages and currents used internally to perform the write data function.

4.7.1 Write Control

The control circuits are enabled by the absence of both File Protect and Rewind as shown in the Write Control block diagram (Figure 4-19). The absence of these signals, along with a +24 volt supply, turn on transistors E1/Q1, outputting a voltage greater than +22 volts. This voltage is used along with ERASE to enable erase head current and the erase current detect output at TP2. The +22V is also an input to a voltage regulator for generation of +15V. This voltage is used to enable the ac bias generator and also develops, through F1/G3 transistors, the +15 WE and +5 WE supply voltages.

Write current is sensed by the voltage developed across a 10 ohm resistor such that write current -WR CURR is a logic low when write current is flowing through the head coils.

The erase circuit is enabled by ERASE when File Protect and Rewind are not true. F1 transistor turns on allowing erase current to flow through the erase head coil.

A +5V fault detect circuit consists of a differentiator with inputs of +5V and +5VR. Any variance of the +5V input will cause the collector output of Q1 to go from +22V to 0 volts, thus removing the Write Driver supply voltages and shutting down the write current.

Figure 4-19. WRITE CONTROL BLOCK DIAGRAM

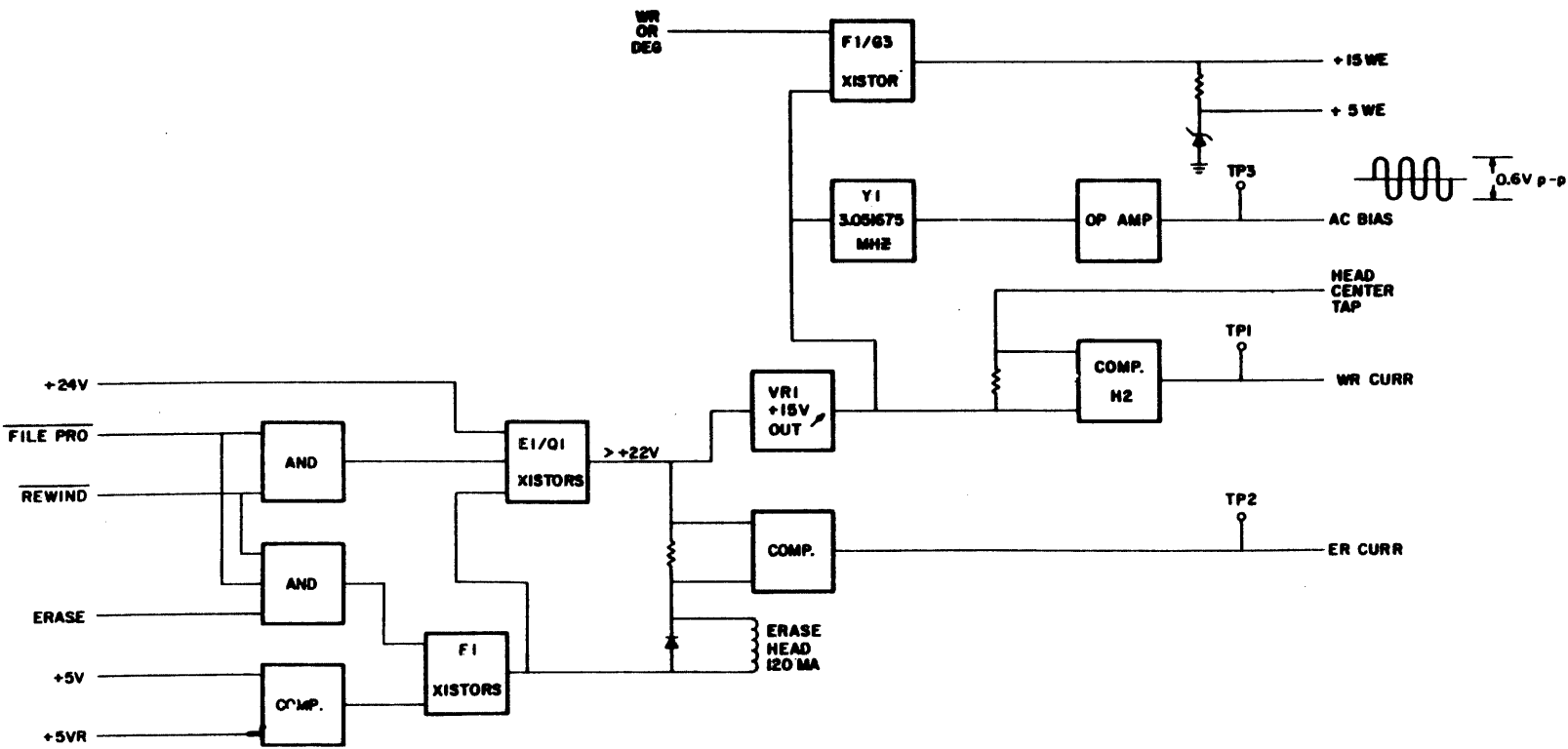

4.7.2 Write Driver LSI

The Write Driver is an LSI circuit designed to output a write current with a "step" and ac bias. The waveform shown in the Write Driver block diagram (Figure 4-20) is the summation of AC bias current, step current, and write current. The transistors used on the Drive 1 and 2 outputs of the LSI are voltage amplifiers used to amplify the relatively low voltage drive outputs to the write head coils.

The Data Pulse output of the LSI is used to trigger an external timing circuit. The output pulse width of timer B4 is dependent on the resistor selection through a multiplexer which is gated by high or low speed and PE or GCR operating modes. The output pulse determines the write compensation times for the write driver.

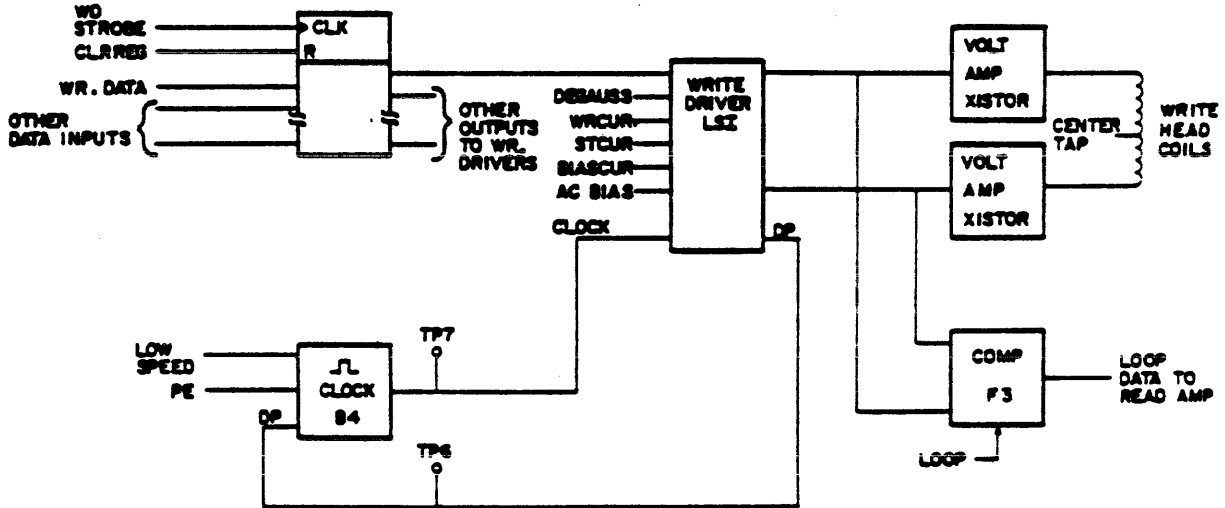

Figure 4-20. WRITE DRIVER BLOCK DIAGRAM

4.7.3 Degauss

During a write operation, current flow through the write head causes residual magnetism to build up around the write coils. If the residual magnetism is not neutralized, partial tape erasure is possible during succeeding tape operations.

In order to prevent this unwanted magnetism, the transport performs a degauss operation (Figure 4-21) at the conclusion of a write function. When the write enable (-WR EN) signal goes from a logic low to a logic high, the microprocessor refreshes the write reference (+WR REF) signal to its maximum voltage, charging C18 refresh capacitor. The microprocessor then stops the refresh cycle, allowing the refresh degauss capacitor to discharge. The write current operational amplifiers see a decreasing positive voltage, the affect of which results in an exponential decay of write current. At the same time that the capacitor is allowed to discharge, the write data input lines are switched at a 10 KHz rate. As the write current is switched at 10 KHz, the exponential decay of the current waveform causes any residual magnetism to be neutralized.

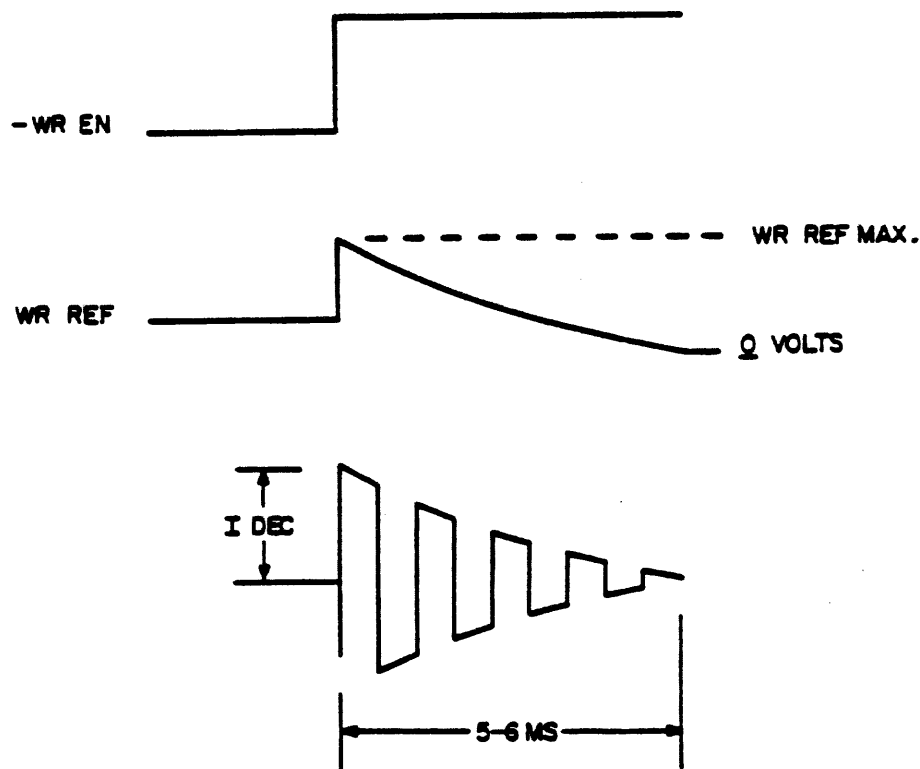

Figure 4-21. DEGAUSS WAVEFORM

4.8 READ AMPLIFIER MODULE

A read operation is initiated from the Interface Controller during any read or write operation. As tape motion is initiated and tape passes across the read head coils, recorded data on the tape induces a voltage in the head coils. This voltage has to be amplified, and circuit selection made, depending on tape speed and recording mode. The entire read chain is responsible for detection of data, amplification of the low amplitude readback signal, and conversion of the analog signal to a digital TTL logic level for use in the formatter and interface portions of the transport. See Figure 4-22.

4.8.1 Read Recovery

As data is detected when tape passes the read head, the induced voltage is differentially coupled to a preamplifier to help reduce common mode noise while amplifying the relatively weak read head signal. The amplification factor at this stage is determined by a programmable gain control circuit that is selected by the microprocessor. The amplified signal is then differentially coupled to a second stage for an additional gain of 20.

The third stage in the read chain is a selectable gain, low pass filter providing roll-off of the high and low end of the read signal. Gain of this stage is dependent on the speed and recording mode that the microprocessor selects.

The fourth stage is both a programmable bandpass filter and differentiator. The bandpass filter, with a frequency selected by the speed and recording mode, sets the upper and lower frequency limits of the input signal.

The fourth stage output is connected to both the zero cross detector and envelope threshold level detector. The threshold circuit compares the single-ended output voltage of the fourth stage with a clip level voltage labeled TH1 and TH2. The clip levels are a percentage of the nominal input voltage and are predetermined by the microprocessor, depending on the type of operation being performed. The threshold detector turns on with a delay of approximately 6.8 microseconds in high speed (75 ips) or 27 microseconds in low speed (25 ips), and turns off with a delay of approximately 12.3 microseconds in high speed or 48 microseconds in low speed. Envelope detection takes place only when the processed read signal overcomes the microprocessor-controlled clip levels. This microprocessor-controlled level can be between 0 and 100% of the read signal.

Output from the envelope detection/clip circuits is ANDed with the output of the zero cross detector to enable the transfer of read data from the read amplifier board.

Figure 4-22. READ AMPLIFIER BLOCK DIAGRAM

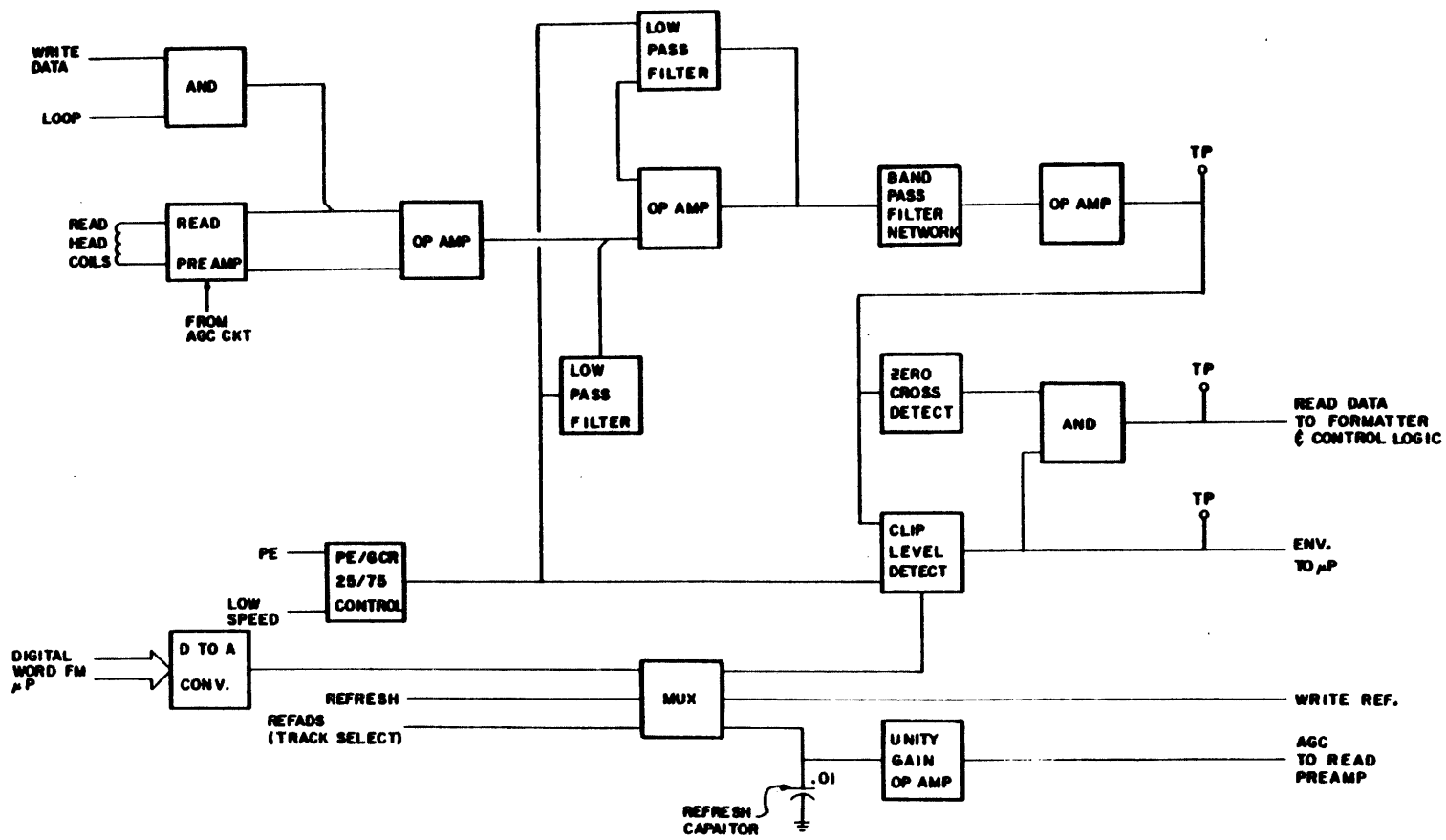

4.8.2 Automatic Gain Control (AGC)

AGC is designed to replace the potentiometer that would normally be used to determine the readback amplitude of recorded data.

In PE mode, the circuit is activated through the use of field service diagnostics when the PC board or magnetic head is replaced, or if reported errors are such that the field service determines the need to activate AGC. In the GCR mode, the circuit is activated every time tape is read from the BOT marker. When the formatter recognizes the GCR ID burst, the AGC circuit is enabled so that the first stage amplifier gains can be set during the ARA burst.

The AGC lines during normal operation are constant, and provide the appropriate input to the first stage amplifiers to set a nominal output of 2.0 volts peak-to-peak at the analog test point. This output voltage may vary slightly due to magnetic head wear or the type of magnetic tape being used.

Operation of the AGC circuit during the off-line field service diagnostics in PE or during the ARA burst in GCR is as follows: The readback signals are sampled through the ENV outputs of the read chain, with an AGC clip level set at 95%. The test is initiated with a binary bit count of 128 (80 Hex) applied to the Digital-to-Analog Converter (DAC). The output voltage of DAC is then applied to an analog multiplexer. The microprocessor provides the input gating to the multiplexer so that the voltage conversion of the 128 count is applied to each of the nine read circuits on an individual basis.

Using one read channel for discussion purposes, AGC voltages are set up as follows: The voltage equivalent of the binary 128 count is gated through the analog multiplexer and charges a 0.01 uF capacitor to the value whereby, the read amplifiers have a mid-point gain. As data is read from tape, the output of the read amplifier is sampled by the envelope comparator. If the ENV signal is low, the microprocessor uses a successive approximation method of the binary count to the DAC so that an optimum AGC voltage is applied to the read amplifiers. If the ENV signal is low or inactive, the microprocessor lowers the binary count by half (64) to the DAC. The DAC then outputs a voltage equivalent to the 64 count to the AGC capacitors. The read amplifier gain is increased and the ENV signal is again sampled by the microprocessor. The microprocessor adjusts the binary count either up or down by half of the previous count, depending on whether the ENV signal is active or inactive. This method of successive approximation is continued until the microprocessor determines, via the ENV signal, that the read gain is optimum. In this manner, the count "zeros in" on the point at which the ENV signal is active except for extraneous pulses going inactive. At this point, it can be assumed that, if the ENV signal is mostly active at the 95% AGC clip level, then when the normal clip level is used, then ENV signal will be a solid active level.

The binary count for each read channel is stored in memory. During normal on-line operation, the microprocessor will access memory every 11 milliseconds, and the AGC voltage charges the 0.01 uF refresher capacitor to maintain a constant gain of the first stage read amplifier.

4.8.3 Loop Data

The LOOP signal is used to exercise the read/write circuits without tape motion. In the read circuits, the signal LOOP turns on a transistor and FET circuit so that the read chain is effectively isolated from the read preamplifier and magnetic head. This isolation allows the loop write data to be connected to the read chain for diagnostic purposes.

4.9 FORMATTER MODULES

The Formatter Modules, comprising the Formatter Read Module and the Formatter Write Module, are located functionally between the Interface Controller Module and the Read/Write/Servo Control logic set. The Formatter Modules perform the following operations:

1. Translate I/O commands sent from the host system for the tape drive.
2. Encode and decode data to and from PE format or GCR format.
3. In write operations, generate tape control and identification marks. In read operations, delete tape control and identification marks.
4. Generate and monitor data error detection codes and perform error correction "on-the-fly".
5. Monitor and report Hard Error (HER) conditions.
6. Control re-instruct times when in streaming operation.

4.9.1 I/O Command Translation

The Formatter Modules serve as a link in the I/O chain by accepting commands sent by the host system, and translating these commands into tape motion and data transfer instructions for the tape drive (see Figure 4-23).

4.9.2 Data Conversion

The Formatter Modules are responsible for encoding and decoding data to and from PE format and GCR format.

Figure 4-23. I/O COMMAND TRANSLATION

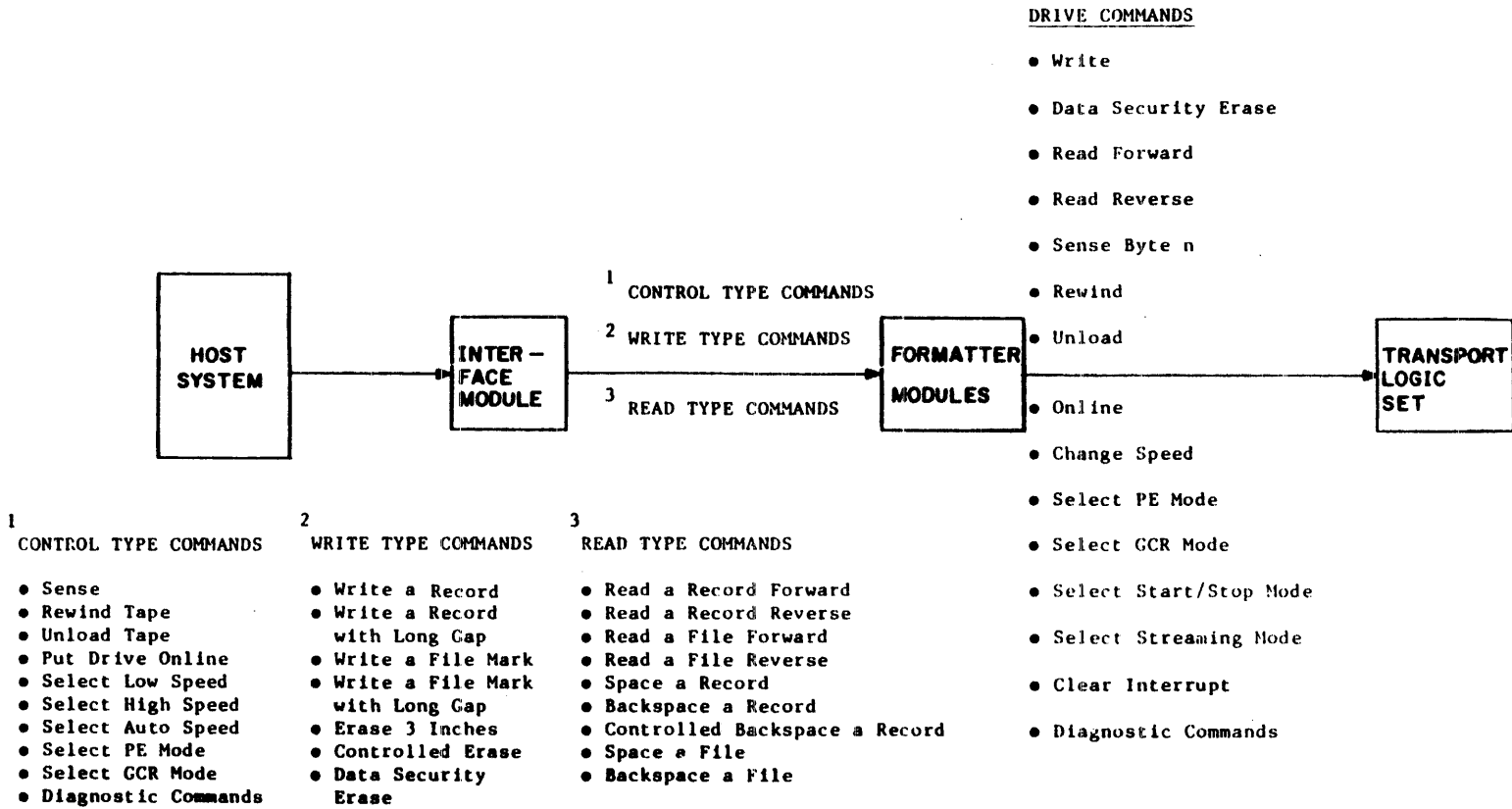

4.9.2.1 PE Data Conversion - In PE format, the data block must begin with a preamble and end with a postamble. In the data format sent by the host system, flux transitions in the middle of a cell define the 1's and 0's. A positive pulse (flux transition) indicates a 1; a negative pulse indicates a 0. A cell is the time required to transfer one data bit (see Figure 4-24). In order to denote two contiguous 1's or 0's, a phase pulse must occur at the junction of the two cells. A positive phase pulse occurs at the junction when both cells contain 0; a negative phase pulse occurs when both cells contain 1. The absence of a phase pulse at a cell junction indicates that the cells contain opposite values.

4.9.2.2 GCR Data Conversion - GCR (Group Coded Recording) is a coding scheme rather than a recording mode. The GCR scheme translates an 8-byte data group, comprising two 4-byte subgroups, into a 10-byte recording group, comprising two 5-byte subgroups. The first data subgroup converted contains 4 data bytes; the second data subgroup converted contains 3 data bytes and an Error Correcting Code (ECC) (see Figure 4-25). Note that in the 5-bit GCR conversion of the 4 data bits, there are no more than two contiguous 0's and no more than a single 0 at either end of the 5-bit string (see Figure 4-26). This scheme yields a more narrow band-width and better synchronization capability.

After conversion to the GCR code, the data is recorded on tape using the NRZI method. In the NRZI method, a change in the direction of flux indicates a 1 bit (see Figure 4-27).

4.9.3 Tape Control and Identifier Mark Generation and Deletion

For both PE and GCR modes, the Formatter Modules generate the tape control and identifier marks in write operation, and strip off these marks during the read operation. The following paragraphs detail the content and location of these marks.

4.9.3.1 PE Data Block Format - The PE tape (see Figure 4-28) begins with the PE density identification burst consisting of a series of alternate 1's and 0's in track 4. The inter-block gap, which follows the density identification burst, is nominally 0.6 inch, but may be increased up to 1.2 inches, depending on data availability.

The PE data block begins with a preamble (40 tracks with all 0's followed by 1 track of all 1's) and ends with a postamble (1 track of all 1's followed by 40 tracks of all 0's).

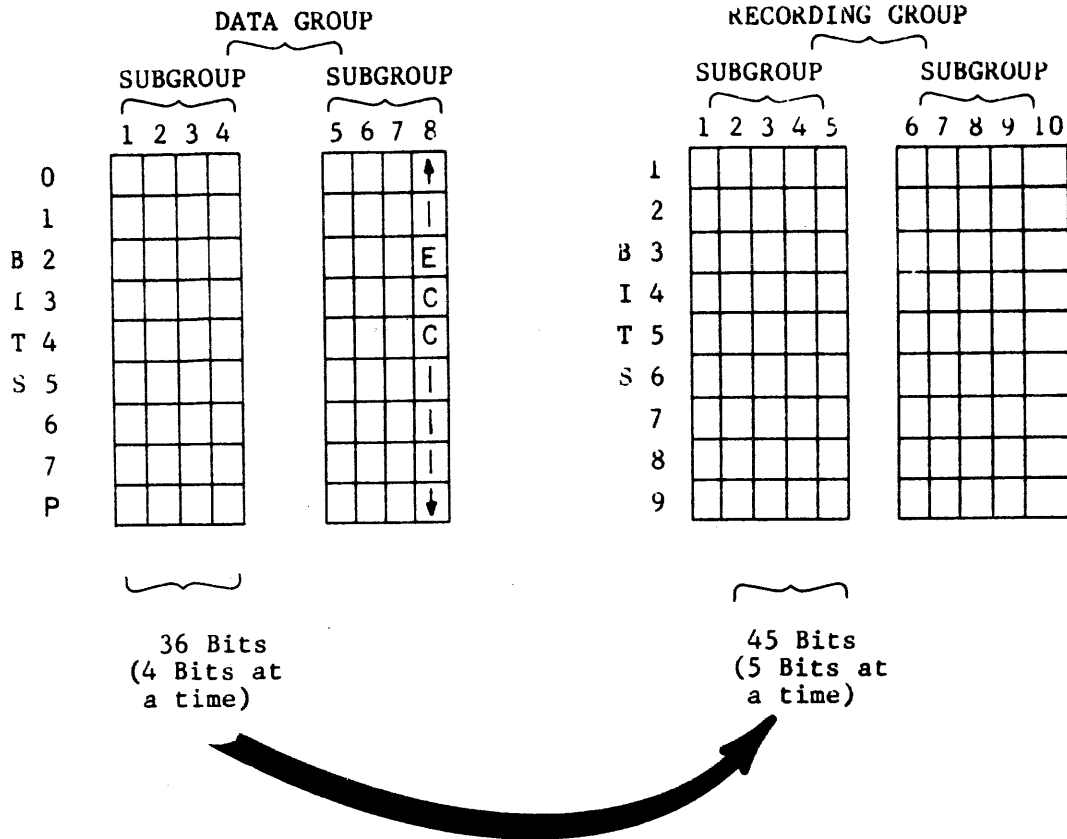

Figure 4-25. GCR CONVERSION

4 Bits Data Value	⇒	GCR Value
0 0 0 0		1 1 0 0 1
0 0 0 1		1 1 0 1 1
0 0 1 0		1 0 0 1 0
0 0 1 1		1 0 0 1 1
0 1 0 0		1 1 1 0 1
0 1 0 1		1 0 1 0 1
0 1 1 0		1 0 1 1 0
0 1 1 1		1 0 1 1 1
1 0 0 0		1 1 0 1 0
1 0 0 1		0 1 0 0 1
1 0 1 0		0 1 0 1 0
1 0 1 1		0 1 0 1 1
1 1 0 0		1 1 1 1 0
1 1 0 1		0 1 1 0 1
1 1 1 0		0 1 1 1 0
1 1 1 1		0 1 1 1 1

Figure 4-26. GCR TRANSLATION VALUES

4.9.3.2 GCR Data Block Format - The GCR data format requires not only preamble and postamble patterns, but also data conversion into groups, for each of which an Error Correcting Code (ECC) clearance is generated. Also, Cyclic Redundancy Checks (CRC's) and Auxiliary Cyclic Redundancy Checks (ACRC's) are added to the data to facilitate detection and correction of errors. Resynchronizing bursts are added for transfers over 1106 bytes to enable the read detection logic to resynchronize (see Figure 4-29).

The following describes GCR tape format components in the order they are written on tape.

- o Density Identification - A burst in the PE frequency range on track 6. All other tracks are erased.
- o Interblock Gap (IBG) - A dc erased section of tape separating blocks of information. Gap length is set by W1 jumper on the Formatter Write module. W1 is factory set for variable long gap (0.6 to 1.2 in). This setting is used for normal operation on VAX systems.
- o ARA (Automatic Read Amplifier) Burst - A string of all 1's in all tracks placed on the tape for the purpose of setting up the read amplifiers.
- o ARA ID (Automatic Read Amplifier Identification) - A special control at the end of the ARA. When reading backwards, the ARA ID denotes the appearance of the ARA burst.
- o PREAMBLE (see Figure 4-30A) - A group of signals recorded at the beginning of a block for circuit synchronization. The preamble contains 16 subgroups, the first of which is the Terminator (TERM) control subgroup. The terminator subgroup is the first (and last) subgroup of a record. The next subgroup is the Secondary (SEC) control subgroup which is the second (and next to last) subgroup of a record. Next, 14 synchronization subgroups are written which complete the preamble.
- o MARK 1 - A control signal which separates control subgroups from data. When the tape is moving forward, it denotes the beginning of data.
- o Data Group - From 1 to 158 data groups may be written. Each data group comprises two subgroups. The first contains four data bytes. The second subgroup contains three data bytes and one Error Correcting Code (ECC) byte. Note that the tape format is shown before the 4/5 conversion takes place.

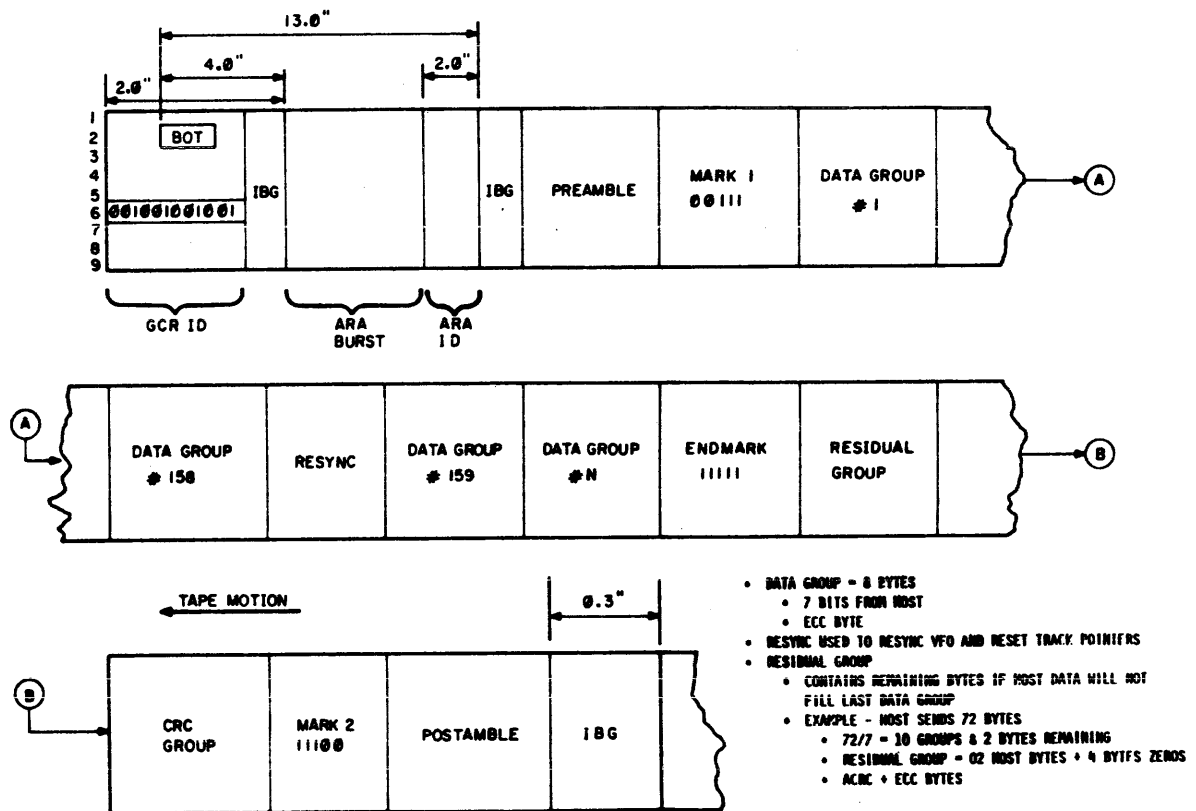

Figure 4-29. GCR TAPE FORMAT

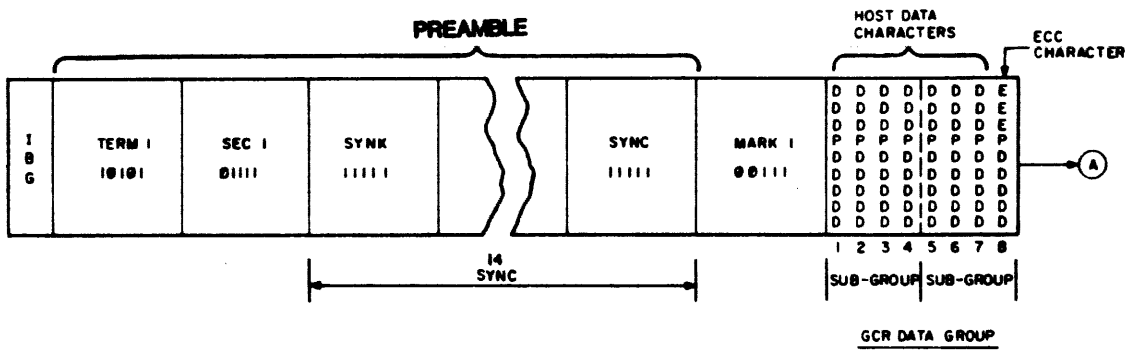

Figure 4-30A. DETAIL OF GCR TAPE FORMAT

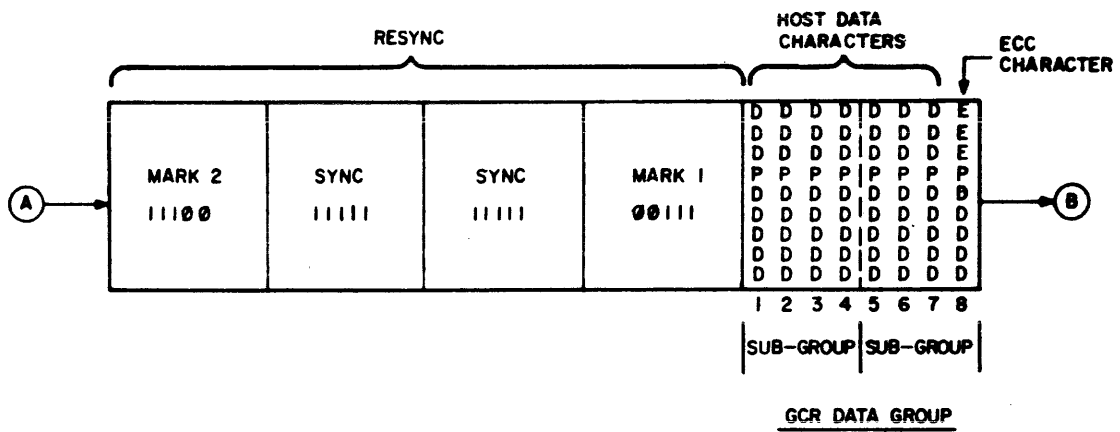

Figure 4-30B. DETAIL OF GCR TAPE FORMAT

- o RESYNC (See Figure 4-30B) - The RESYNC burst is written following the 158th data group in order to resynchronize the circuits and to clear dead-track and phase error pointers. The first element of the RESYNC burst is MARK 2, a signal which separates data from control subgroups. Next, two sync subgroups are written, followed by MARK 1, to separate the control signals from the data. After RESYNC, another series of data groups may be written.
- o END MARK (see Figure 4-30C) - A control signal separating the last full data group from the residual group.
- o Residual Group (see Figure 4-30C) - Contains the remaining data characters from the host, and pad characters if needed, to fill the first six positions in the group. The 7th character is the Auxiliary Cyclic Redundancy Check (ACRC); the 8th character is the Error Correcting Code (ECC) character.
- o Cyclic Redundancy Check (CRC) Group (see Figure 4-30C) - The first character is either a pad character or the CRC character. Positions 2 through 6 are occupied by the CRC character. The 7th position is occupied by the residual character and the 8th position is occupied by the ECC character.
- o MARK 2 (see Figure 4-30C) - A control signal separating data from control subgroups. When tape is moving forward, it marks the beginning of other control signals.
- o POSTAMBLE (see Figure 4-30D) - A group of control signals at the end of the data block. There are 16 subgroups, the first 14 of which are synchronizing subgroups for the electronic synchronization of the circuits. The next to last subgroup is the Secondary (SEC) control subgroup and the last is the Terminator (TERM) control subgroup.

Under control of the Formatter logic, the preamble, postamble and resynchronizing codes are generated in the correct sequence, and the data is manipulated to produce a correctly coded data block. After the preamble is generated, data from the Interface Module is clocked through the Formatter input circuitry to the 4/5 Converter where 4 bytes are converted to 5 bytes. After every seventh byte, an ECC character is generated by the logic from the incoming data and sent to the 4/5 Converter. At the end of data transfer, with the Last Word signal from the Interface Module, padding characters of zero value are added to the final group to make a complete group. Cyclic Redundancy Check (CRC) and Auxiliary Cyclic Check (ACRC) characters are generated from the incoming data and inserted in the data block in the appropriate locations. At the termination of data transfer, a postamble is generated and placed at the end of the data block (see Figures 4-30A, 4-30B, 4-30C, and 4-30D).

During a read operation, the control and error detection codes are removed in the Formatter Modules before the data is transferred to the host.

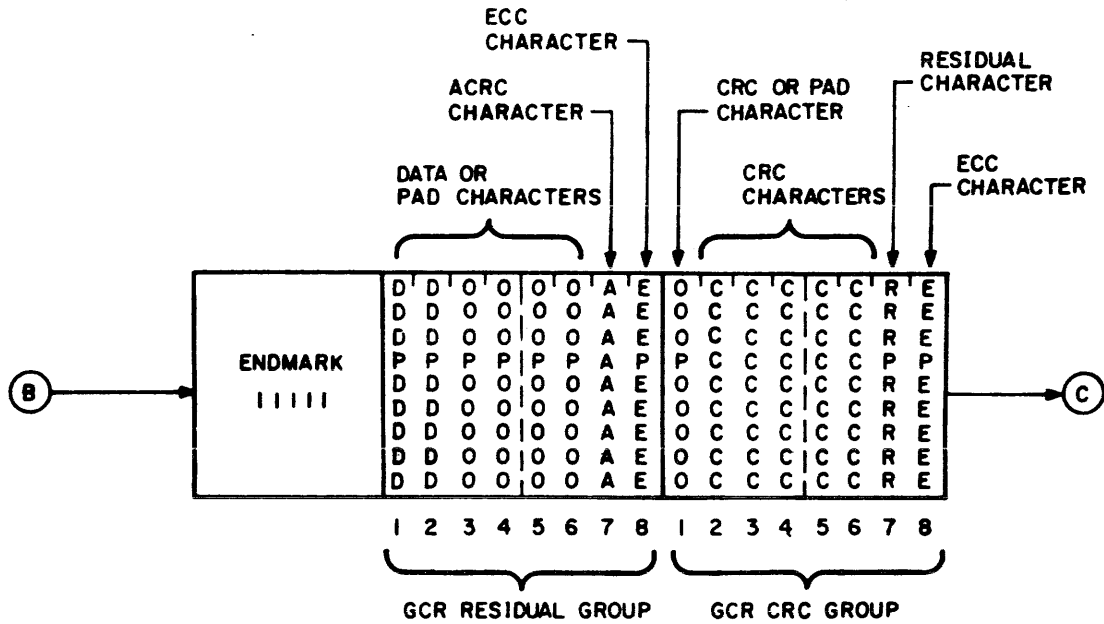

Figure 4-30C. DETAIL OF GCR TAPE FORMAT

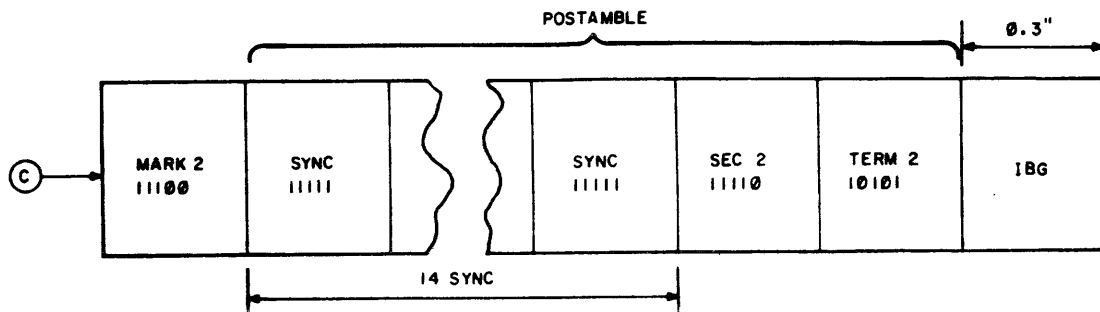

Figure 4-30D. DETAIL OF GCR TAPE FORMAT

4.9.4 Error Detection and Correction

When operating in PE mode, single track, "on-the-fly" parity error detection and correction is performed. In GCR mode, single and 2-track, "on-the-fly" error detection and correction are performed by means of cyclic codes. Both the PE and GCR methods are described in this subsection.

The read detection circuit performs best when the incoming signal level from the track is between 300 mV and 900 mV; the optimum level is 500 mV. When the signal level drops below a specified value, a warning latch is set for that track to denote the presence of a marginal signal. The latch remains set until resynchronization or the end of the data block. Setting the latch is called "dead tracking".

4.9.4.1 PE Mode - In PE mode, when a parity error is found in a byte, the warning latches for all 9 tracks are checked to see if any track is "dead tracked". If a track is, it is assumed that the bit in the dead track is in error, and that bit is reversed before the byte is sent to the Interface Controller Module.

For proper data detection in PE mode, the flux reversal denoting a bit should occur approximately in the middle of the bit cell. If the flux reversal takes place outside a window of $\pm 25\%$ of center (see Figure 4-31), a phase error signal is generated to indicate that the data detected on that track may be in error. In GCR mode, the limit of the window in a write operation is $\pm 37.5\%$ of center; in the read operation, the window limit is $\pm 43.75\%$ of center (see Figure 4-32). The phase error indication lasts only as long as the time required for the bit cell to traverse the read head. The data correction is similar to that described in dead tracking - when a parity error is found, the phase error field is scanned to see if a track is reported in error; if so, the bit in that track is reversed.

The limitations to the PE methods are that, if more than 1 track is dead tracked, or if a dead track error and phase error occur in the same byte, an unresolved bit error condition exists. Also, parity checking does not detect an error if both bits are wrong. Or, if only one bit is wrong, there is no way to determine which of the two tracks is in error.

The lack of perfect perpendicularity between the tape track and the read/write heads is known as "skew". This condition causes the bits comprising a byte to be read at slightly different times.

Skew compensation is implemented by transferring read data from the tape over nine separate detection circuits (one for each track). The detected bits are gated independently into a skew buffer. When the skew buffer has received all of the bits in the byte, the byte is gated out as a unit.

4.9.4.2 GCR Mode - In GCR mode, three check characters based on cyclic codes are used in error detection and reporting. These check characters are:

- o Error and Correcting Code (ECC) Character
- o Cyclic Redundancy Check Character (CRC)
- o Auxiliary Cyclic Redundancy Check Character (AUX CRC)

The ECC character, which contains 8 bits, is generated as the 8th byte of a data group (see Figure 4-25). By means of the ECC character, single track errors can be detected and corrected "on-the-fly" without the need of track pointers. The ECC character also detects double track errors, but requires the aid of dead track pointers and phase error pointers to correct the errors. These pointers use the same methods to identify the tracks as in PE error detection.

The CRC character and AUX CRC character are generated from the data structure and written into it so that the validity of the data can be checked after it is read. These characters indicate only the occurrence of one or more errors; they do not identify the location of the error(s), nor are the error(s) corrected. However, the host system is informed of the error occurrence so that the host can initiate its retry procedure.

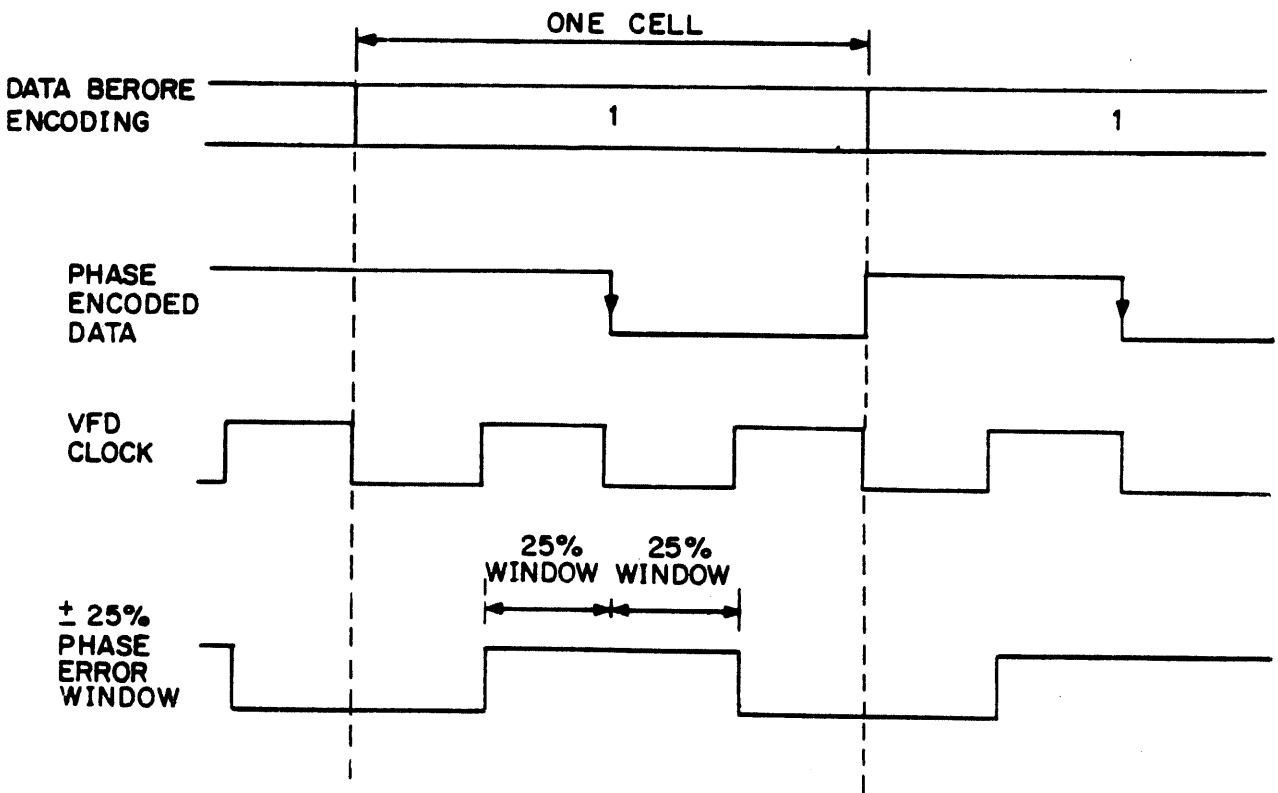

NOTE: Phase error is generated when no data transition within $\pm 25\%$ window.

Figure 4-31. PHASE ERROR WINDOW - PE MODE

Figure 4-32. PHASE ERROR WINDOW - GCR MODE

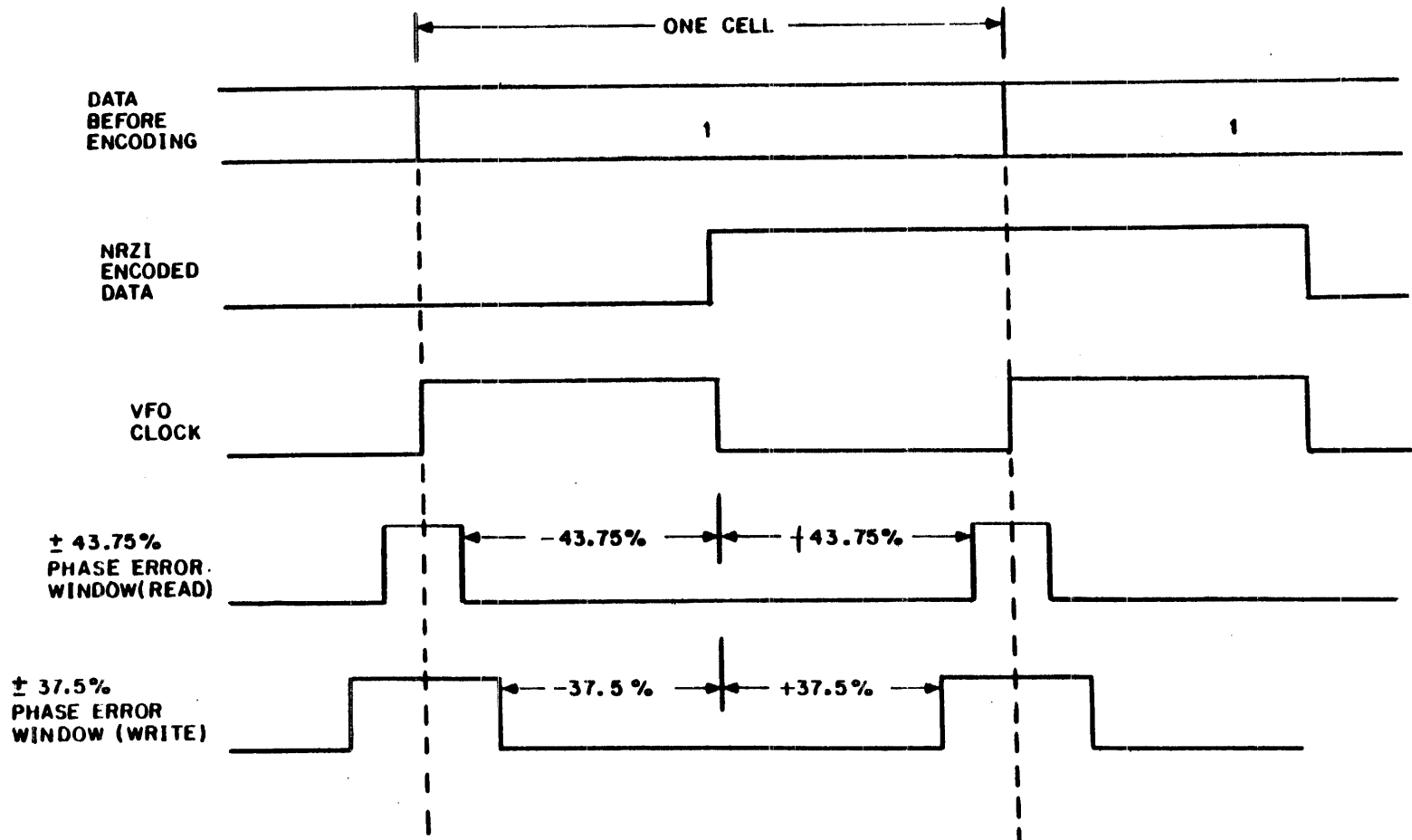

4.10 INTERFACE CONTROLLER MODULES

Each design version of the transport (TU81 or TA81) has its unique Interface Module. The Interface Module of the TU81, which is a single-host device, is the Tape Mass Storage Control Protocol (TMSCP) Module; the Interface Module of the TA81, which is a dual-host device, is the Standard Tape Interconnection (STI) Module (see Figure 4-33). The basic functions of both Interface Modules are the same: to translate commands from the host(s) into a form usable by the Formatter Modules, to transfer status information from the Formatter Modules to the host, and to oversee execution of read/write operations.

4.10.1 TMSCP Interface Controller Module

The commands from the host are transferred from the host to the TMSCP Module through the M8739 UNIBUS Adapter Module (see Figure 4-33). A functional description of the TMSCP Module and the M8739 UNIBUS Adapter in the TU81 Subsystem is contained in Appendix A.

The interface lines between the TMSCP Module and Formatter Modules are shown in Figure 4-34. The function and mnemonic of each signal line or set of lines are given below. The first letter (F) of the mnemonic denotes a Formatter signal.

<u>SIGNAL</u>	<u>FUNCTION</u>
COMMAND STROBE (FCSTR)	To strobe the 8-bit coded command contained on WRITE DATA lines into the Formatter. The Formatter commands are listed in Table 1.
COMMAND BUSY command (FCBY)	Signals the TMSCP module that the command has been accepted. The COMMAND BUSY signal sets within 100 nsec from the trailing edge of the FCSTR signal. The FCBY signal remains true until operation is completed. Once the FCBY signal goes false, a new command can be issued. Any commands issued while FCBY is true are discarded.
DATA BUSY (FDBY)	Goes true only when the transport has reached operating speed, traversed the IBG, and the Formatter is about to write data on tape or read data from tape. DATA BUSY remains true until the data transfer is finished. FDBY also goes true during Sense, Spacing, and Erase operations.

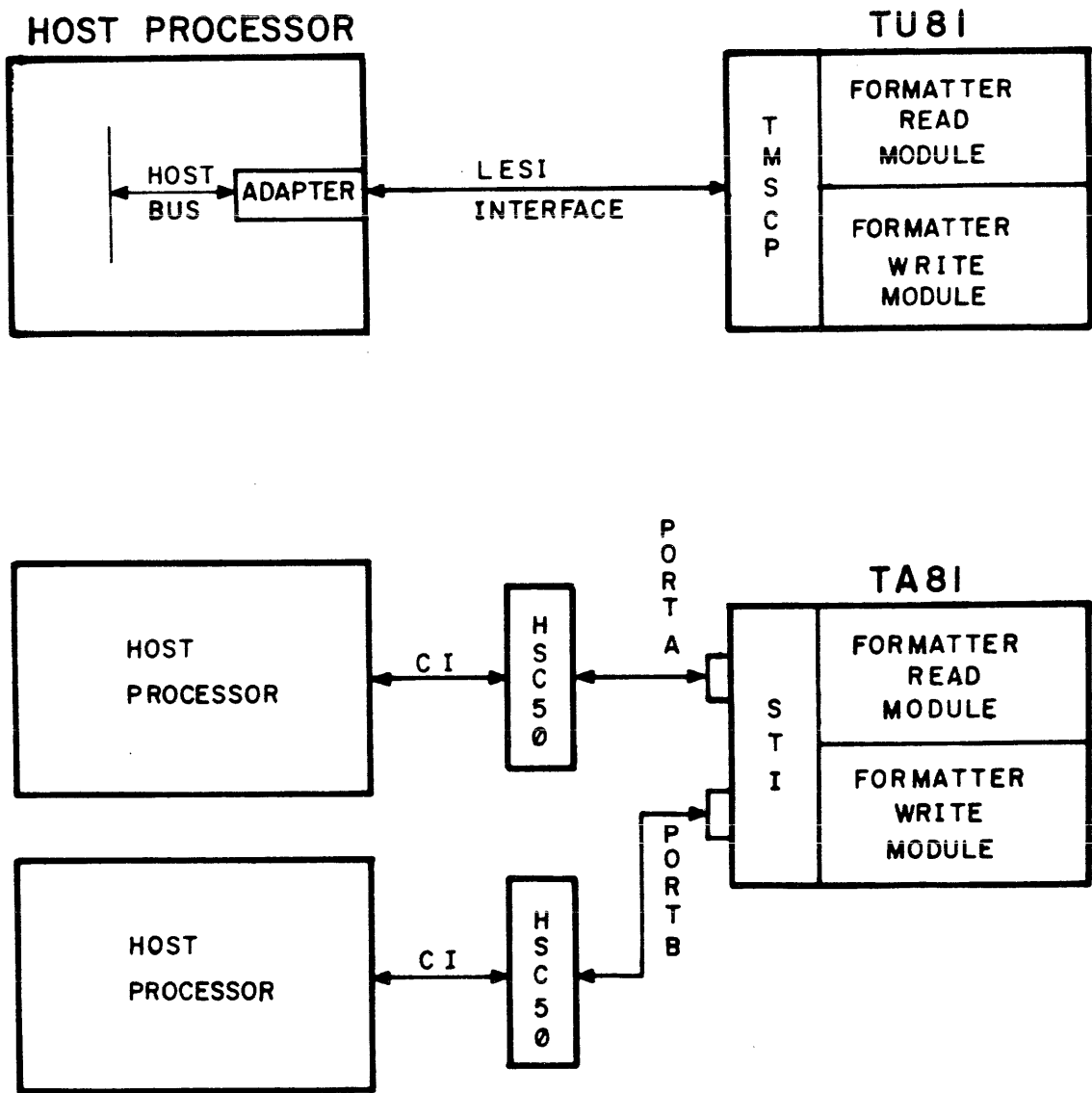

Figure 4-33. BLOCK DIAGRAM, HOST/TRANSPORT INTERFACE

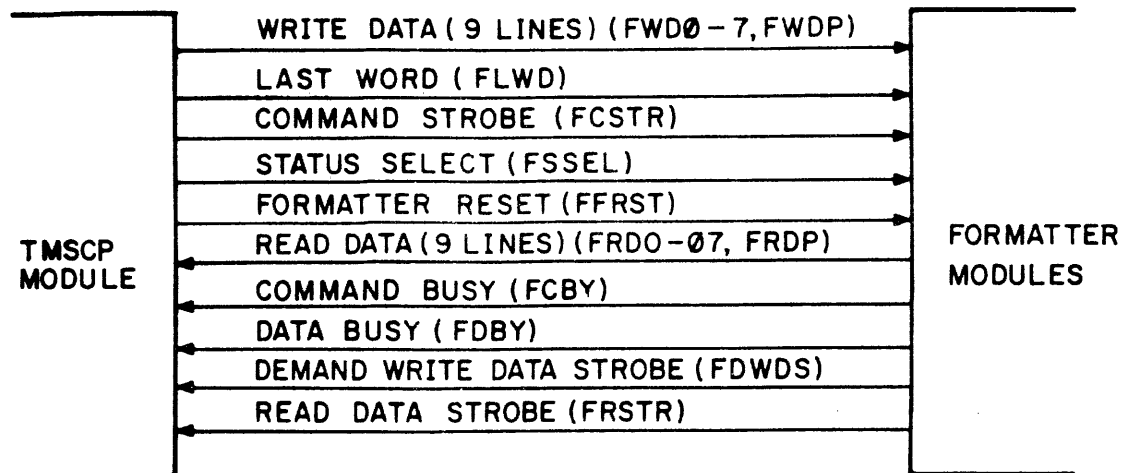

Figure 4-34. TMSCP/FORMATTER INTERFACE

<u>SIGNAL</u>	<u>FUNCTION</u>
FORMATTER RESET (FFRST)	When true, causes initialization of the Formatter. The FORMATTER RESET signal should be issued only during power-up of the TMSCP Interface Module or when a runaway condition is detected. All other times, the Formatter should be enabled.
STATUS SELECT (FSSEL)	Once the COMMAND BUSY signal goes false, the Formatter and Drive status can be examined on the READ DATA lines. The STATUS SELECT line, when true, selects the Device status byte, and when false, selects the Formatter status byte. The status information represents the status for the operation just completed. The status can be read only when FCBY is false. When FCBY is true, read data is selected on the READ DATA lines.
LAST WORD (FLWD)	During Write operations and Controlled Space operations, this line, when true with FWD0-7 and FWDP, indicates that the character being strobed into the Formatter is the last byte of the record. During a Controlled Space operation, the contents of the WRITE DATA lines are ignored.

SIGNAL

FUNCTION

DEMAND WRITE DATA
STROBE (FDWDS)

Comprises a pulse for each data character to be written onto tape. During a Controlled Space operation, this line is also used. However, no data is transferred or written on tape. The TMSCP may use this line to determine the length of tape which is to be spaced. During Write File Mark and Erase operations, this signal is not used since the Formatter controls these operations internally.

READ DATA STROBE
(FRSTR)

Comprises a pulse for each character of read information to be transmitted to the Adapter Interface and is used to sample READ DATA lines FRD0-7 and FRDP.

WRITE DATA (9 lines)
(FWDO-7, FWDP)

Used to transmit write data and commands to the Formatter. FWDO is the most significant bit.

READ DATA (9 lines)
(FRD0-7, FRDP)

Used to transmit read data from the Formatter to the TMSCP Interface Module. FRD0 is the most significant bit. Sense data is also transmitted on these lines.

4.10.1.1 Commands - The commands transferred from the TMSCP Interface Module to the Formatter Modules are described below with the hex code for each command.

HEX
CODE

COMMAND

FUNCTION

80

READ FORWARD

Causes the tape to be accelerated to operating speed. The transport reads the next logical record of data encountered.

If the transport has not detected data within 25 feet of tape motion for PE or 15 feet for GCR, it terminates operation by decelerating tape and resetting FORMATTER BUSY status. An error condition is set as a result of the time-out. File Mark testing is performed during a Read operation.

<u>HEX CODE</u>	<u>COMMAND</u>	<u>FUNCTION</u>
80	READ FORWARD (Cont'd)	<p>In Start/Stop mode, the transport decelerates tape after each block. The next command is not executed until the stop is completed.</p> <p>In Streaming mode, if the next READ command is received during the Reinstruct Time, the transport continues tape motion and reads the next block of data. Otherwise, the transport decelerates tape. If the READ command is received after the Reinstruct Time, the command is not executed until the recovery cycle is completed.</p>
01	READ REVERSE	<p>READ REVERSE is not supported in either PE mode or GCR mode. The operation is, however, simulated in the following way:</p> <ul style="list-style-type: none"> - A SPACE REVERSE is performed followed by a READ FORWARD to establish record length for Host memory address calculation. - A second SPACE REVERSE is performed followed by a READ FORWARD to transfer data to the Host. - A third SPACE REVERSE is performed to position the tape as if a READ REVERSE operation had taken place.
02	READ FILE FORWARD	Similar to READ FORWARD, except that the next logical file is read.
83	READ FILE REVERSE	Similar to READ REVERSE, except that the preceding file is read.
04	READ FORWARD WITH HIGH THRESHOLD (PE Only)	Performed in the same manner as READ FORWARD except that clip level is at a higher value. This command is used in error recovery after normal read has been exhausted.

<u>HEX CODE</u>	<u>COMMAND</u>	<u>FUNCTION</u>
08	SPACE FORWARD	This operation is similar to a READ FORWARD, except that no READ STROBE signals are generated and no read data is supplied to the controller. Error checking is not performed on the read data. However, File Mark testing is performed.
89	SPACE REVERSE	This operation is similar to SPACE FORWARD, except that the transport moves tape in the reverse direction.
8A	SPACE FILE	Similar to SPACE FORWARD, except that the tape is moved forward to the next file.
0B	BACKSPACE FILE	Causes backspacing continuously until a file mark is detected. If BOT is encountered while backspacing, the command is terminated with a hard error condition set. This condition should not occur normally.
8C	CONTROLLED SPACE FORWARD	Causes the transport to accelerate tape in the forward direction and to start issuing DEMAND WRITE DATA STROBES. There are restrictions on maximum space length. DEMAND WRITE DATA STROBES continue at the data rate until the LAST WORD command is given from the controller. Tape motion continues until an IBG is detected. This terminates the operation. No read data is sent to the controller and no error checking is performed. File Mark testing is not performed for this operation. This operation is similar to a Write operation except that no data is recorded on tape.
0D	CONTROLLED SPACE REVERSE	This operation is similar to the CONTROLLED SPACE FORWARD, except that tape motion is in the reverse direction.

<u>HEX CODE</u>	<u>COMMAND</u>	<u>FUNCTION</u>
10	WRITE	<p>Causes the transport to accelerate tape and start transferring data. Data transfer continues until the LAST WORD command is given from controller. The transport continues to move tape to perform the Read-After-Write check.</p> <p>In Start/Stop mode, the transport decelerates tape after each block. The next command is not executed until the transport has completed its stop.</p> <p>In Streaming mode, if the following WRITE command is received during Reinstruct Time, the transport continues tape motion and writes next block. Otherwise, the transport decelerates tape. If a WRITE command is received after Reinstruct Time, the command is not executed until the transport has completed its Recovery cycle.</p>
98	WRITE WITH LONG GAP	Causes the transport to be set for Long Gap regardless of mode and speed settings.
92	WRITE FILE MARK	Causes the transport to start tape and Write File Mark pattern on tape.
1A	WRITE FILE MARK WITH LONG GAP	Causes the transport to start tape and Write File Mark pattern with Long Gap on tape.
94	ERASE GAP	Causes the IBG to be extended by 3 inches. The ID burst is written when an ERASE command is given with the tape positioned at BOT.
1C	ERASE GAP WITH LONG GAP	Causes erasure of 3 inches of tape not including IBG. Reinstruct time and gap following the record are extended by an additional IBG.

<u>HEX CODE</u>	<u>COMMAND</u>	<u>FUNCTION</u>
16	CONTROLLED ERASE (PE Only)	Causes the transport to accelerate and erase tape continuously until a LAST WORD signal from the controller is set true. This terminates the ERASE operation. The ID burst is written when an Erase command is given with tape positioned at BOT.
9E	CONTROLLED ERASE WITH LONG GAP	Causes erasure of a length of tape specified by TMSCP module. Once tape is up to speed, the formatter starts issuing demand write data strobes as though a write operation is being performed. However, no data is ignored. This process continues until LAST WORD is detected by formatter. Erase operation terminates at that point and an IBG is generated. The length of tape to be erased can be determined by the density: PE = 1600 BPI and GCR = 6250 BPI. For example, in GCR, a 6250 byte record would erase 1 inch of tape not including the IBG.
97	DATA SECURITY ERASE	Causes the transport to erase tape at 75 ips from its position when the command is issued to a position approximately 10 feet past the End of Tape marker. The ID burst is written when the command is issued with the tape positioned at BOT.
20	SENSE	Can be used by TMSCP Module to determine reason for a specific error that occurred during previous operation. A Sense command causes formatter to send sense byte information. DATA BUSY is set true prior to sending sense data. Sense data is sent along with a read data strobe. The period of the read strobe is in the order of 250 microseconds. Each data byte should be examined using leading edge of read strobe. DATA BUSY is reset once all sense data has been transferred.

<u>HEX CODE</u>	<u>COMMAND</u>	<u>FUNCTION</u>
23	ONLINE	Causes the transport to go on-line if tape is loaded.
A4	LOAD	Causes the transport to load tape, if a tape is threaded.
A1	REWIND	Causes the transport to rewind the tape to BOT. In PE mode, the tape unit defaults to Start/Stop mode after Rewind. The command is ignored if unit is already at BOT.
A2	UNLOAD	Causes the transport to unload tape.
B9	FORMATTER HEALTH CHECK	This is a diagnostic command used to test the formatter modules.
BA	FORMATTER LOOPBACK	This is a diagnostic command used to loopback the formatter interface for test purposes.
3B	DEVICE INTERFACE LOOPBACK	This is a diagnostic command used to loopback the transport interface for test purposes.
BC	DEVICE READ/WRITE LOOPBACK	This is a diagnostic command used to loopback transport interface WRITE DATA lines to the READ DATA lines. The transport generates a DEMAND WRITE DATA STROBE and loops back write data from the interface to the READ DATA lines until LAST WORD signal is received. The FORMATTER BUSY and DATA BUSY signals are reset when the last data byte is transmitted. The data transfer rate is at the previous transport speed.
3D	DIAGNOSTIC TEST	Causes execution of diagnostic functions which are resident within the TMSCP storage of transport. Diagnostic Tests pertaining to interface, formatter, and drive elements may be initiated by invoking this command, following the command with a 2-byte data transfer which passes a test number and test option byte to the subsystem. Successful completion of DIAGNOSTIC TEST is indicated by FORMATTER BUSY dropping.

<u>HEX CODE</u>	<u>COMMAND</u>	<u>FUNCTION</u>
3E	DIAGNOSTIC SENSE	Unsuccessful completion of DIAGNOSTIC TEST is indicated by FHER line set. The host then issues a DIAGNOSTIC SENSE command to obtain the Fault Symptom Code byte. The Pathfinder Manual contains additional instructions in the event of a DIAGNOSTIC TEST failure.
BF	DIAGNOSTIC RESPONSE	Used by TMSCP Module on completion of its health check. It uses this command to send to the drive fault code and fault sub-code information.
25	SELECT REMOTE DENSITY	Forces the drive into remote density selection mode. This command will override selection made during power-up. This command should only be issued after drive goes ONLINE.
40	MODE CHANGE	Causes the transport to change Speed mode and/or Density mode of operation. The bit configuration of the command is shown in Figure 4-35.

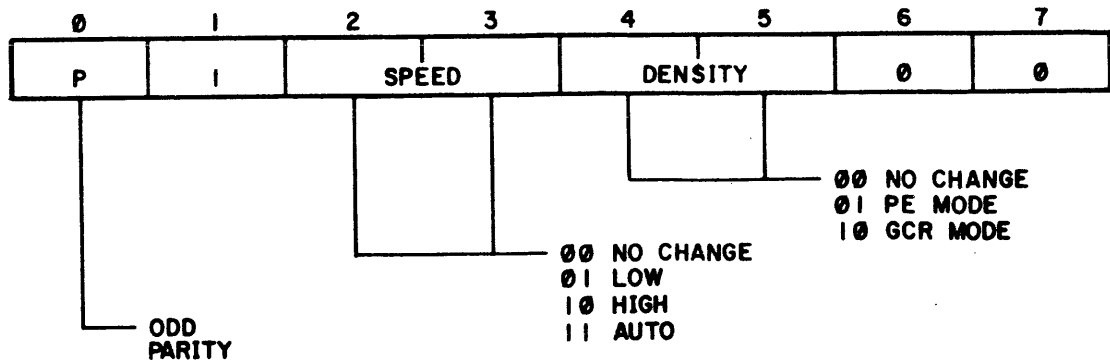

Figure 4-35. MODE CHANGE COMMAND

		<u>MODE CHANGE</u>
<u>BITS 2 & 3</u>	<u>MODE</u>	<u>FUNCTION</u>
01	LOW (Speed)	Causes the transport to operate in the 25 ips mode.
10	HIGH (Speed)	Causes the transport to operate in the 75 ips mode.
11	AUTO (Speed)	Causes the transport to operate in the Adaptive Velocity Gain (AVC) mode, in which the speed yielding optimum throughput is chosen automatically.

		<u>MODE CHANGE</u>
<u>BITS 4 & 5</u>	<u>MODE</u>	<u>FUNCTION</u>
01	PE Mode	Causes the transport to operate in PE mode (1600 bpi density). The dropping of the FORMATTER BUSY line indicates completion of the command. This command is accepted only when tape is positioned at BOT.
10	GCR Mode	Causes the transport to operate in GCR mode (6250 bpi density). The dropping of the FORMATTER BUSY line indicates completion of the command. This command is accepted only when tape is positioned at BOT. The drive executes LOAD operations in PE mode, regardless of the density selected. A prerecorded tape is automatically read at the density at which it was written, even if the incorrect density has been selected. If this condition occurs, the HARD ERROR status bit is set.

4.10.1.2 Status Information - After COMMAND BUSY (FCBY) becomes inactive at the completion of an operation, the status information is placed on the read data lines. When the STATUS SELECT line is false (0), the Formatter status byte is selected. When the STATUS SELECT line is true (1), the Device status byte is selected. The Device status bits indicate the latest state of the device. The bit significance of the status bytes is shown in Figure 4-36.

CMD STATUS		BIT	BIT	BIT	BIT	BIT	BIT	BIT	BIT	BIT	
BUSY	SEL.	0	1	2	3	4	5	6	7	P	
LINE	LINE										
0	0	GCR	HSPD	ASPD	FMK	DIAG	S/S	VLG	VSG		FORMATTER STATUS
0	1	RDY	ONL	RWD	FPT	GPC	HSPD	BOT	EOT		DEVICE STATUS
1	X	READ DATA									

Figure 4-36. READ DATA/STATUS LINE SELECTION

FORMATTER STATUS DEFINITIONS

<u>BIT</u>	<u>MEANING WHEN SET</u>
0 (GCR)	GROUP CODED RECORDING - During the last operation, the formatter was in GCR mode.
1 (HSPD)	HIGH SPEED - During the last operation, the formatter was in High Speed mode.
2 (ASPD)	AUTO SPEED - The speed is selected automatically by the formatter to yield optimum throughput.
3 (FMK)	FILE MARK - A File Mark was detected during the last operation.
4 (DIAG)	DIAGNOSTIC MODE - Set only while running a Diagnostic Test.
5 (S/S)	START/STOP - During the last operation, the formatter was in Start/Stop mode.
6 (VLG)	VARIABLE LONG GAP - During the last operation, the formatter was in Variable Long Gap mode. For a discussion of gap length, refer to paragraph 4.9.3.2.
7 (VSG)	VARIABLE SHORT GAP - During the last operation, the formatter was in Variable Short Gap mode. For a discussion of gap length, refer to paragraph 4.9.3.2.

DEVICE STATUS DEFINITION

<u>BIT</u>	<u>MEANING WHEN SET</u>
0 (RDY)	READY - The transport is ready to accept an external command. This indicates that the initial Load sequence is complete and no Rewind is in progress.
1 (ONL)	ONLINE - The transport is On-line (under remote control). When reset, the transport is under local control.
2 (RWD)	REWINDING - A Rewind operation is in progress.
3 (FPT)	FILE PROTECTED - A reel of tape which has write enable ring removed and is mounted on the transport.
4 (GPC)	GAP CONTROL - The drive is still streaming and Reconstruct Time has not expired. When reset, indicates that Reconstruct Time has expired, and the drive is either repositioning or has stopped.
5 (HSPD)	HIGH SPEED - The transport is in High Speed mode. When reset, indicates that the drive is in Low Speed mode. The drive always reverts to Low Speed after a Rewind.
6 (BOT)	BEGINNING OF TAPE - The drive is at Load Point. It stays set until the BOT marker leaves the photosensor area in the forward direction.
7 (EOT)	END OF TAPE - The EOT marker is sensed in forward direction and becomes latched. It stays set until the EOT marker leaves the photosensor area in reverse direction.

4.10.1.3 ASCII Port Printout of Sense Byte Information - The ASCII port printout (Figures 4-37A, 4-37B, and 4-37C) contains information detailing the activity of the transport during execution of the last command received. The information is transferred to the Host as part of the Error Log Message. Details of information contained in bytes as designated in the ASCII port printout follow Figure 4-37C. ASCII port operation is described in paragraph 5.10.

Figure 4-37A. ASCII Port Printout

7	6	5	4	3	2	1	0	SENSE BYTE	ASCII ADDRESS
COMPARE ERROR	READ PARITY	RAM/FIFO OVERFLOW/ OVERRUN		BUFFER PARITY ERROR	MSCP I/F PARITY ERROR	RAM PARITY ERROR	ROM PARITY ERROR		4257
NON- EXISTENT MEMORY	LES1 I/F PARITY ERROR	HOST I/F PARITY ERROR							4258
COMMAND REJECT	INTER- VENTION REQUIRED		EQUIPMENT CHECK	DATA CHECK		UNIT CHECK	UNIT EXCEPTION	0	4259
ILLEGAL CHANNEL COMMAND	DEVICE COMMAND CHECK		FILE PROTECTED	RESET KEY		DEVICE NOT READY	DEVICE OFF-LINE	1	425A
CHANNEL PARITY ERROR	CHANNEL RESPONSE CHECK	READ HARDWARE CHECK	WRITE HARDWARE CHECK	DEVICE RESPONSE CHECK	DEVICE HARDWARE CHECK	VELOCITY CHECK	DEVICE INTERRUPT CHECK	2	425B
AGC FAULT		READ DATA CHECK	ID FAULT		ERROR RECOVERY CODE UNRECOVER- ABLE BOT TAPE MOVED			3	425C
COMMAND CODE								4	425D
GCR MODE	HIGH SPEED MODE	AUTO SPEED MODE	FILE MARK DETECTED	DIAGNOSTIC MODE	START/ STOP MODE	VARIABLE GAP MODE (LONG)	VARIABLE GAP MOD. (SHORT)	5	425E

7	6	5	4	3	2	1	0	SENSE BYTE	ASCII ADDRESS
DIAGNOSTIC FAULT CODE									425F
DIAGNOSTIC FAULT SUB-CODE									4260
WRITE ERROR SYMPTOM CODE									4261
WRITE TRANSFER CHECK	RESIDUAL BYTE COUNT CHECK	WRITE CRC PARITY ERROR	45 PARITY ERROR		WRITE AUX CRC PARITY ERROR			6	4262
RESIDUAL CHECK	READ CRC CHECK	READ AUX CRC CHECK	RESYNC CHECK	ECC3 CHECK	UNCORRECT- ABLE DATA	NO TRACK	EXCESSIVE POINTERS	7	4263
NOISE CHECK	POSTAMBLE ERROR	SKEW ERROR	READ TIME-OUT	WRITE TAPE MARK CHECK	ID CHECK	ARA BURST CHECK	ARA ID CHECK	8	4264
EC HARDWARE CHECK	READ BUFF IN PARITY ERROR	READ TRANSFER CHECK	READ DATA PARITY ERROR	END MARK CHECK	DUAL TRACK CORRECTION	SINGLE TRACK CORRECTION	TIE (4)	9	4265
TIE 7	TIE 6	TIE 5	TIE 3	TIE 9	TIE 1	TIE 8	TIE 2	10	4266
READ ERROR SYMPTOM CODE									4267

Figure 4-37B. ASCII Port Printout

7	6	5	4	3	2	1	0	SENSE BYTE	ASCII ADDRESS
READY	ONLINE	REWIND	FILE PROTECTED	GAP CONTROL	HIGH SPEED	BOT	EOT	11	4268
REVERSE	WRITE	DSE	GCR	LONG GAP	START/STOP MODE			12	4269
REMOTE DIAG. INHIBIT	REMOTE DIAG.	LWR I/F	LWR PE	LWR GCR		LOCAL DENSITY SELECT	GCR DEFAULT DENSITY		426A
COMMAND REJECT	INTER- VENTION REQUIRED	DIAG. REQUEST	DENSITY CHANGE	AGC CHECK	RESET KEY	REVERSE IN BOT	AIRFLOW/ TEMPERATURE CHECK	13	426B
COMMAND CODE								14	426C
MARGINAL CONDITION CODE								15	426D
FAULT/TEST COMPLETION CODE									426E
SUB-FAULT/SUB-TEST COMPLETION CODE									426F
UNIT NUMBER									4270
MICROCODE REVISION LEVEL									4271

Figure 4-37C. ASCII Port Printout

ASCII Address 4257

The information in this byte reflects TMSCP operation.

Bit 7 - COMPARE ERROR. An error was detected from the comparison of data read to/from tape and from/to the Host.

- Bit 6 - READ PARITY ERROR
- Bit 5 - RAM/FIFO OVERFLOW/OVERRUN
- Bit 4 - Not Used
- Bit 3 - BUFFER PARITY ERROR
- Bit 2 - MSCP INTERFACE ERROR
- Bit 1 - RAM PARITY ERROR
- Bit 0 - ROM PARITY ERROR

ASCII Address 4258

This byte reflects operation of the LESI module.

- Bit 7 - NON-EXISTENT MEMORY
- Bit 6 - LESI INTERFACE PARITY ERROR
- Bit 5 - HOST INTERFACE PARITY ERROR
- Bit 4 thru 0 - Not Used

ASCII Address 4259

Sense Byte 0

- Bit 7 - COMMAND REJECT. An invalid command was received from Host Adaptor. Detailed information is available from bits 7 through 4 of sense byte 1.
- Bit 6 - INTERVENTION REQUIRED. A condition exists that must be corrected by the Operator or Host system before normal operations can be resumed. Detailed information is available from bits 3 through 0 of sense byte 1.
- Bit 5 - Not Used.
- Bit 4 - EQUIPMENT CHECK. Hardware malfunction in the Formatter or Drive. Detailed information is available from remaining sense bytes.
- Bit 3 - DATA CHECK. Uncorrectable data error. Detailed information is available from remaining sense bytes.
- Bit 2 - Not Used.
- Bit 1 - UNIT CHECK. A hard error condition and indicator that at least one of the following flags is also set:
- o DATA CHECK
 - o EQUIPMENT CHECK
 - o INTERVENTION REQUIRED
 - o COMMAND REJECT
- Bit 0 - UNIT EXCEPTION. Marginal acceleration, or error correction was performed on a read.

ASCII Address 425A

Sense Byte 1

- Bit 7 - ILLEGAL CHANNEL COMMAND. Illegal opcode from host (implies hardware malfunction).
- Bit 6 - DEVICE COMMAND CHECK. A READ REVERSE or BACKSPACE command was issued at BOT or Device rejected a formatter command.
- Bit 5 - Not Used.
- Bit 4 - FILE PROTECTED. A WRITE command was issued to a device with no write ring.
- Bit 3 - RESET KEY. The RESET switch on the front panel has been activated.
- Bit 2 - Not Used.
- Bit 1 - DEVICE NOT READY. A device command was received and drive was not ready.
- Bit 0 - DEVICE OFFLINE. A device command was received and the drive was off-line.

ASCII Address 425B

Sense Byte 2

- Bit 7 - CHANNEL PARITY ERROR. Formatter detects either a command or data parity error from the adapter.
- Bit 6 - CHANNEL RESPONSE CHECK. Adapter does not respond to Formatter during diagnostic protocol.
- Bit 5 - READ HARDWARE CHECK. A hardware malfunction occurred in the Formatter Read circuitry. Detailed information is available from sense byte 12.
- Bit 4 - WRITE HARDWARE CHECK. A hardware malfunction occurred in the Formatter Write circuitry. Detailed information is available from sense byte 6.
- Bit 3 - DEVICE RESPONSE CHECK. The device presented incorrect status to the Formatter.
- Bit 2 - DEVICE HARDWARE CHECK. A hardware malfunction occurred in the drive. Detailed information is available from drive sense bytes.
- Bit 1 - VELOCITY CHECK. The drive did not come up to speed in the required time.
- Bit 0 - DEVICE INTERRUPT. A DEVICE INTERRUPT occurred during the operation.

ASCII Address 425C

Sense Byte 3

Bit 7 - AGC FAULT. Gain could not be set properly in GCR during ARA burst.

Bit 6 - PE CRC CHECK.

Bit 5 - READ DATA CHECK. The Formatter read logic detected an error.

Bit 4 - ID FAULT. The Formatter detected a bad ID field on the tape.

Bit 3 - Not Used.

Bits 2 thru 0 - ERROR RECOVERY CODE.

- o Bit 2 - UNRECOVERABLE ERROR
- o Bit 1 - ERROR OCCURRED AT BOT; REWIND is required
- o Bit 0 - TAPE MOVED

ASCII Address 425D

Sense Byte 4 - Sense byte 4 is the code in binary of the Formatter command that was executed.

BIT 7 BIT 6 BIT 5 BIT 4 BIT 3 BIT 2 BIT 1 BIT 0

FORMATTER COMMAND CODE

ASCII Address 425E

Sense Byte 5 - Sense byte 5 is the Formatter status byte (paragraph 4.9.2.2).

Bit 7 - GCR MODE. The Formatter was in GCR mode during the last operation.

Bit 6 - HIGH SPEED MODE. The Formatter was in high speed mode during the last operation.

Bit 5 - AUTO SPEED MODE. The speed is automatically selected by the Formatter to provide optimum throughput.

Bit 4 - FILE MARK DETECTED. A file mark was detected during the last operation.

Bit 3 - DIAGNOSTIC MODE. Only set while executing a diagnostic test.

Bit 2 - START/STOP MODE. The Formatter was in Start/Stop mode during the last operation.

Bit 1 - VARIABLE LONG GAP MODE. The Formatter was in the Variable Long Gap Mode during the last operation.

Bit 0 - VARIABLE SHORT GAP MODE. The Formatter was in the Variable Short Gap Mode during the last operation.

ASCII Address 425F

BIT 7 BIT 6 BIT 5 BIT 4 BIT 3 BIT 2 BIT 1 BIT 0

DIAGNOSTIC FAULT CODE

ASCII Address 4260

BIT 7 BIT 6 BIT 5 BIT 4 BIT 3 BIT 2 BIT 1 BIT 0

DIAGNOSTIC FAULT SUB-CODE

Bytes 6 and 7 represent the Formatter Completion Code and Sub-Code when executing a diagnostic.

ASCII Address 4261

This byte is a Write Error Symptom Code that designates a Formatter microprogrammed routine which was in the process of executing when an error was detected. This is used for diagnosing errors.

BIT 7 BIT 6 BIT 5 BIT 4 BIT 3 BIT 2 BIT 1 BIT 0

WRITE ERROR SYMPTOM CODE

ASCII Address 4262

Sense Byte 6 - Sense byte 6 is a further breakdown of the Write Hardware Check bit in sense byte 2.

Bit 7 - WRITE TRANSFER CHECK. Indicates a malfunction in the write strobe generator.

Bit 6 - RESIDUAL BYTE COUNT CHECK. Indicates a malfunction in the formatter latency buffer, resulting in the wrong number of residual bytes at the end of an operation.

Bit 5 - WRITE CRC PARITY ERROR. Indicates a malfunction in the write CRC generator.

Bit 4 - 45 PARITY ERROR. Indicates a malfunction in the GCR write 4-to-5 conversion logic.

Bit 3 - Not Used.

Bit 2 - WRITE AUX CRC PARITY ERROR. Indicates a malfunction in the write AUX CRC generator.

Bit 1 - Not Used.

Bit 0 - Not Used.

ASCII Address 4263

Sense Byte 7 - Sense byte 7 is a further breakdown of data check in sense byte 0.

Bit 7 - RESIDUAL CHARACTER CHECK. The GCR residual character is in error.

Bit 6 - READ CRC CHECK. The GCR CRC character is in error.

Bit 5 - READ AUX CRC CHECK. The GCR auxiliary character is in error.

Bit 4 - RESYNC ERROR. An error was detected in the GCR resync group.

Bit 3 - ECC3 CHECK. An error was detected on the corrected data. This bit sets the UNCORRECTABLE DATA error bit.

Bit 2 - UNCORRECTABLE DATA. An uncorrectable error was encountered in the data.

Bit 1 - NO TRACK POINTER. An error was detected in PE mode and no track pointer was specified. This bit sets the UNCORRECTABLE DATA error bit.

Bit 0 - EXCESSIVE POINTERS. An error was detected in GCR mode and more than 2 pointers were specified. This bit sets the UNCORRECTABLE DATA error bit.

ASCII Address 4264

Sense Byte 8 - Sense byte 8 is further breakdown of data check in sense byte 0.

Bit 7 - NOISE CHECK. Indicates an incomplete or marginal erase operation.

Bit 6 - POSTAMBLE ERROR. An error was detected in the postamble.

Bit 5 - SKEW ERROR. Excessive skew was detected.

Bit 4 - READ TIMEOUT. A long gap was detected during a read operation or the read-after-write data was not detected within a predetermined window.

Bit 3 - WRITE TAPE MARK CHECK. A read-after-write error was detected while writing a tape mark.

Bit 2 - ID CHECK. An error was detected in the ID burst in PE or GCR mode.

Bit 1 - ARA BURST CHECK. An error was detected during the ARA burst in GCR mode.

Bit 0 - ARA ID CHECK. An error was detected in the ARA ID in GCR mode.

ASCII Address 4265

Sense Byte 9 - Sense byte 9, bits 0 thru 2, is a further breakdown of the Read Hardware Check in sense byte 2.

Bit 7 - EC HARDWARE CHECK. A malfunction occurred in error correction hardware.

Bit 6 - READ BUFFER IN PARITY ERROR. A parity error occurred on read data into the latency buffer.

Bit 5 - READ TRANSFER CHECK. A malfunction occurred in the read strobe generator.

Bit 4 - READ DATA PARITY ERROR. A parity error was detected by the read circuitry while passing data to the read output buffer during diagnostics.

Bit 3 - END MARK CHECK. Missing end mark in GCR mode.

Bit 2 - DUAL TRACK CORRECTION. Dual track correction occurred in GCR mode.

Bit 1 - SINGLE TRACK CORRECTION. Single track correction occurred in PE or GCR mode.

Bit 0 - TIE 4 (P). The parity track was in error.

ASCII Address 4266

Sense Byte 10 - Sense byte 10 is a further breakdown of the Data Check in sense byte 0. Sense byte 10 designates the track in error (TIE), excluding the parity track, which is in sense byte 9.

BIT 7	BIT 6	BIT 5	BIT 4	BIT 3	BIT 2	BIT 1	BIT 0
TIE 7	TIE 6	TIE 5	TIE 3	TIE 9	TIE 1	TIE 8	TIE 2

ASCII Address 4267

BIT 0 BIT 1 BIT 2 BIT 3 BIT 4 BIT 5 BIT 6 BIT 7

READ ERROR SYMPTOM CODE (RESC)

This byte contains the error symptom code for read errors. The upper 4 bits are the routine and the lower 4 are the error symptom code.

ASCII Address 4268

Sense Byte 11 - Sense byte 11 is the Device Status byte (paragraph 4.9.2.2).

BIT 7 BIT 6 BIT 5 BIT 4 BIT 3

READY ONLINE REWIND FILE PROTECTED GAP CONTROL

BIT 2 BIT 1 BIT 0

HIGH SPEED BOT EOT

ASCII Address 4269

Sense Byte 12 - Sense byte 12 represents drive status for the last command issued.

Bit 7 - REVERSE. When set, indicates Reverse tape motion; when reset, indicates Forward tape motion.

Bit 6 - WRITE. When set, indicates a Write operation; when reset, indicates a Read operation.

Bit 5 - DATA SECURITY ERASE (DSE). When set, indicates a Data Security Erase.

Bit 4 - GCR. When set, indicates GCR mode; when reset, indicates PE mode.

Bit 3 - VARIABLE LONG GAP. When set, indicates Variable Long Gap; when reset, indicates Normal Gap.

Bit 2 - START/STOP MODE. When set, indicates Start/Stop mode; when reset, indicates Streaming mode.

Bit 1 - Not Used.

Bit 0 - Not Used.

ASCII Address 426A

This byte represents diagnostic status from the drive.

Bit 7 - REMOTE DIAGNOSTIC INHIBIT.

Bit 6 - REMOTE DIAGNOSTIC. A diagnostic test was being executed from the host.

Bit 5 - LWR I/F. A Loop Write-to-Read diagnostic test was being executed on the Drive/Formatter interface.

Bit 4 - LWR PE. A Loop Write-to-Read diagnostic test was being executed in PE mode through the drive's read/write hardware.

Bit 3 - LWR GCR. A Loop Write-to-Read diagnostic test was being executed in GCR mode through the drive's read/write hardware.

Bit 2 - Not Used.

Bit 1 - LOCAL DENSITY SELECT.

Bit 0 - GCR DEFAULT DENSITY.

ASCII Address 426B

Sense Byte 13 -Sense byte 13 represents drive status associated with a device interrupt.

Bit 7 - COMMAND REJECT. An invalid command was received from the STU adapter. Rejected command is available at ASCII Address 426C.

Bit 6 - INTERVENTION REQUIRED. A condition must be corrected by the operator or host system before normal operation can be resumed.

Bit 5 - DIAGNOSTIC REQUEST. The drive notified the Formatter that a local diagnostic is to be executed.

Bit 4 - DENSITY CHANGE.

Bit 3 - AGC CHECK. The drive could not set up AGC correctly in GCR mode.

Bit 2 - RESET KEY. The RESET switch on the drive panel was activated.

Bit 1 - REVERSE IN BOT. BOT was encountered while the drive was going in Reverse.

Bit 0 - AIRFLOW/TEMPERATURE CHECK.

ASCII Address 426C

COMMAND CODE. This contains a representation of the drive's last rejected command code.

ASCII Address 426D

MARGINAL CONDITION CODE.

Bit 7 - HSPD Up Ramp Time-out of marginal limits

Bit 6 - LSPD Up Ramp Time-out of marginal limits

Bit 5 - HSPD Down Ramp Time-out of marginal limits

Bit 4 - LSPD Down Ramp Time-out of marginal limits

Bit 3 - HSPD Speed

Bit 2 - LSPD Speed

Bit 1 - LSPD AGC

Bit 0 - HSPD AGC

ASCII Address 426E

FAULT/TEST COMPLETION CODE. This byte contains a representation of the internally detected failure mode when a hard error occurs. This is the code displayed on the operator control panel. In remote diagnostics, this byte contains the test completion code.

ASCII Address 426F

SUB-FAULT/SUB-TEST COMPLETION CODE. This byte contains a representation of the internally detected sub-fault code when a hard error is detected. In remote diagnostics, the byte contains the test subcompletion code.

ASCII Address 4270

UNIT NUMBER. This byte contains a representation of the unit identification number.

ASCII Address 4271

MICROCODE REVISION LEVEL. This byte contains a representation of the microcode revision level.

4.10.2 STI Interface Controller Module

The commands from a host are transferred from the host to the STI module through the L0108-YB Tape Data Channel (TDC) module mounted in an HSC. Appendix D contains a functional description of the STI module and information about STI protocol.

Since the STI module (in the TA81) communicates with the same Formatter modules as the TMSCP module (in the TU81), the descriptions of the interface lines, commands, status information, and ASCII port printout provided in the previous paragraphs also apply to the STI Interface module.

4.11 INTERFACE AND TIMING CONSIDERATIONS

4.11.1 Motion Characteristics

The transport has two operational speeds: 25 ips and 75 ips. Selection of either speed is made at the interface, with 25 ips being the default mode. Also, following a rewind operation, the transport automatically reverts to 25 ips.

In the ensuing discussions, read operations represent all read-type operations such as READ, SPACE and SEARCH. Similarly, write operations represent all write-type operations such as WRITE DATA, ERASE and WRITE FILE MARK.

4.11.2 Start/Stop Mode

In the start/stop mode, the transport operates similar to a conventional 1/2 inch tape unit. It accelerates the tape when a command is received and stops the tape within the IBG. A long IBG of 1.2 inch nominal in PE or 0.6 inch in GCR may be commanded as well as the normal or 0.7 inch nominal IBG in PE or 0.4 inch in GCR.

4.11.2.1 Read Operations - After a block has been successfully traversed, the tape is brought to a complete stop to await the next command. The microprocessor delays the subsequent start if the time since the last start is less than 80 ms.

NOTE

In start/stop mode, the tape is stopped between records regardless of reinstruct timing.

4.11.2.2 Write Operations - Tape control is the same as in the Read case; the 80 ms restriction also applies. Note that the nominal IBG written in this mode is 0.7 inch in PE and 0.4 inch in GCR.

4.11.2.3 Other Start/Stop Motion Characteristics - Whenever a change from read to write mode is experienced (forward direction), a "jog" operation is performed in order to position the erase within the IBG. The time to execute the jog operation is nominally 191 milliseconds in PE and (TBD) in GCR. When changing from Write to Read Reverse or Rewind, a Forward Jog to erase a full gap is inserted by the transport. This insures that there will be no glitch in the initial gap when the write head is turned off. Time to execute the Forward Jog is 120 milliseconds in PE and (TBD) in GCR.

4.11.3 Streaming Modes (25 ips and 75 ips)

The streaming modes are high performance operating modes designed to accommodate contiguous transfers of many data blocks to or from tape. Unlike the start/stop mode, tape acceleration and deceleration cannot be accomplished within the Interblock Gap (IBG). In order to efficiently utilize the streaming mode, tape motion must be sustained by commanding successive data operations. This is accomplished by issuing subsequent commands to the transport during the time the transport is traversing the IBG. (This command window is referred to as the command reinstruction time.) Should a follow-up command not be received during the reinstruction interval, a repositioning cycle is required. (A Reverse command can be received during the initial down ramp and reverse ramp up, and will be executed without going through the complete repositioning cycle.) By way of illustration, consider this 75 ips case. Assume that the transport is in PE mode and has just completed a write data operation; if the normal IBG length of 0.6 inch is commanded by the system, then the system has 6.0 ms to respond with a subsequent Write command in order for streaming mode to be sustained. If the subsequent WRITE command is not received by the end of the reinstruction interval, the transport repositions itself in anticipation of the next streaming mode command.

There are three sequences of events which generally describe the motion characteristics of the transport in the streaming mode. These sequences are:

- o Case 1 - Command Received During Reinstruction Interval
- o Case 2 - Command Received During Repositioning Cycle
- o Case 3 - Command Received Following Repositioning Cycle

These three sequences are applicable to both forward and reverse operations and are described individually on the following pages. First, a more general discussion of streaming mode motion characteristics is presented.

(See Figure 4-38) In order for the transport to perform a data operation on Block N + 1 from a stopped position (point E), it must first accelerate and be up to speed at point F as referenced to the read head in the case of a read-type operation, or erase head in the case of a write-type operation. For the case where the transport has just completed a data operation on Block N and a repositioning cycle is required, the transport begins the repositioning cycle at point B and traverses path BCDE. The transport then positions itself at point E in anticipation of the next operation. The transport presumes the next operation to be a streaming mode operation on Block N + 1. A sequence chart is presented in Table 4-1 which identifies transport streaming mode motion sequences for combinations of previous and present command issuances.

In all cases, the next command is received during the reinstruct time. This chart refers to the diagram of Figure 4-38.

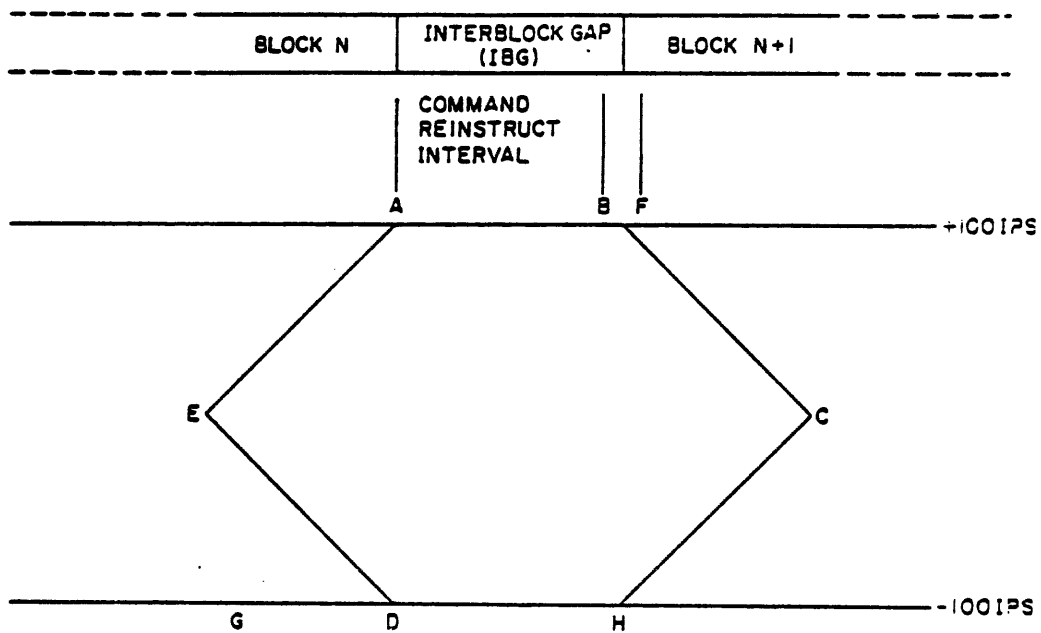

Figure 4-38. STREAMING MODE VELOCITY DIAGRAM

Table 4-1. STREAMING MODE MOTION SEQUENCE CHART

PREVIOUS COMMAND	NEXT COMMAND		
	FORWARD READ-TYPE	REVERSE READ-TYPE	WRITE-TYPE
Forward Read-Type	Path ABF	Paths ABC, CHDG	Path ABCDEF
Reverse Read-Type	Paths HDE, EABF	Path HDG	Paths HDE, EABF
Write-Type	Not Recommended	Paths ABC, CHDG	Path ABF

4.11.3.1 Case 1 (Non-Stop) - Command Received During Reinstruction Interval. A command is received sometime during the command restruct period following the data operation on Block N. Note that the velocity profile at the bottom of the figure indicates that full velocity is maintained without interruption through the processing of Block N and N + 1 (see Figure 4-39).

4.11.3.2 Case 2 (Momentary Stop) - Command Received During Repositioning Cycle. A command is not received during the Command Restruct period, but rather is received during the Repositioning Cycle. The diagram illustrates, in the distance domain, the sequence of events with respect to the transport motion and the command transfer (see Figure 4-40).

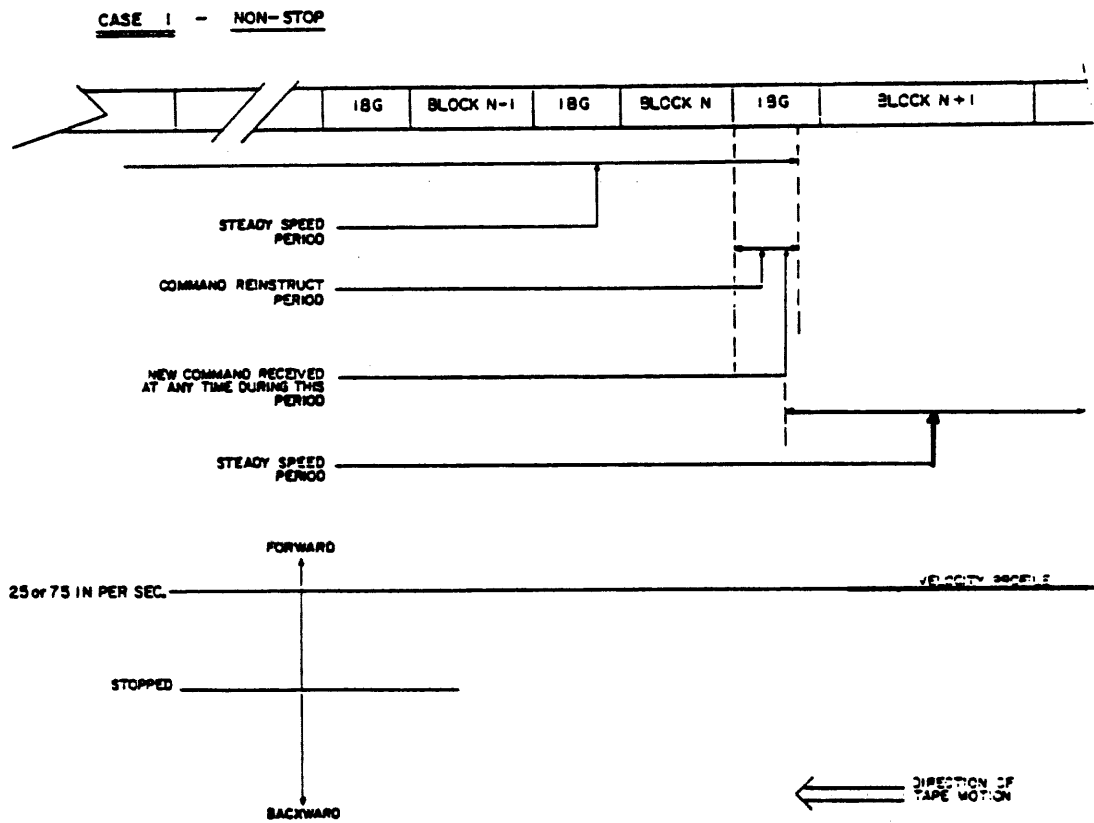

Figure 4-39. TAPE MOTION CONTROL - Case 1

The velocity profile (Figure 4-40) illustrates, in the time domain, tape velocity characteristics. Looking at the diagram of Figure 4-41, it can be seen that the tape stops only momentarily to change direction. The velocity profile identifies the time sequence of events. The correspondence between the time and distance portrayals in sequence is as follows:

<u>EVENT</u>	<u>Velocity Profile Position</u>
Steady Speed Period	Up to Point A
Forward Motion Deceleration	A-B
Tape Motion Stopped Momentarily	B
Reverse Motion Acceleration	B-C
Full Speed Reverse Motion	C-D
Reverse Motion Deceleration	D-E
Tape Motion Stopped Momentarily	E
Forward Motion Acceleration	E-F
Steady Speed Forward Through Data Block N + 1	Point F and On

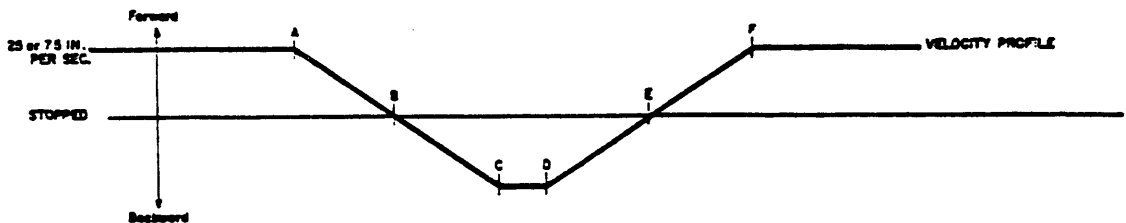

Figure 4-40. VELOCITY PROFILE - Case 2

TAPE MOTION CONTROL
STREAMING MODE - 75 INCHES/SEC. & 25 INCHES /SEC.

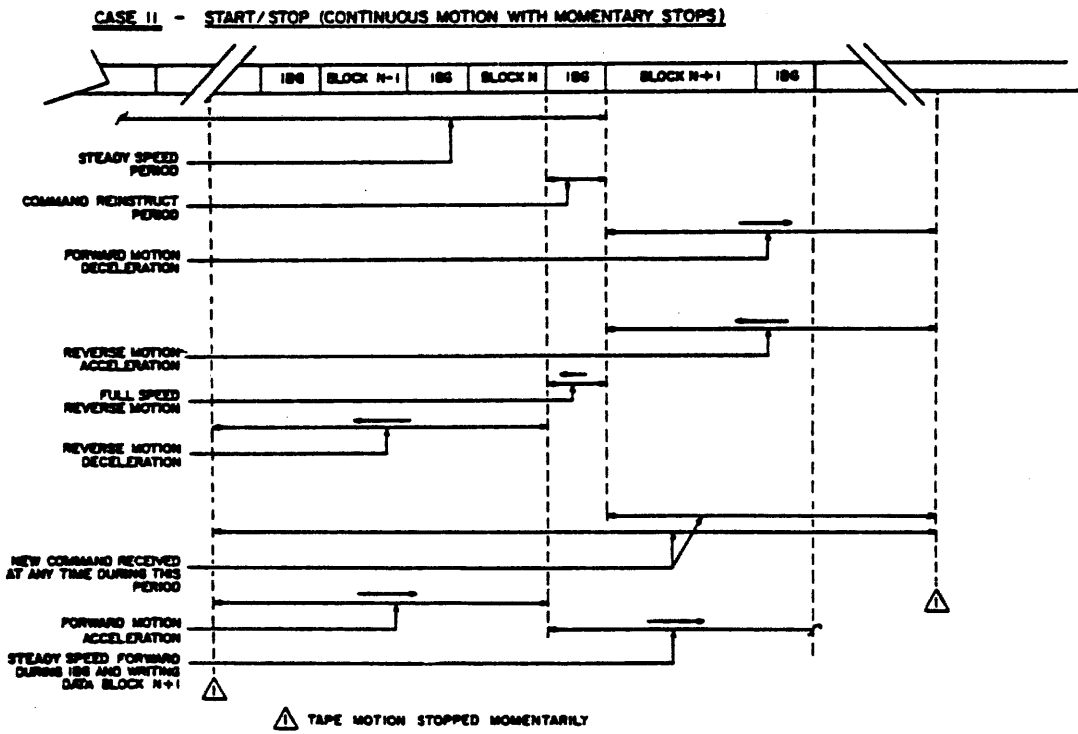

Figure 4-41. TAPE MOTION CONTROL - Case 2

4.11.3.3 Case 3 (Wait For Command) - Command Received Following Repositioning Cycle (Figure 4-42). Very similar to Case 2 except that the subsequent command is not received until the tape has come to rest at point E1. The tape is then not accelerated until time E2 when the new command is received. Other than for this delay in receiving the next command, the correspondence between the time and distance domain portrayals is the same for Cases 2 and 3 (refer to Figure 4-43).

<u>EVENT</u>	<u>Velocity Profile Position</u>
Steady Speed Period	Up to Point A
Forward Motion Deceleration	A-B
Tape Motion Stopped Momentarily	B
Reverse Motion Acceleration	B-C
Full Speed Reverse Motion	C-D
Reverse Motion Deceleration	D-E1
Tape Motion Stopped While Awaiting New Command	E1-E2
Forward Motion Acceleration	E2-F
Steady Speed Forward Through Data Block N + 1	Point F and On

Important to note is that the transport performs all repositioning without system or controller intervention.

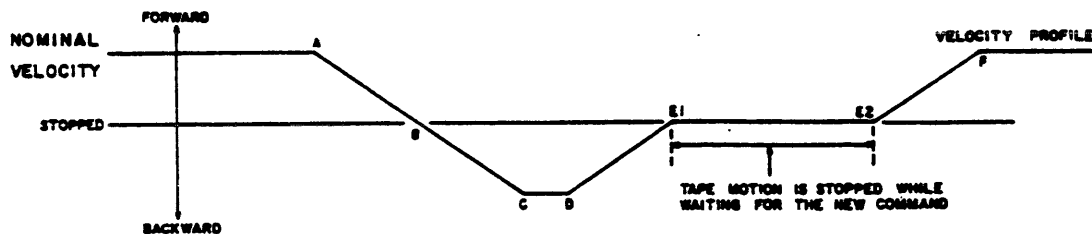

Figure 4-42. VELOCITY PROFILE - Case 3

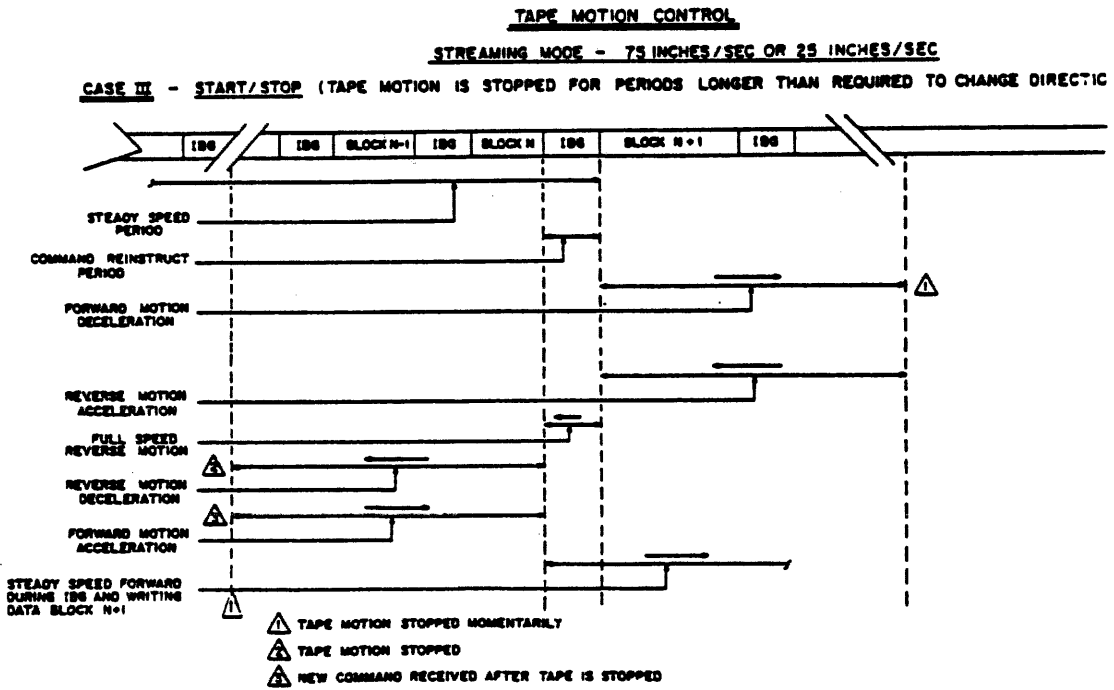

Figure 4-43. TAPE MOTION CONTROL - Case 3

4.11.4 25 ips Mode Control

The transport automatically switches between 25 ips streaming mode and 25 ips start/stop mode in response to system usage. Essentially, when repositioning becomes excessive in streaming mode, rather than continue to 'thrash', the STU will switch to start/stop mode.

The transport switches back to streaming mode when the command Reconstruct Time consistently reduces to a value that would allow streaming.

NOTE

To avoid 'jog' delays, mode switching is done at 25 ips rather than when stationary. In essence, a mode switch takes effect at the end of the block in process.

Section 5 - MAINTENANCE

5.1 GENERAL

The first portion (paragraphs 5.2 and 5.3) of the maintenance section contains instructions on how to remove and replace all field replaceable parts or assemblies. Location and identification of assemblies can be referenced to the TU81/TA81 Illustrated Parts Breakdown (EK-TUA81-IP).

Reference into the removal/replacement procedures is primarily via the diagnostic test documentation and fault code interpretation found in the TU81/TA81 Pathfinder (EK-TUA81-SV). Verification tests follow each of the replacement procedures so that the integrity of the replaced assembly can be ensured, prior to returning the transport to on-line status.

The removal/replacement procedures follow a concept of modular (assembly) replacement only. Individual circuit troubleshooting or assembly repair are not recommended and are, therefore, not within the scope of this manual.

Unless otherwise specified, in all procedures it is assumed that the tape has been unloaded, the transport is powered down, and the input power cord is disconnected.

The second portion (paragraph 5.4) of this section describes the TU81/TA81 diagnostic test procedures and the resident tests used for both troubleshooting and operational verification of the TU81/TA81 subsystem. Corrective action in the diagnostic section is of a general nature and should not be used exclusively for transport troubleshooting. Refer to the TU81/TA81 Pathfinder (EK-TUA81-SV) for more detailed test descriptions and fault isolation procedures. Also described are the ASCII port diagnostics.

5.2 ACCESS TO COMPONENTS

Components located on the underside of the tape deck can be accessed for maintenance purposes by placing the tape deck in the maintenance position. Using Figure 5-1 for reference, proceed as follows:

o Maintenance Position

1. Place the top cover in the fully opened position.
2. Using a 5/32 inch Allen wrench, open the front door.

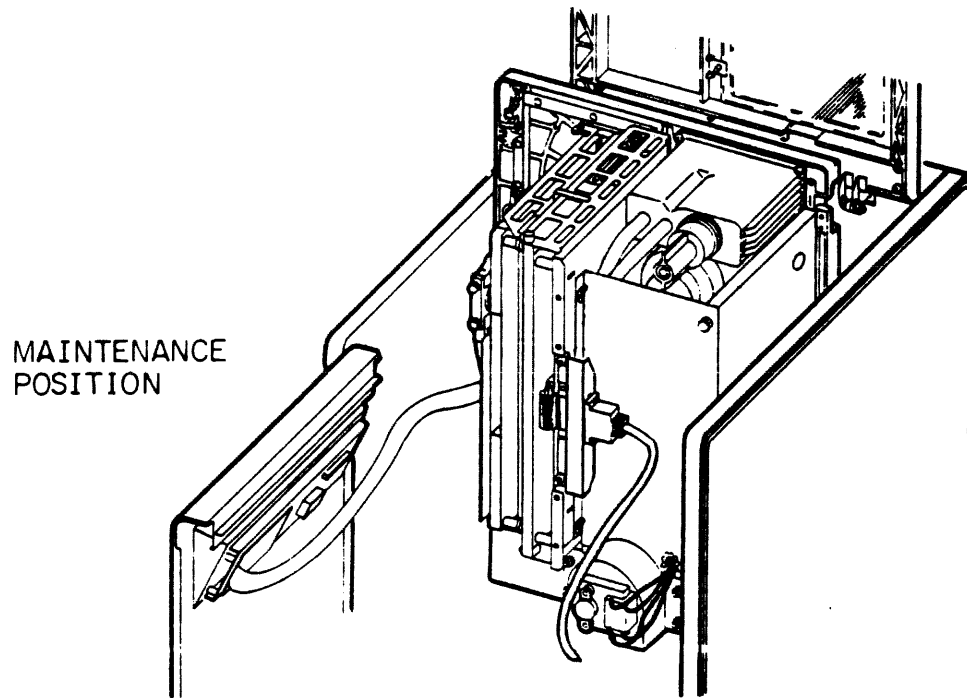
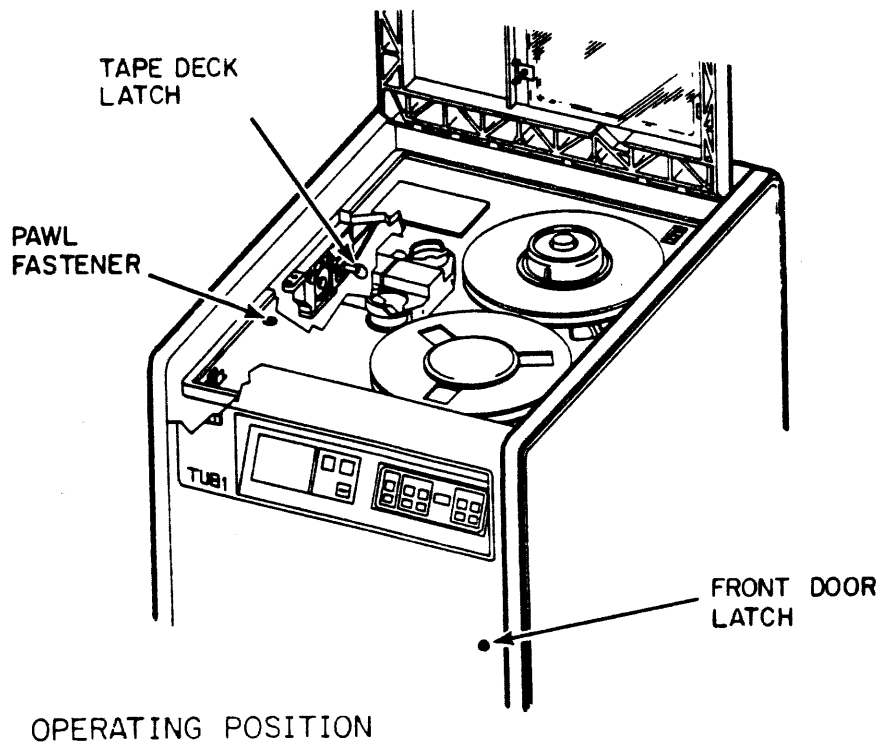

Figure 5-1. TU81/TA81 MAINTENANCE ACCESS

3. Using a straight slot screwdriver, rotate the pawl fastener on the front left corner of the tape deck one-quarter turn counterclockwise to release the deck. Rotate the fastener six more turns counterclockwise to disengage the pawl fully.
4. While pressing down on the front of the tape deck, pull out on the ring of the spring-loaded tape deck latch. With the latch handle extended, pull the tape deck upward and allow the front of the tape deck to rise.
5. Release the tape deck latch and manually tilt the front of the tape deck up until the latch engages and the tape deck is locked in the vertical position. For easier access to some components, the tape deck can be moved from the vertical position to the tilted position for maintenance. To move the tape deck from the vertical to the tilted position, push the top of the tape deck back slightly to relieve pressure on the latch and pull out the latch. Keep pushing the top of the tape deck back until the latch engages in the tilted position.

CAUTION

Use care not to snag or chafe the control panel cable or any other cables when positioning the tape deck.

o Operation Position

1. To return the tape deck to the operating position, pull the tape deck latch out and manually place the deck in the horizontal position until the latch engages. Secure the tape deck by turning the pawl fastener clockwise.

5.2.1 Top Cover Interlock Switch Defeat

When servicing the transport, the Field Service Engineer may need to operate the unit and run diagnostic tests with the top cover open. To bypass the safety interlock switch, insert the defeat tool (supplied in the CD Kit) into the interlock latch. This keeps the interlock switch pressed down, simulating the "top cover closed" condition. See Figure 5-2.

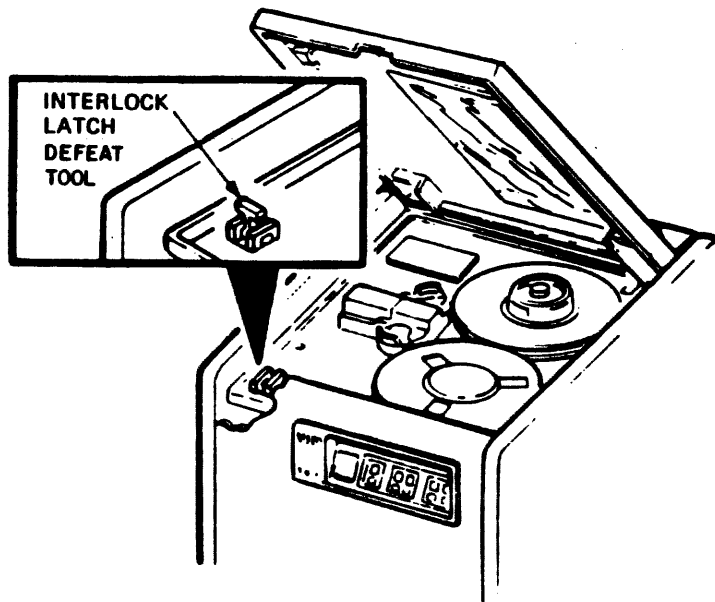

MA-0076-83
02A03-68

Figure 5-2. COVER INTERLOCK DEFEAT TOOL

Figure 5-2A. TU81 CABLE DIAGRAM

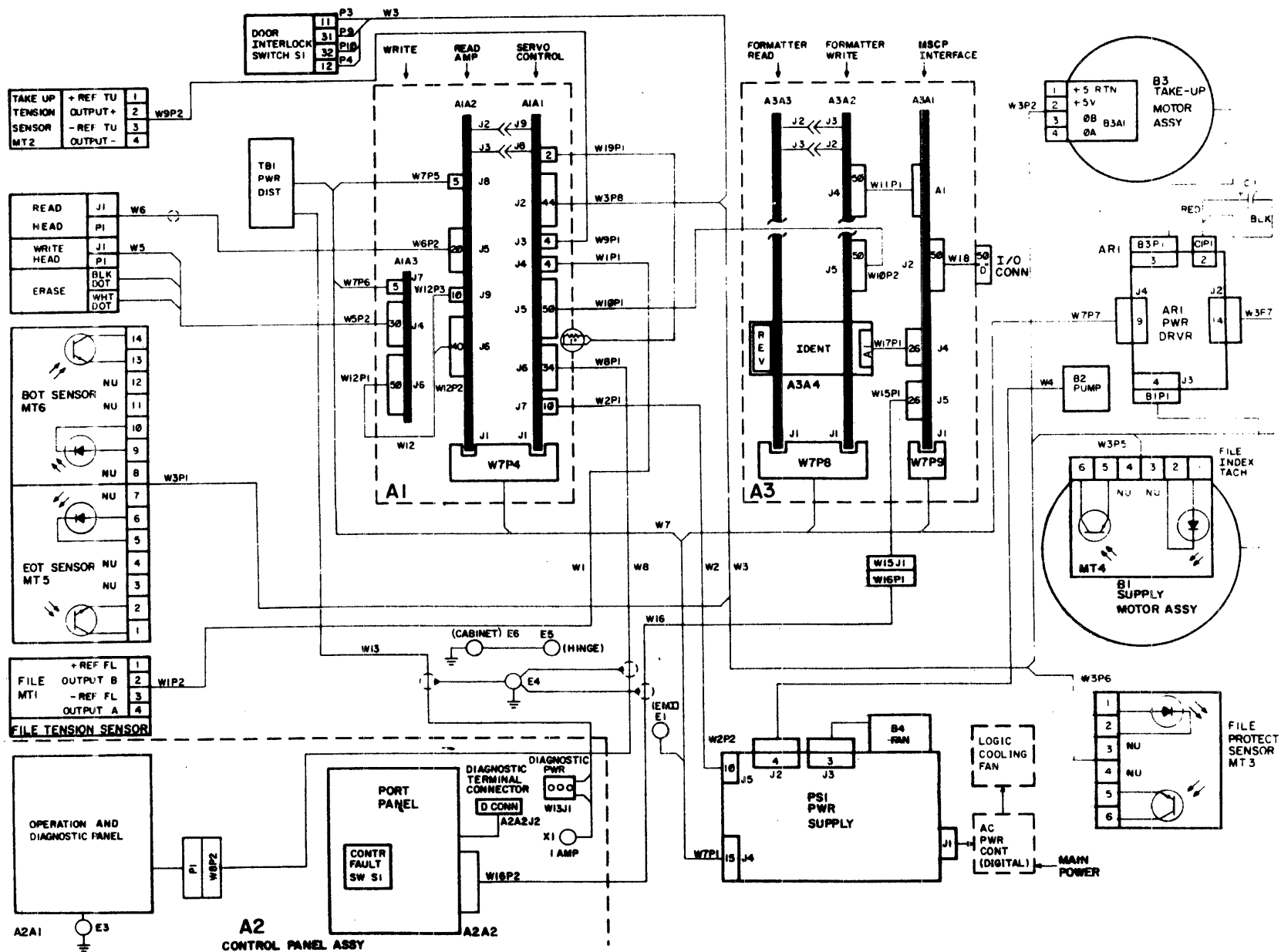
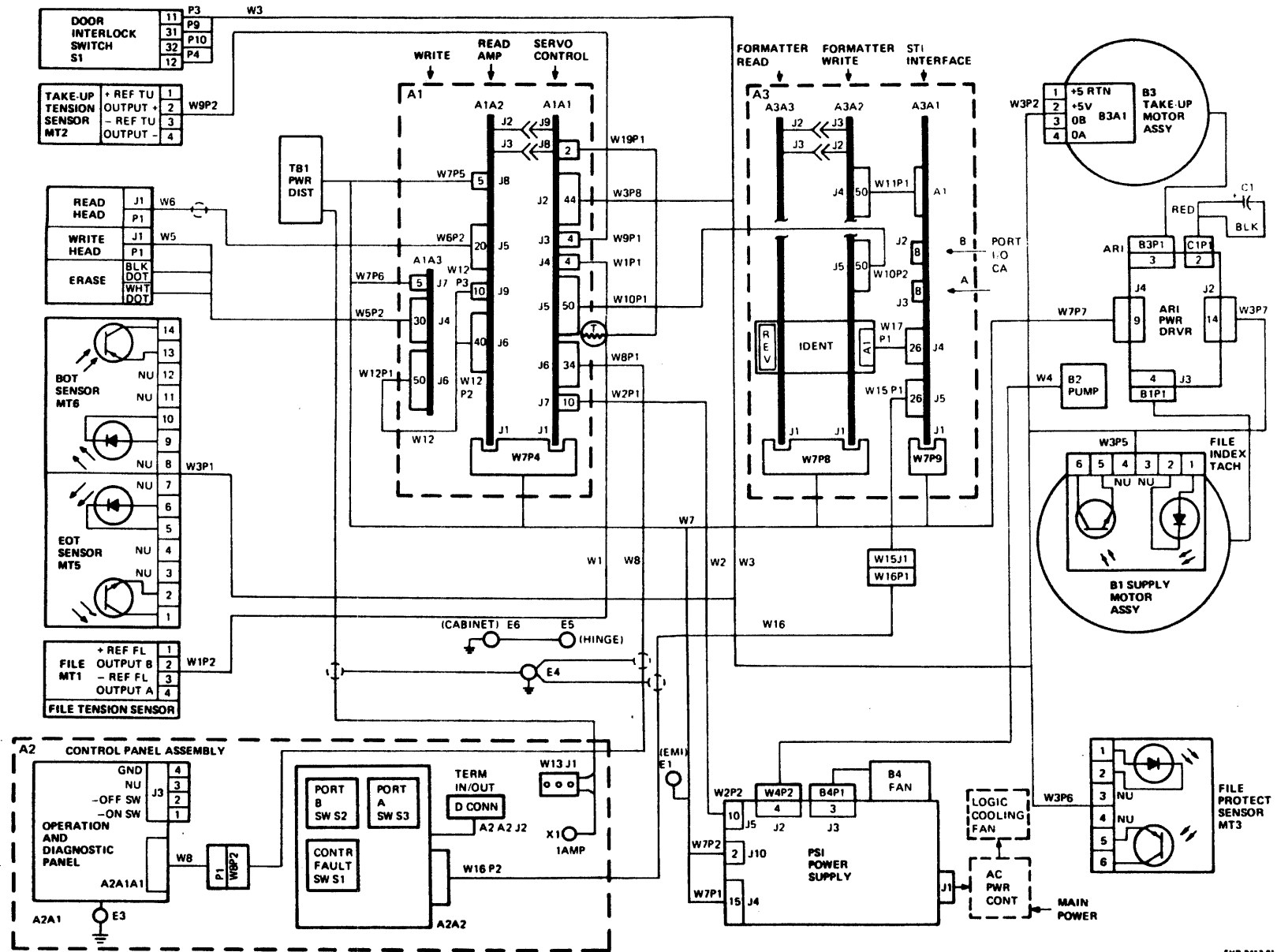

Figure 5-2B. TA81 CABLE DIAGRAM

5-4B



5.3 REMOVAL/REPLACEMENT PROCEDURES

Table 5-1. REMOVAL/REPLACEMENT INDEX

ASSEMBLY	PARA. NO.
Drive Cover Assembly	5.3.1
Tape Cleaner Assembly	5.3.2
Top Cover Interlock Switch	5.3.3
File Protect Sensor	5.3.4
EOT/BOT Sensor Assembly	5.3.5
Take-Up Reel Hub Assembly	5.3.6
Take-Up Reel Motor Assembly	5.3.7
Supply Reel Hub Assembly	5.3.8
Supply Reel Motor Assembly	5.3.9
Supply Motor Tach and Sensor	5.3.10
Air Bearing Sensor	5.3.11
Supply & Take-Up Air Bearing Spring Guide	5.3.12
Pneumatic Pump Assembly	5.3.13
Pressure Regulator & Filter Assembly	5.3.14
Magnetic Head Assembly	5.3.15
Control Panel Assembly	5.3.16
Cooling Fan Assembly	5.3.17
Power Supply	5.3.18
Write Driver/Read Amplifier/Servo Control Modules	5.3.19
Formatter Read Module	5.3.20
Formatter Write Module	5.3.21
Interface Controller Module	5.3.22
Power Amplifier Module	5.3.23
Capacitor	5.3.24

NOTE

The TU81 cable diagram is shown in Figure 5-2A. The TA81 cable diagram is shown in Figure 5-2B.

Appendix B shows the location of electronic modules in the tape transport and their layout.

5.3.1 Drive Cover Assembly

Removal

1. Place the tape deck in the maintenance position (paragraph 5.2).
2. Loosen the nuts and the screws securing the cover and remove the drive cover assembly (Figure 5-3). (The drive cover assembly consists of the drive cover with attached foam strips and grommet.)

Replacement

1. Place the drive cover assembly in position so that the cooling fan wires are placed in the feed-thru hole.
2. Secure the cover with the nuts and the screws.
3. Return the tape deck to the operating position.

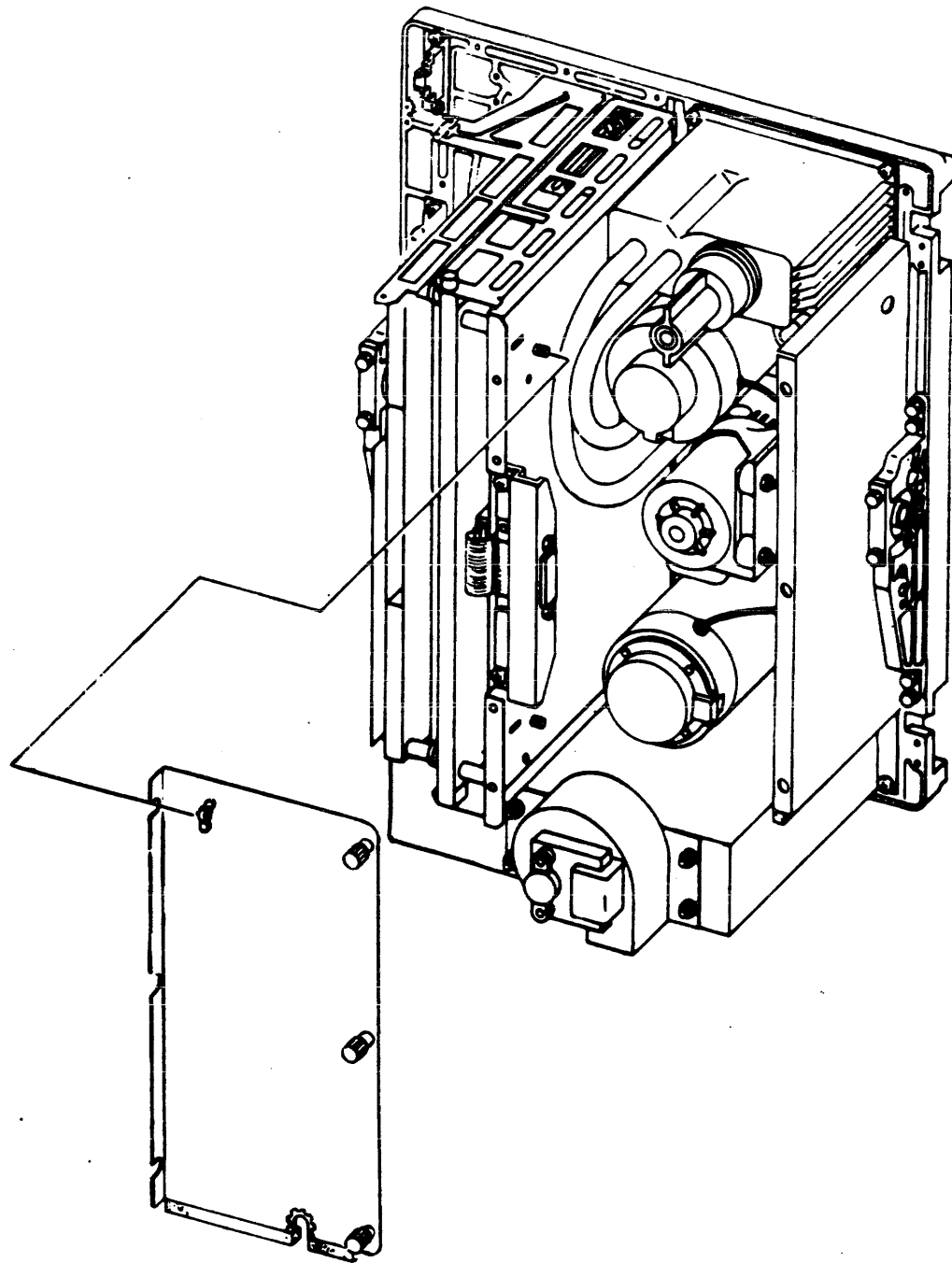

Figure 5-3. DRIVE COVER

5.3.2 Tape Cleaner Assembly

Removal

1. Remove the tape path cover and magnetic head covers from the tape deck.
2. Loosen the two mounting screws and remove the cleaner assembly from the tape deck. See Figure 5-4.
3. Remove screws, lockwashers and cover plate from the blade housing.
4. Slide the platform out from the tape cleaner assembly.

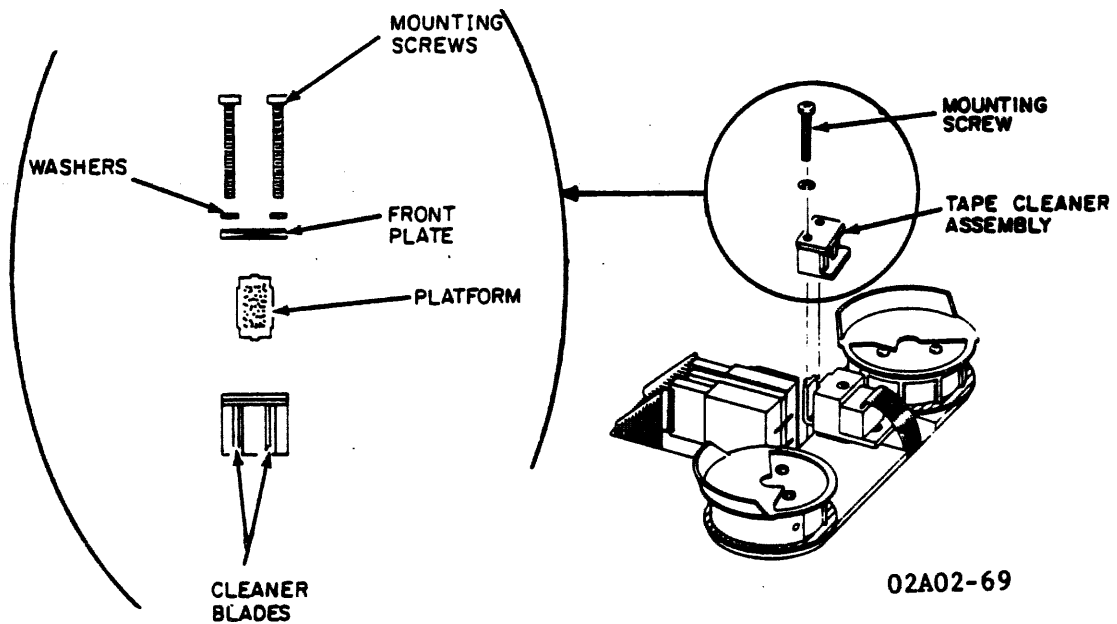

Figure 5-4. TAPE CLEANER

CAUTION

Handle the assembly with care. The cleaner blades are both brittle and sharp.

NOTE

The defective tape cleaner must be replaced as a complete assembly.

5.3.2 Tape Cleaner Assembly (Cont'd)

Replacement

1. Inspect the cleaner blades for damage. If the blades are chipped or damaged, replace the entire assembly.
2. If the blades are not damaged, clean the platform and reinstall. When installing the platform, make sure that the flanges are positioned so that the platform fits firmly inside the cleaner assembly.
3. Install the cover plate, two washers and mounting screws.
4. Position the assembly onto the guide pins on the tape deck and tighten the screws.
5. Reinstall the tape path and magnetic head covers.

Verification Check

1. No functional checks are necessary.

5.3.3 Top Cover Interlock Switch

Removal

1. Place the tape deck in the maintenance position. Remove the four labeled slip-on connectors from the interlock switch connectors. (If any wires are not labeled, identify and mark each wire for reassembly.) See Figure 5-5.
2. Remove the two mounting screws securing the switch plate to the tape deck. Remove the switch and the switch plate.
3. Press the top and the bottom release tabs on the switch to separate the switch from the switch plate.

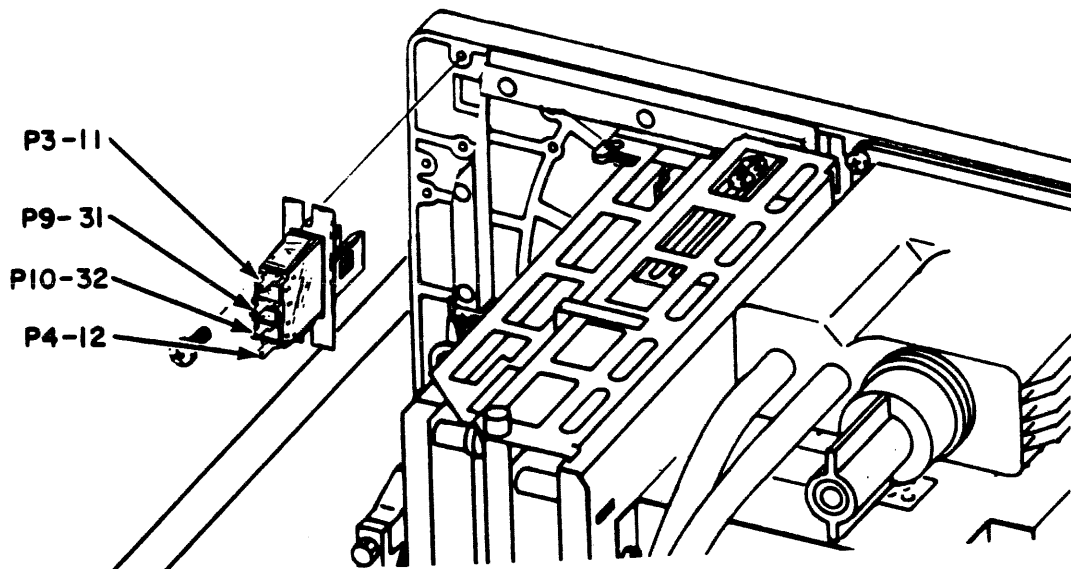

Figure 5-5. TOP COVER INTERLOCK SWITCH (MAINTENANCE VIEW)

5.3.3 Top Cover Interlock Switch (Cont'd)

Replacement

1. Assemble the switch to the switch plate.
2. Position the switch assembly on the rear of the tape deck so that the connector numbers on the switch correspond to the numbers stencilled on the tape deck.
3. Insert the two hex mounting screws. Position the top cover door so that the interlock switch can be aligned with the actuating stud on the door. Tighten the switch mounting screws when the center of the switch front is aligned with the actuating stud.
4. Attach the slip-on connectors to the appropriate studs of the interlock switch. Refer to Figure 5-5 for wire and connector positions. Return the tape deck to the operating position.

Verification Check

1. Thread tape. Do not load. Execute Operator Diagnostic Test #01.

5.3.4 File Protect Sensor

Removal

1. Remove the tape reel from the supply hub.
2. Remove the four mounting screws and the file protect sensor cover plate from the tape deck. See Figure 5-6.
3. Remove the mounting screw and washer securing the file protect sensor to the tape deck.
4. Detach connector W3P6 from the sensor and discard the sensor.

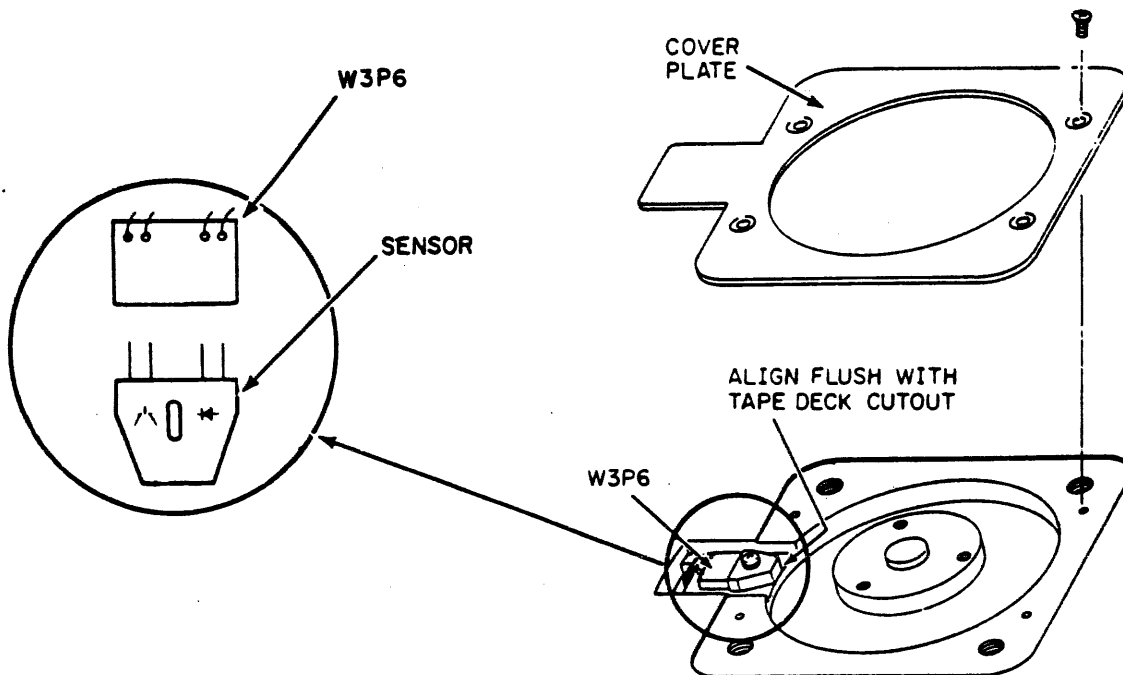

Figure 5-6. FILE PROTECT SENSOR ALIGNMENT

5.3.4 File Protect Sensor (Cont'd)

Replacement

NOTE

See Figure 5-6 for sensor alignment and cable plug connection.

1. Place the sensor on the tape deck and secure with the mounting screw and washer.
2. Attach connector W3P6 to the sensor pins.
3. Reinstall the sensor cover plate and secure it to the tape deck with four mounting screws.

Verification Checks

1. Thread a write-enabled tape and perform a load operation. Observe that the FILE PRO indicator is not lighted.
2. Unload tape and remove the write enable ring. Thread tape, perform a load operation, and observe that the FILE PRO indicator is lighted.

5.3.5 EOT/BOT Sensor Assembly

Removal

1. Remove the tape path cover and magnetic head cover from the tape deck.
2. Remove connector W3P1 from the EOT/BOT assembly.
3. Remove the flat head mounting screw from the assembly base-mount and lift the assembly from the tape deck. See Figure 5-7.

NOTE

The defective sensor must be replaced as a complete assembly.

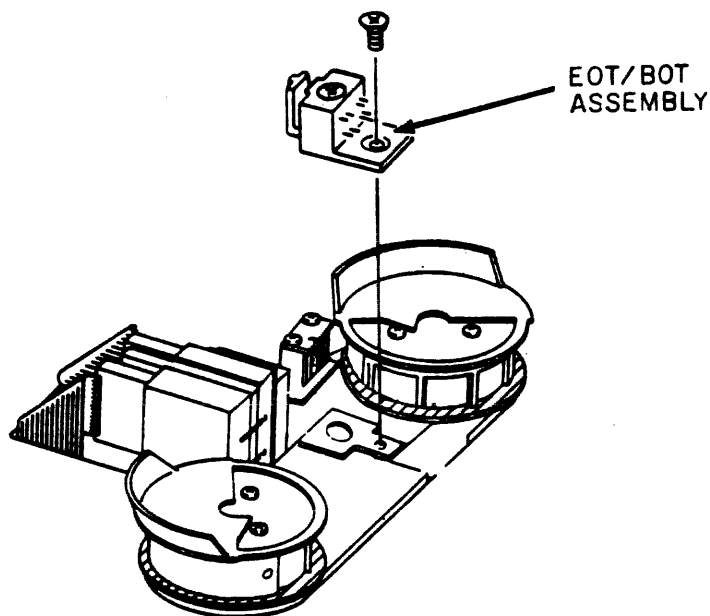

Figure 5-7. EOT/BOT SENSOR

Replacement

1. Position the EOT/BOT assembly onto the tape deck and install the flat head mounting screw.
2. Thread tape onto the take-up reel. Align the EOT/BOT assembly with the tape.

5.3.5 EOT/BOT Sensor Assembly

Replacement (Cont'd)

3. Tighten the flat head mounting screw.
4. Attach connector W3P1 to the assembly as shown. If excess cable exists, position the cable so that the excess is at the rear of the tape deck.
5. Install the magnetic head cover and the tape path cover.

Verification Checks

NOTE

If available, use a 600 foot reel of tape with properly installed EOT/BOT markers to reduce test time.

1. Load a reel of tape onto the supply hub and thread tape so that the BOT marker is located before the EOT/BOT assembly.
2. Perform a load operation and observe that the tape loads and positions itself at the BOT marker (the BOT indicator lights).
3. Execute Field Service Diagnostic Test #44 to verify the operation of the EOT sensor.

5.3.6 Take-Up Reel Hub Assembly

Removal

1. Remove the four mounting screws from the take-up reel hub cover and remove the cover from the hub assembly. See Figure 5-8.
2. Remove the three Allen screws, lockwashers and plain washers securing the reel to the motor shaft assembly.
3. Remove the take-up reel from the transport.

Replacement

CAUTION

If a new reel is being installed, inspect the reel edges for burrs or cracks that could cause tape damage.

1. Replace the take-up reel on the transport.
2. Replace the three Allen screws, lockwashers, and plain washers securing the reel to the motor shaft assembly.
3. Replace the cover on the hub assembly and install the four mounting screws.

Verification Checks

1. Manually rotate the tape reel to ensure that the reel does not contact the tape deck.
2. Load a known good reel of tape and observe the reel during tape motion. The tape should not contact the reel flanges.

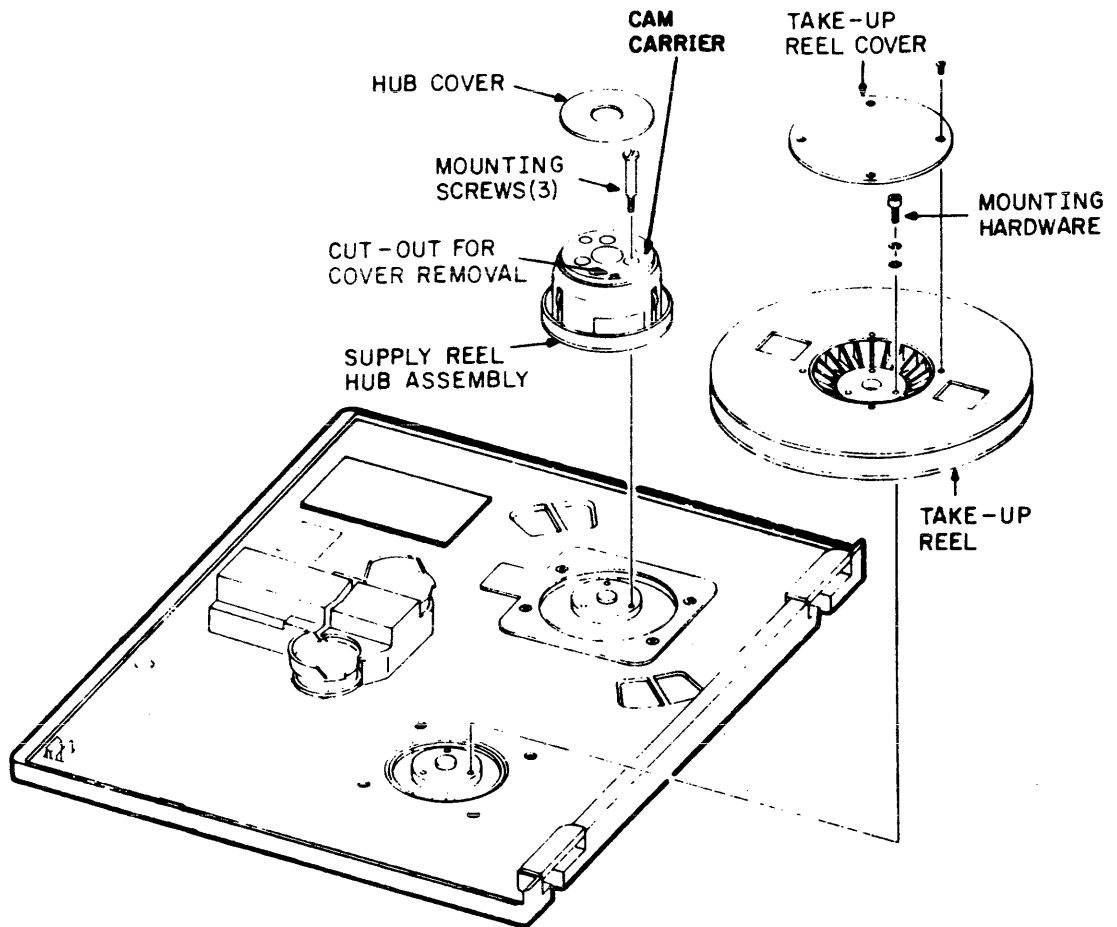

Figure 5-8. TAKE-UP REEL/SUPPLY REEL HUB ASSEMBLIES

5.3.7 Take-Up Reel Motor Assembly

Removal

1. Perform the Removal procedure for the Take-up Reel Hub Assembly (paragraph 5.3.6).
2. Place the tape deck in the maintenance position and remove the drive cover (paragraph 5.3.1).
3. Remove connector W3P2 from the tach assembly on the take-up motor.
4. Remove connector B3P1 from the Power Amplifier module (jack J1 on the power amplifier module).
5. Remove the four mounting screws securing the motor to the tape deck. See Figure 5-9. Remove the motor from the transport.

Replacement

NOTE

The reel motor and tach must be replaced as an assembly.

CAUTION

When installing the motor, make sure there are no loose wires between the motor mounting plate and tape deck.

1. Position the motor on rear of the tape deck so that the B3P1 cable extends from the lower right. Secure the motor with the four mounting screws.
2. Attach connector B3P1 to J1 on the Power Amplifier module.
3. Attach connector W3P2 to the tach assembly on the motor.
4. Install the drive cover and return the tape deck to the operating position.
5. Perform the Replacement procedure for the Take-up Reel Hub Assembly.

5.3.7 Take-Up Reel Motor Assembly (Cont'd)

Verification Check

1. Execute Field Service Diagnostic Test #37 (refer to TU81/TA81 Pathfinder for Diagnostic Test 37 requirements).
2. Execute Field Service Test #48.
3. Thread tape. Do not load. Execute Operator Diagnostic Test #01.

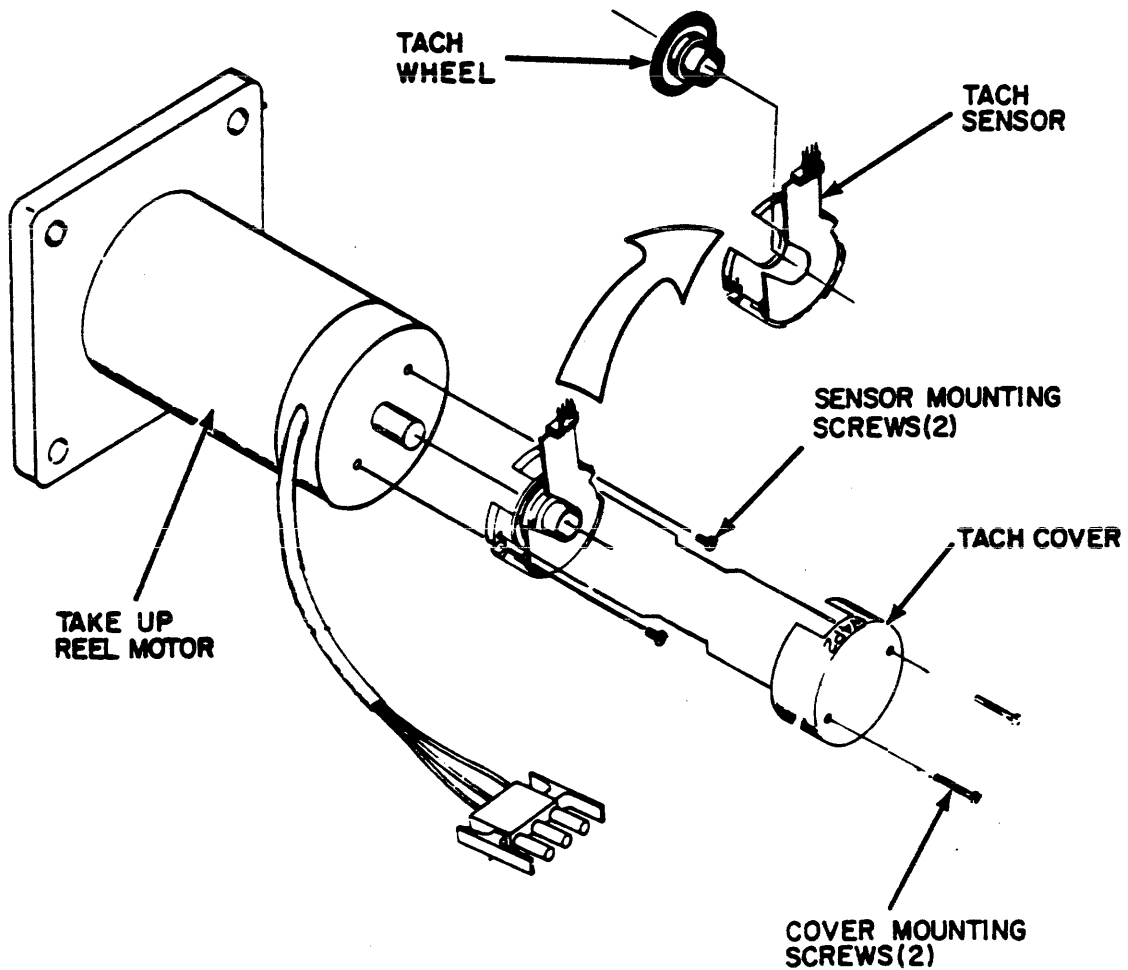

Figure 5-9. TAKE-UP MOTOR ASSEMBLY

5.3.8 Supply Reel Hub Assembly

Removal (Refer to Figure 5-8)

1. Press the center button on the hub to put the hub into the unlatched position.
2. Locate the slot opening on the periphery of the cover. Insert a small blade screwdriver into the slot and twist to unsnap the cover from the hub assembly.
3. Place the hub assembly in the latched position by pressing the cam carrier.

CAUTION

Make sure that the hub is latched before proceeding with further removal. If the hub is unlatched, parts may fall off.

4. Remove the three large shoulder screws from the cam carrier. The hub assembly can then be removed from the tape deck.

Replacement

1. Position the hub assembly onto the motor shaft assembly and secure with three large shoulder screws.
2. Install the cover on the face of the hub assembly.

Verification Checks

1. Mount the tape reel onto the hub assembly. The reel should mount easily onto the hub and against the bottom flange.
2. Latch the reel onto the hub. Make sure the reel is securely fastened.
3. Load a known good quality tape and observe the reel during tape motion. The tape should not contact the reel flanges.
4. Thread tape. Do not load. Execute Operator Diagnostic Test #01.

5.3.9 Supply Reel Motor Assembly

IMPORTANT

The supply reel motor assembly is not supplied as part of the spare parts list: the spared take-up reel motor assembly must be disassembled and the motor used as a replacement for the supply motor.

Removal

1. Perform the Removal procedure for the supply reel hub assembly (paragraph 5.3.8). Place the tape deck in the maintenance position and remove the drive cover (paragraph 5.3.1).
2. Remove connector B1P1 from J3 on the Power Amplifier module.
3. Remove the tach cover and mounting screws from the motor (Figure 5-10). Retain for reuse.
4. Remove connector W3P5 from the tach assembly on the motor.
5. Remove the four mounting screws securing the motor to the tape deck. Remove the motor from the tape deck.
6. Remove the mounting screw and the sensor from the mounting plate on the supply reel motor. See Figure 5-10. Retain for reuse.
7. Loosen the two set screws securing the tach to the motor shaft and remove the tach from the shaft. Retain for reuse.
8. Remove the four screws securing the mounting plate and remove the plate from the supply reel motor. Retain for reuse.

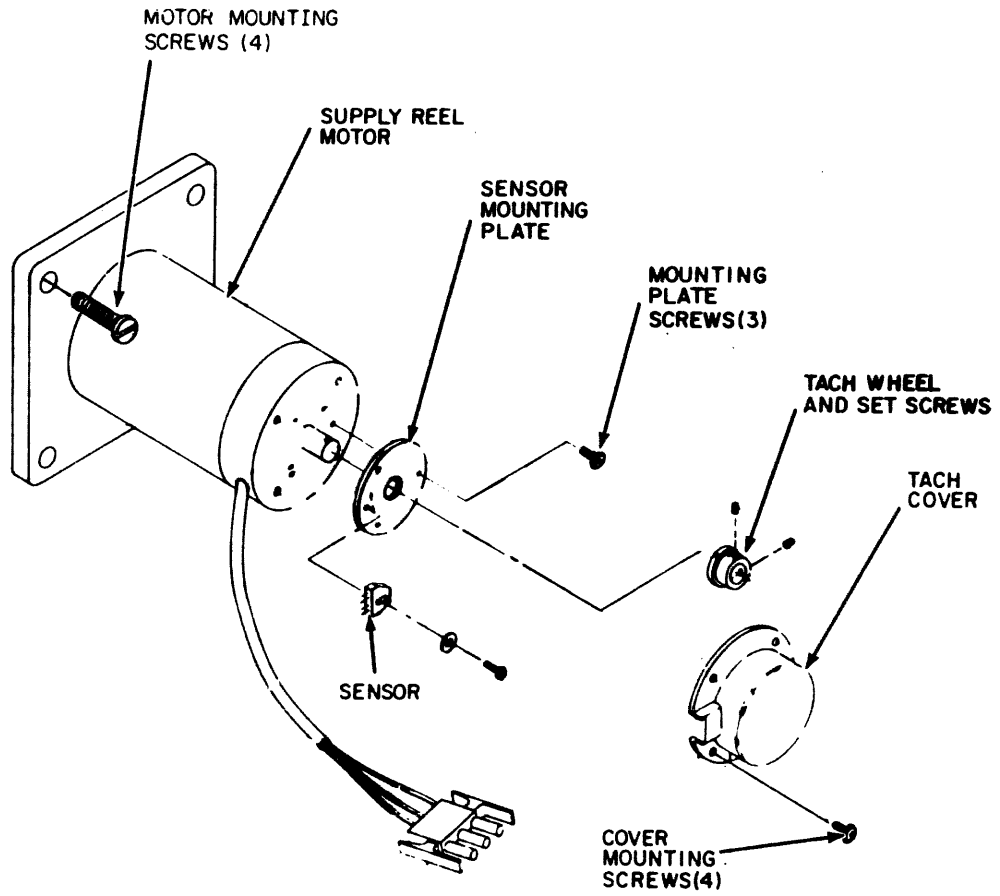

Figure 5-10. SUPPLY MOTOR ASSEMBLY

5.3.9 Supply Reel Motor Assembly

Removal (Cont'd)

9. Disassemble the spared take-up reel motor assembly as follows: (see Figure 5-9)
 - a. Remove the two mounting screws and the tach cover from the motor assembly.
 - b. Remove the two mounting screws securing the tach sensor to the reel motor. Remove the tach sensor from the reel shaft and the tach wheel.
 - c. Loosen the set screw and remove the tach wheel from the motor shaft.

Replacement

1. Place the mounting plate (from step 8 of Removal) onto the rear of the new motor and secure with four mounting screws.
2. Assemble the sensor and tach wheel (from steps 6 and 7 of Removal) onto the motor mounting plate and shaft as shown in Figure 5-11 and adjust per paragraph 5.3.10 of Replacement.

CAUTION

When installing the new motor, make sure there are no loose wires between the motor mounting plate and tape deck.

3. Position the motor on the rear of the tape deck so that the B1P1 cable extends from the right. Secure the motor with four mounting screws.
4. Attach connector B1P1 to J3 on the Power Amplifier module.
5. Attach connector W3P5 to the tach sensor pins as shown in Figure 5-11.
6. Install the tach cover and secure with the four mounting screws.

5.3.9 Supply Reel Motor Assembly (Cont'd)

Replacement (Cont'd)

7. Install the drive cover and return the tape deck to the operating position.
8. Perform the Replacement procedure for the Supply Reel Hub Assembly.

Verification Check

1. Thread tape. Do not load. Execute Operator Diagnostic Test #01.

.3.10 Supply Motor Tach and Sensor

Removal

1. Place the tape deck in the maintenance position and remove the drive cover (paragraph 5.3.1).
2. Remove four mounting screws and the tach cover from the supply motor. See Figure 5-10.
3. Remove connector W3P5 from the sensor pins.
4. Remove the mounting screw and the sensor from the mounting plate.
5. Loosen the two set screws securing the tach to the motor shaft and remove the tach.

Replacement (See Figure 5-11)

1. Insert the tach wheel on the motor shaft. Position the tach for a 0.030 ± 0.005 inch clearance between the tach and the sensor mounting plate.
2. Install the sensor on the mounting plate and position for a clearance of 0.150 ± 0.01 inch between the sensor and the tach. Tighten the sensor mounting screw.

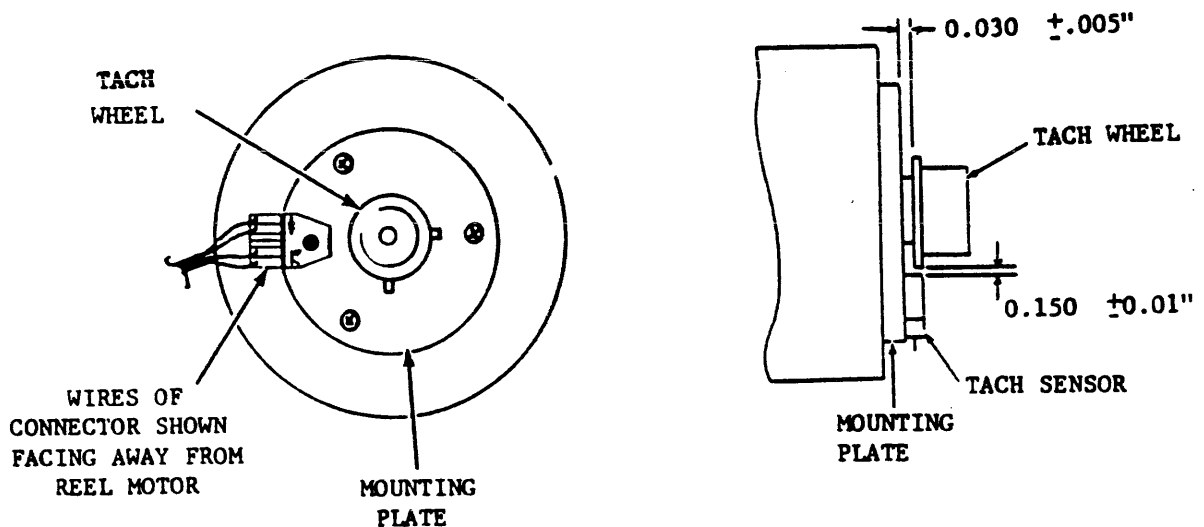

Figure 5-11. TACH WHEEL/SENSOR ALIGNMENT

5.3.10 Supply Motor Tach and Sensor

Replacement (Cont'd)

3. Attach connector W3P5 to the sensor pins.
4. Install the tach cover and secure with the four mounting screws.
5. Replace the drive cover and return the tape deck to the operating position.

Verification Check

1. Thread tape. Do not load. Execute Operator Diagnostic Test #01.

5.3.11 Air Bearing Sensors

Removal

NOTES

Replacement parts for the air bearing assembly are contained in Refurbishment Kit P/N 29-24359. This kit contains a supply air bearing spring guide, a take-up air bearing spring guide, a sensor, a small O ring, and a large O ring. If a sensor is replaced, it is recommended that the appropriate spring guide and both O rings also be replaced.

The supply air bearing spring guide and the take-up air bearing spring guide are not interchangeable.

1. Perform steps 1 thru 6 of paragraph 5.3.19 (Write Driver/Read Amplifier/Servo Control Modules Removal).
2. Remove connector P1 from the sensor pins.
3. To gain access to the screws holding the air bearing, remove the screws holding the logic cage and move the cage enough to access the air bearing mounting screws. See Figure 5-12. DO NOT remove the tie-wraps holding the cables to the cage.
4. Remove the mounting screws and washers from the air bearing assembly (the tape path cover on the top of the tape deck will hold air bearings in place at this time).

CAUTION

Take care not to snag or chafe the control panel cable or any other cable when positioning the tape deck.

5. Return the tape deck to the operating position.
6. Remove the tape path cover and lift the air bearings away from the tape deck.

5.3.11 Air Bearing Sensor

Removal (Cont'd)

7. Remove the O ring from the air bearing housing. See Figure 5-13.
8. Remove the two socket head screws and washers securing the sensor to the rear of the air bearing. Remove the sensor and the small O ring from the bearing housing.
9. Replace the spring guides as described in paragraph 5.3.12.

Replacement

1. Insert a new small O ring in the opening at the rear of the sensor.
2. Position the sensor on the air bearing so that the connector pins are positioned towards the outside of the air bearing. Secure the sensor with the mounting screws and washers.

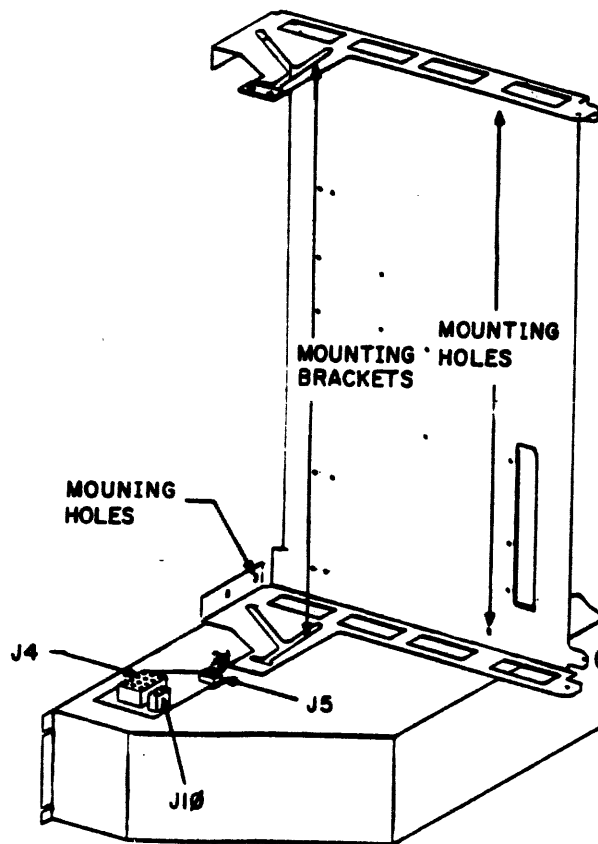

Figure 5-12. LOGIC CAGE

5.3.11 Air Bearing Sensor

Replacement (Cont'd)

3. Insert the large O ring into the aperture at the rear of the air bearing housing.
4. Place the air bearing assembly onto the tape deck using locating pin for positioning. Install the tape path covers to hold the air bearings in position.
5. Place the tape deck in the tilted maintenance position. Secure the air bearings with mounting screws and washers.
6. Replace the screws the holding logic cage. See Figure 5-12.
7. Attach connector P1 to the sensor pins. See Figure 5-11 for pin orientation.
8. Perform steps 4 through 9 of paragraph 5.3.19 (Write Driver/Read Amplifier/Servo Control Modules Replacement).

Verification Check

1. Thread tape. Do not load. Execute Operator Diagnostic Test #01.

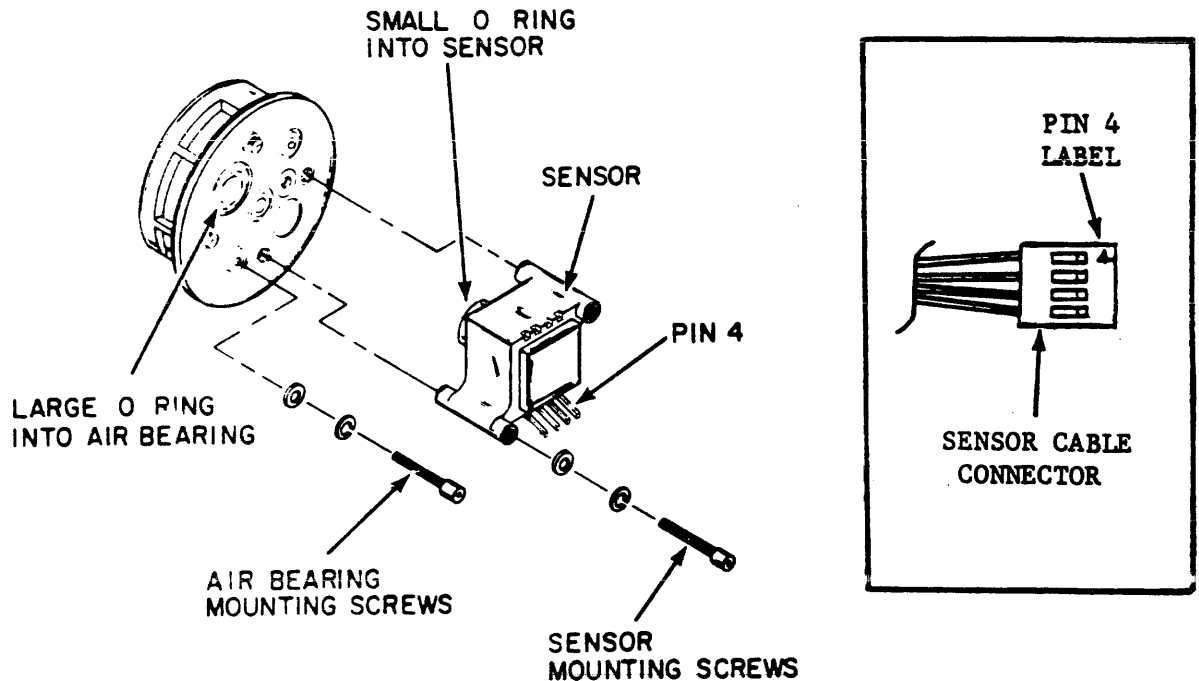

Figure 5-13. AIR BEARING SENSORS

02A02-76

5.3.12 Supply and Take-Up Air Bearing Spring Guide

Removal

NOTE

Replacement parts for the air bearing assembly are contained in Refurbishment Kit P/N 29-24359. This kit contains a supply air bearing spring guide, a take-up air bearing spring guide, a sensor, a small O ring, and a large O ring. If a spring guide is being replaced, it is recommended that both the supply air bearing spring guide and the take-up air bearing spring guide be replaced.

1. Remove the tape path cover and the magnetic head cover from the tape deck.
2. Remove the two phillips head screws securing the supply spring guide, isolator, and the guard to the bearing housing. See Figure 5-14.
3. Remove the spring guard, isolator, and the guide from the housing.
4. Repeat steps 2 and 3 to remove the take-up spring guide.

Replacement

1. Place the supply rear spring guide (P/N 77004255), isolator, and the guard into the bearing housing. Holes for the mounting screws provide positive alignment of both parts to the housing.
2. Secure the guide with two phillips head screws.
3. Repeat steps 1 and 2 above using spring guide (P/N 77004254) to replace the take-up spring guide.
4. Install the tape path cover and magnetic head cover on the tape deck.

5.3.12 Air Bearing Spring Guide (Cont'd)

Verification Checks

1. Thread tape. Do not load. Execute Operator Diagnostic Test #01.
2. Visually observe the tape edge for no damage.

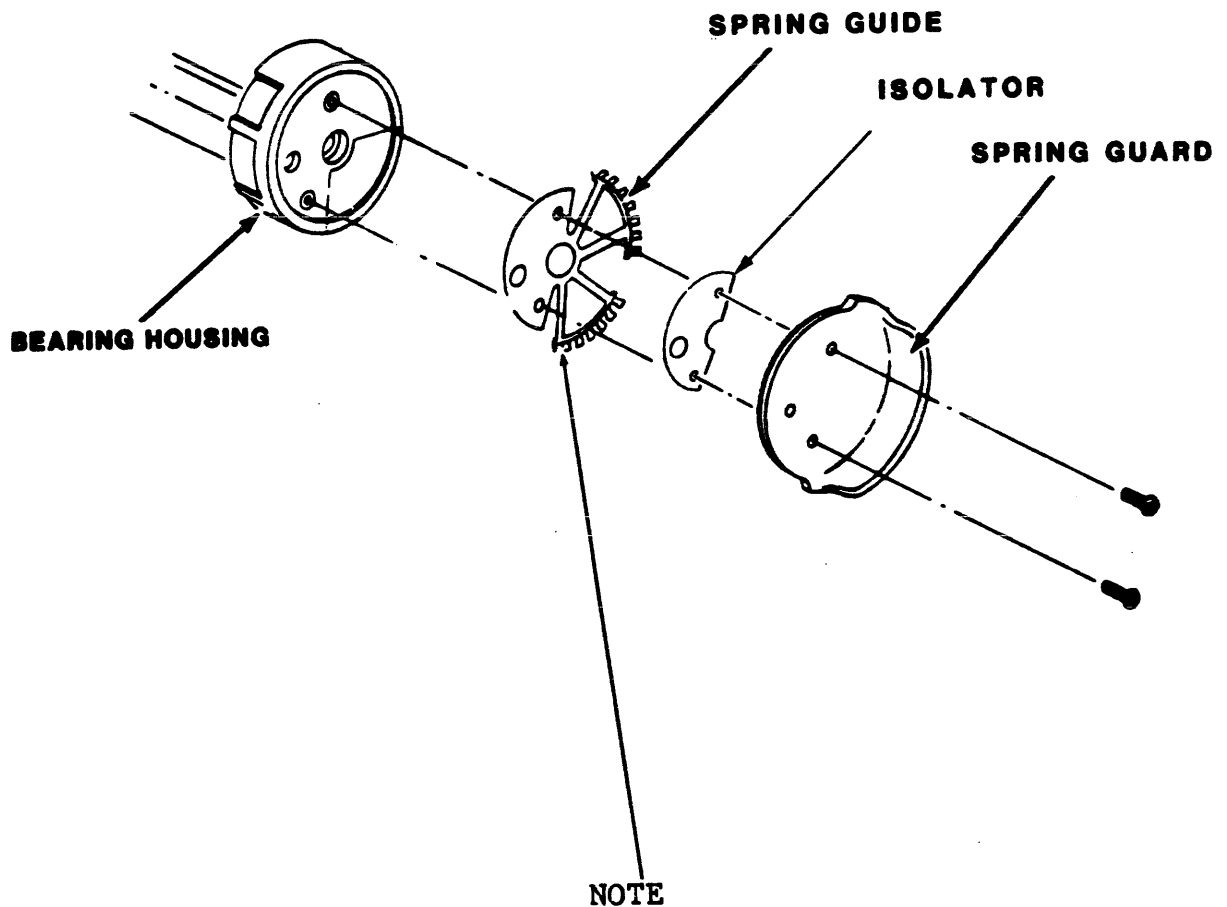

The supply spring guide and the take-up spring guide are not interchangeable.

Figure 5-14. AIR BEARING SPRING GUIDE

5.3.13 Pneumatic Pump Assembly

Removal

1. Place the tape deck in the maintenance position and remove the drive cover (paragraph 5.3.1).
2. Detach the two pneumatic tubes from the filter box assembly. See Figure 5-15.
3. Remove the drive cover to access the pneumatic pump (paragraph 5.3.1).
4. Remove connector W4P2 from the power supply.
5. Remove the pneumatic tube connected from the tape deck nipple to the pneumatic pump.

NOTE

Detach any wiring that may interfere with removal of the pneumatic pump assembly.

6. Remove the four mounting screws and washers securing the pneumatic assembly to the tape deck. Carefully withdraw the assembly from the transport.

Replacement

1. Position the pneumatic pump assembly to the rear of the tape deck and secure with washers and mounting screws.
2. Attach the pneumatic tubes from the compressor to the tape deck nipple.
3. Attach connector W4P2 to the power supply. Attach any wiring that was disconnected prior to the Removal procedure.
4. Install the drive cover and attach the two pneumatic tubes to the filter box assembly.

5.3.13 Pneumatic Pump Assembly (Cont'd)

Verification Check

1. Thread tape. Do not load. Execute Operator Diagnostic Test #01.

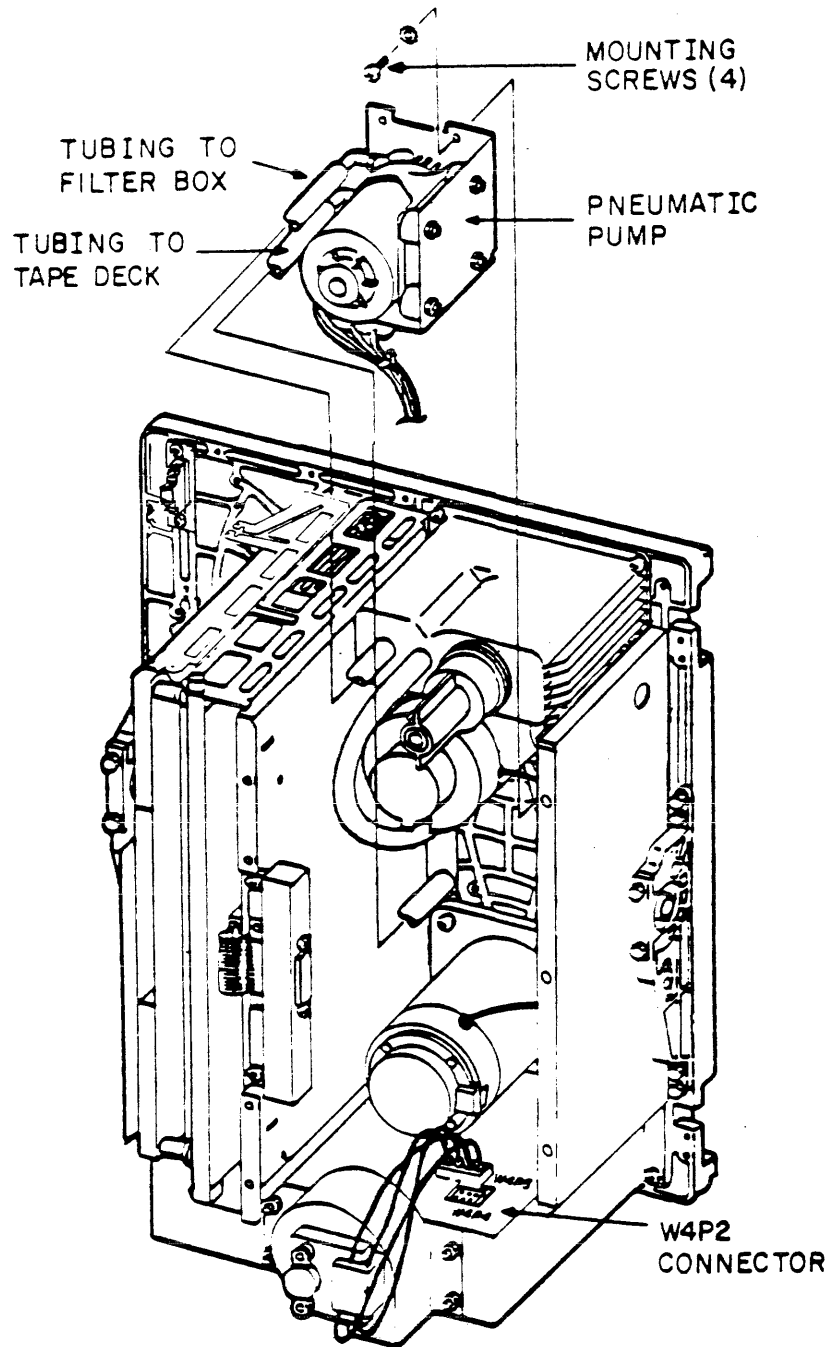

Figure 5-15. PNEUMATIC PUMP ASSEMBLY

5.3.14 Pressure Regulator and Filter Assembly

Removal

CAUTION

Replace filters only when necessary. It should not be replaced on a PM schedule. Air pressure could be lost through the seals when removing and replacing the filter assembly.

NOTE

If only the pressure regulator is being replaced, perform Removal steps 1 and 2, Replacement steps 4 and 5, and the Verification Check. If the filter is being replaced, perform the entire Removal/Replacement and Verification Check procedures.

1. Place the tape deck in the maintenance position (paragraph 5.2) and remove the drive cover (paragraph 5.3.1).
2. Remove the pressure regulator by unscrewing the regulator from the filter box assembly. See Figure 5-16.
3. Remove the two pneumatic tubes from the IN and OUT nipples on the filter box.
4. Remove the four mounting screws securing the filter box and remove the filter box from the tape deck.
5. Remove the filter from the filter box.

Replacement

1. Position the filter into the filter box.
2. Secure the filter box to the tape deck with the four mounting screws. Check seals for leaks.
3. Install the two pneumatic tubes on IN and OUT nipples.
4. Screw the pressure regulator clockwise onto the filter box assembly.
5. Replace the drive cover and return the tape deck to the operating position.

Verification Check

1. Thread tape. Do not load. Run Operator Diagnostic Test 01.

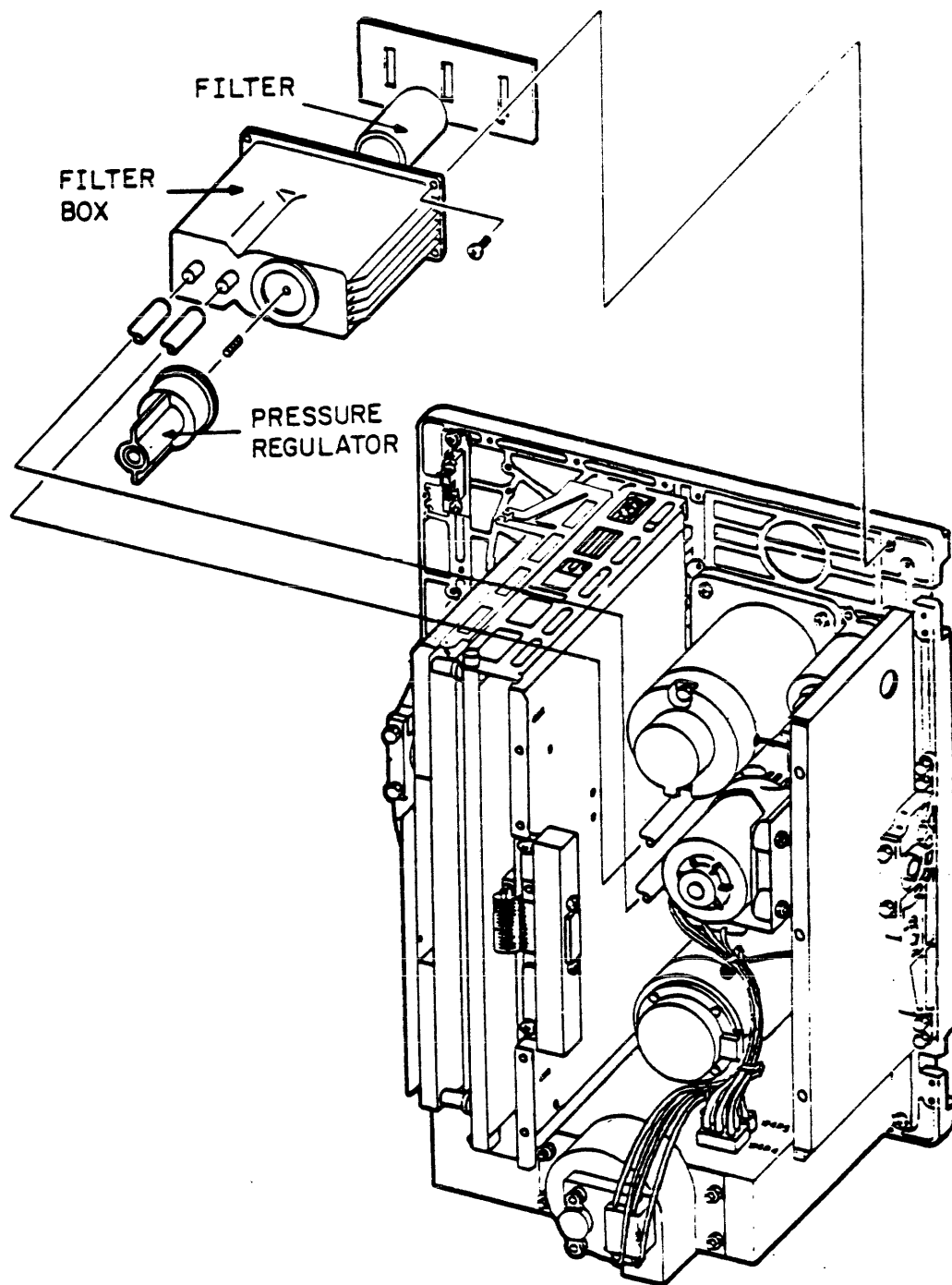

Figure 5-16. FILTER BOX ASSEMBLY

5.3.15 Magnetic Head Assembly

Removal

1. Remove the tape path cover and the magnetic head cover from the tape deck.
2. From the top of the transport, detach read head connector W6P1, write head connector W5P1, and erase head wires P3/P4 from the magnetic head. See Figure 5-18.

NOTE

Before removing the head, tape a piece of soft material across the recording surface.

3. Perform steps 1 through 4 of paragraph 5.3.19 (Write Driver/Read Amplifier/Servo Control Modules, Removal).
4. From the rear of the tape deck, remove the read, write and erase connectors away from the magnetic head.

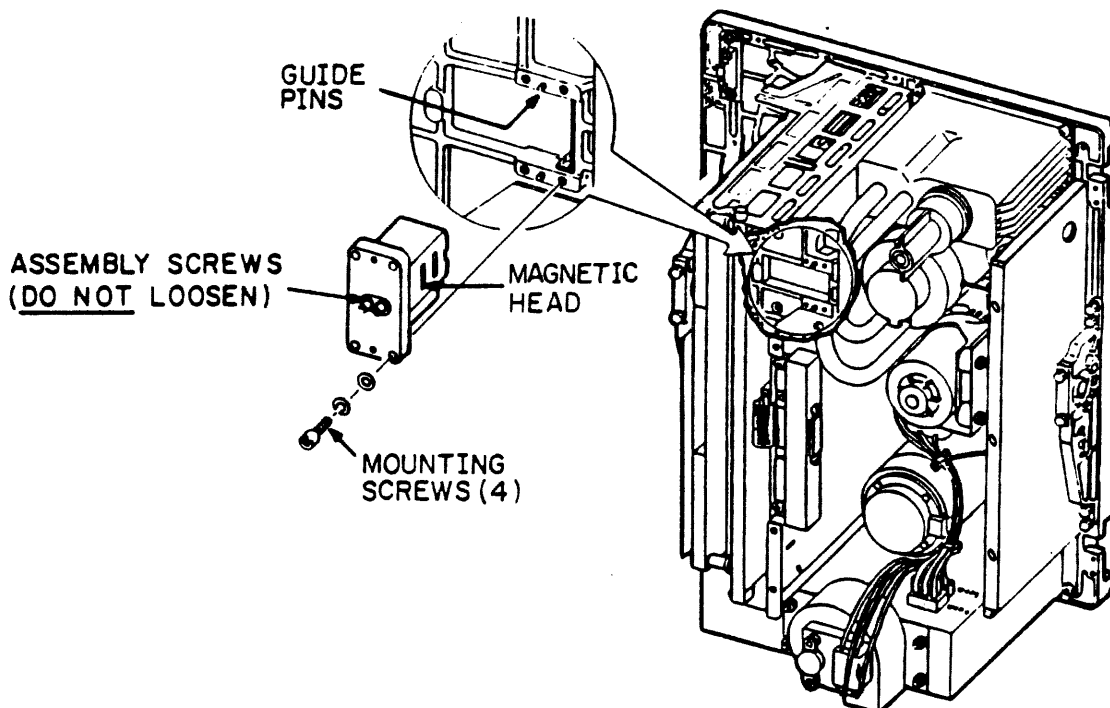

Figure 5-17. MAGNETIC HEAD ASSEMBLY

5.3.15 Magnetic Head Assembly

CAUTION

Refer to Figure 5-17 for the location of the head mounting screws. DO NOT loosen the head assembly screws; if loosened, the entire head must be replaced by a new assembly.

Removal (Cont'd)

5. Loosen the four head mounting screws. Hold the head against the tape deck while removing the four mounting screws, lockwashers, and flatwashers.
6. Carefully withdraw the magnetic head from the tape deck.

Replacement

NOTE

Before installing the magnetic head, ensure that the recording surface is protected with a soft material.

1. Place the magnetic head on the tape deck and position the guide pins into the head.
2. While holding the head in place, insert the flatwashers, lockwashers, and mounting screws. Tighten the four mounting screws.
3. Place the read and the write/erase cables through the tape deck.
4. From the top of the tape deck, attach the read, write and erase connectors to the magnetic head. See Figure 5-18. Remove the recording surface covering.
5. Perform steps 6 through 9 of paragraph 5.3.19 (Write Driver/Read Amplifier/Servo Control Modules Replacement).
6. Install the tape path cover and the magnetic head cover on the tape deck.

5.3.15 Magnetic Head Assembly (Cont'd)

Verification Checks

1. Clean the magnetic head recording surface with a soft lint-free cloth moistened with tape transport cleaner. Wipe the recording surface in same direction as tape motion.
2. Load a 3M777, or equivalent, write-enabled tape.
3. Move jumper W1 at location D23 on the Servo-Control module to the 1-2 position.
4. Execute Field Service Test 64 to set write current values.

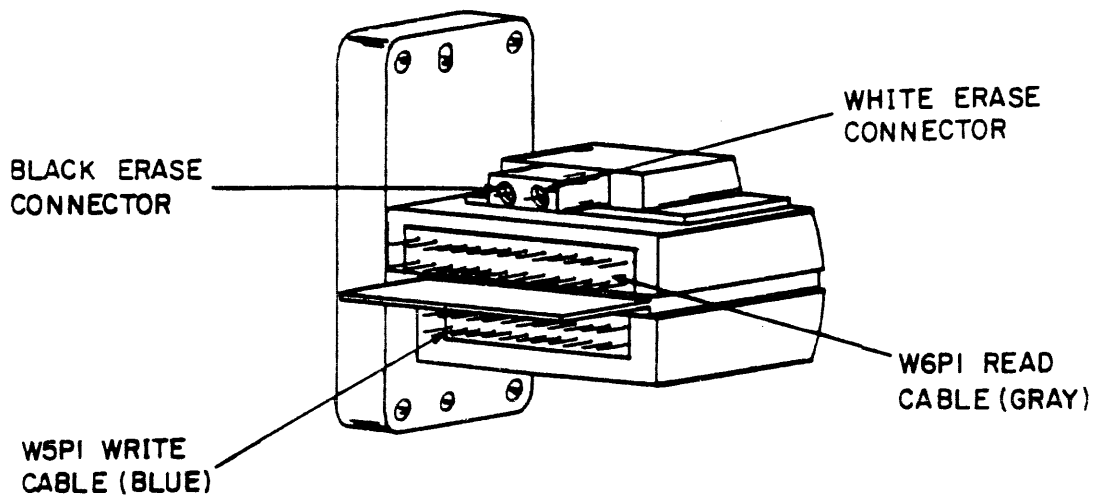

02A01-81

Figure 5-18. MAGNETIC HEAD CONNECTORS

5.3.15 Magnetic Head Assembly

Verification Checks (Cont'd)

5. Execute Field Service Diagnostic Test #31. The test will complete with display 00.
6. Return jumper W1 at location D23 on the Servo/Control Module from the 1-2 position to the 2-3 position before the unit is powered down.
7. Thread tape. Do not load. Execute Operator Test #01. If the test is successful, the test terminates with display 00. If the test is unsuccessful, refer the display number to corresponding Fault Code in the TU81/TA81 Pathfinder.

5.3.16 Control Panel Assembly

Removal

1. Open the front cabinet door.
2. Remove connectors W13J1, W8P1, and W16P2 from the control panel.
3. Remove the four mounting screws from the control panel bracket and the ground strap connector from the door assembly.
4. Move the bracket away from the door assembly (FAULT switch and +5V cable still attached).
5. Remove the push-in clips (see Figure 5-19) securing the control panel to the mounting bracket.
6. Remove the control panel.

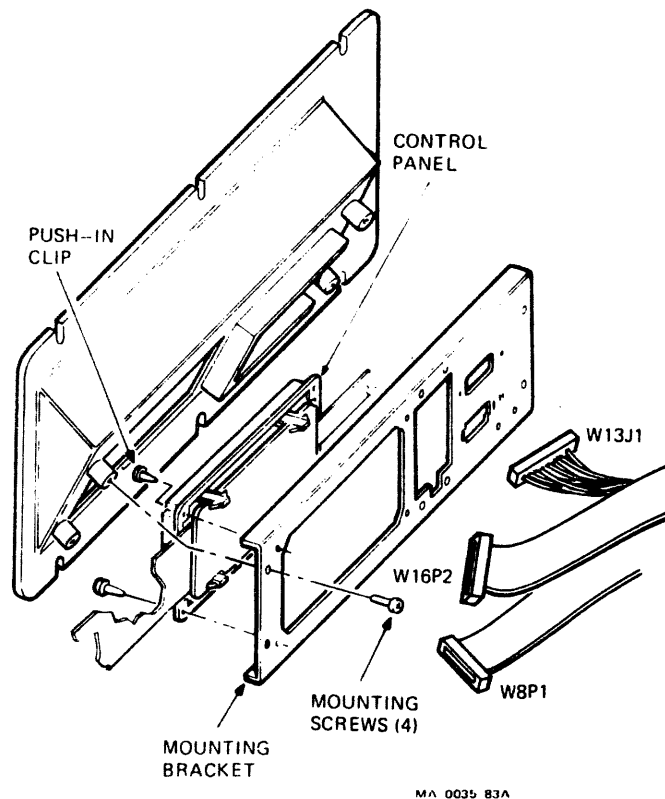

Figure 5-19. CONTROL PANEL ASSEMBLY

5.3.16 Control Panel Assembly (Cont'd)

Replacement

1. Install small connector W13J1 and align the mounting holes in the control panel with the holes in the bracket. Secure control panel with four push-in clips.
2. Place the control panel and bracket in position on the door assembly and install the four mounting screws. Attach the ground strap to the door assembly.
3. Install connectors W8P1 and W16P2 to the control panel assembly.

Verification Check

1. Thread tape. Do not load. Execute Operator Diagnostic Test #01.

5.3.17 Cooling Fan Assembly

Removal

1. Place the tape deck in the maintenance position. Remove the drive cover (paragraph 5.3.1) and detach the cooling fan connector from receptacle J3 on the power supply (Figure 5-20).
2. Remove the four hex nuts and washers and withdraw the fan assembly from the mounting studs.

Replacement

1. Place the fan on the mounting studs and install the four hex nuts and washers. Attach the cooling fan connector to receptacle J3 on the power supply.
2. Replace the drive cover. Place the tape deck in the operating position.

Verification Check

1. Power the transport on and check for air flow from fan.

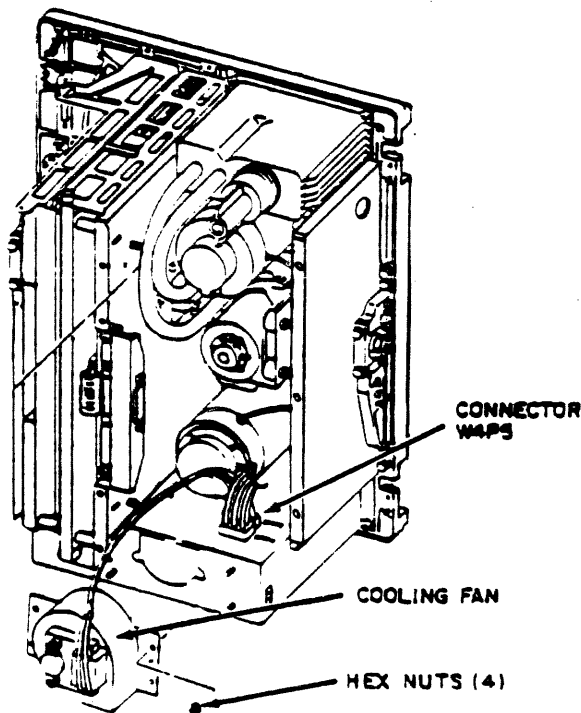

Figure 5-20. COOLING FAN ASSEMBLY

5.3.18 Power Supply

Removal

1. Disconnect the power cable from the power supply. See Figure 5-22.
2. Tilt the tape deck into the maintenance position (paragraph 5.2).
3. Remove the cooling fan assembly (paragraph 5.3.17).
4. Detach all connectors from power supply. See Figure 5-21.
5. Place the tape deck in the operating position.

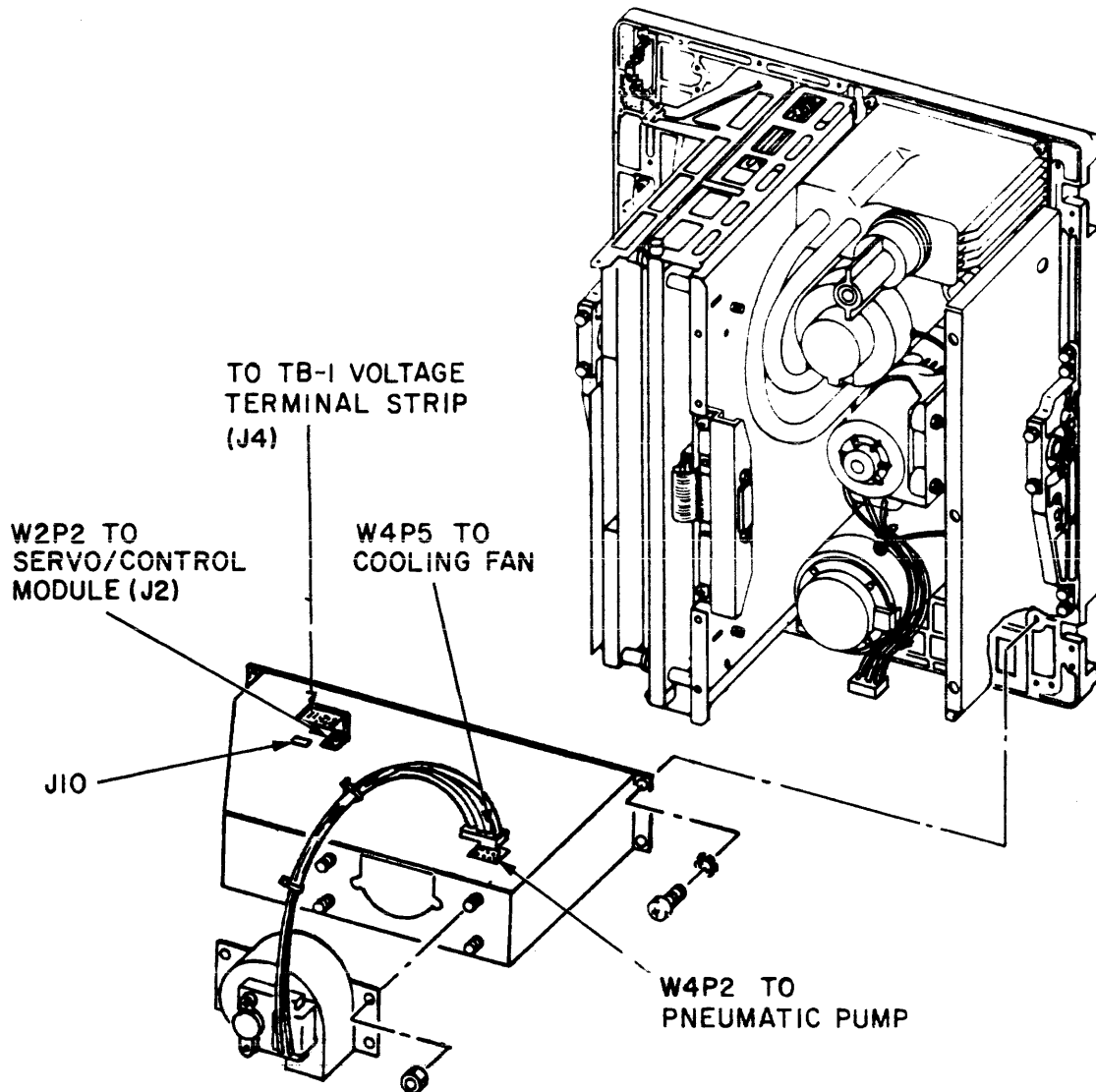

Figure 5-21. POWER SUPPLY CONNECTORS

5.3.18 Power Supply

Removal (Cont'd)

6. Open the rear door of the cabinet.
7. Remove the frame stabilizing bar by removing the mounting screws. See Figure 5-22.

CAUTION

The power supply is attached to the tape deck by four screws. The two screws on the left are located in slots so that power supply can be slid out from under these screws for removal.

The power supply weighs approximately 4.1 Kg (9 lbs.).

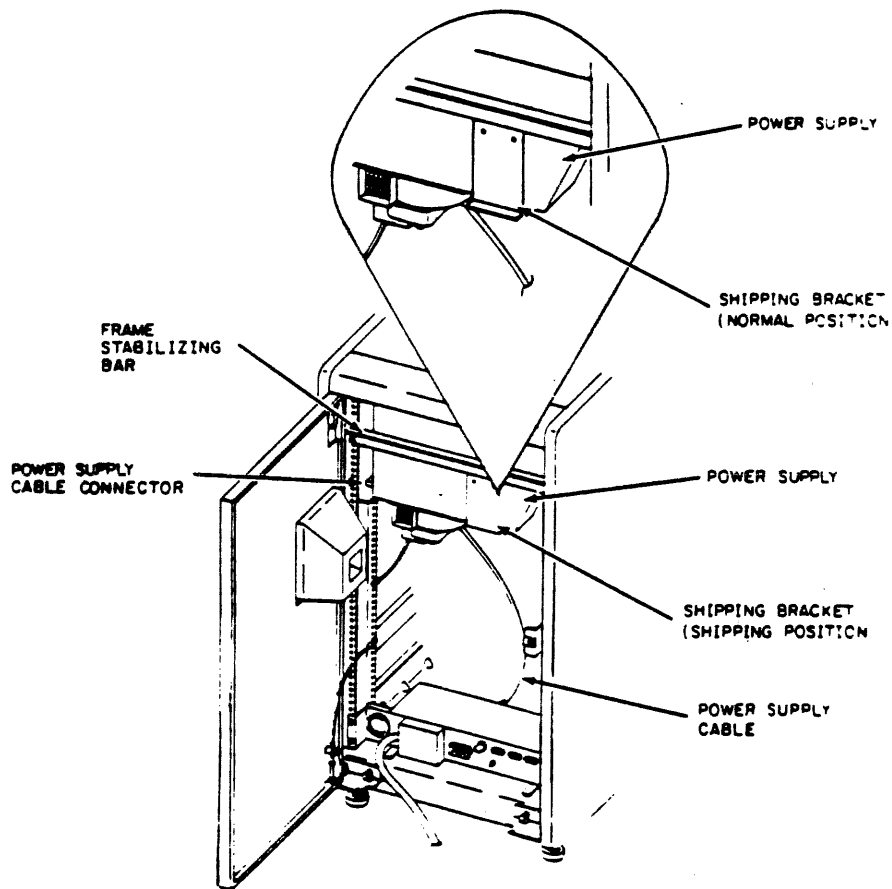

Figure 5-22. POWER SUPPLY (REAR CABINET VIEW)

5.3.18 Power Supply

Removal (Cont'd)

8. Loosen, but DO NOT REMOVE, the two mounting screws on the left side of the power supply.
9. Remove the two mounting screws on the right side of the power supply while supporting the power supply from the bottom.
10. Slide the power supply out of the slots on the left, and carefully remove the power supply from the cabinet.

Replacement

NOTE

If a new power supply is being installed, remove the cover and observe the position of the Voltage Select Card. See Figure 5-23. The position of this card must correspond to the input voltage defined on the equipment identification plate. The ends of the card are stencilled with "120V" and "220V" and indicating arrows. Make sure the card is connected to match the input voltage.

The card can be disconnected, turned upside down, and reconnected to the Main Power Supply module if required.

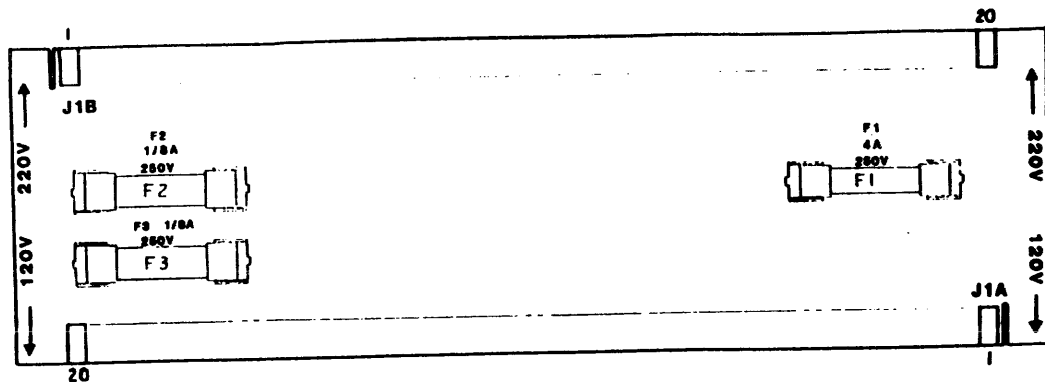

Figure 5-23. VOLTAGE SELECT CARD

5.3.18 Power Supply

Replacement (Cont'd)

1. From the rear of the transport, position the mounting slots on the left side of the power supply under the two loosened mounting screws.
2. Insert and tighten the two mounting screws on the right side of the power supply.
3. Tighten the two mounting screws on the left side.
4. Install the frame stabilizing bar and secure it with the mounting screws. Close the rear cabinet door.
5. Tilt the tape deck into the maintenance position.
6. Attach the connectors to the power supply as follows:

<u>POWER SUPPLY</u>	<u>CABLE</u>
J2	W4P2 Pneumatic Pump
J3	P1 Cooling Fan
J4	W7P1 TB1 Terminal Block
J5	W2P2 Servo/Control Module
J10	TB1 Terminal Block

7. Install the cooling fan assembly (paragraph 5.3.17).
8. Place the tape deck in the operating position.
9. Connect the power cable to the power supply.

Verification Checks

1. DC Voltage Checks - Using a digital voltmeter for all DC voltage measurements, connect the ground lead of the meter to pin 5 of the power terminal strip TB-1. See Figure 5-24. Connect the other meter lead to the points listed to test all DC voltages.

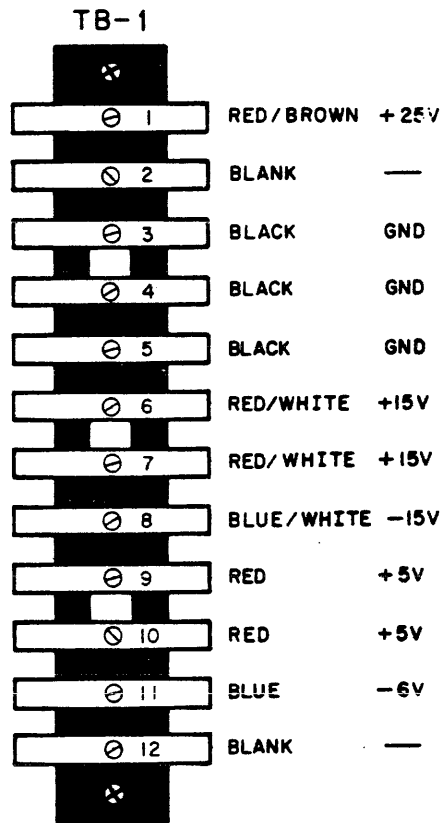

Figure 5-24. POWER TERMINAL STRIP TB-1

5.3.19 Write Driver/Read Amplifier/Servo Control Modules

NOTE

To service any of these modules, you must separate them from the logic cage and move them to the maintenance position (Figures 5-25 and 5-26). Refer to Chapter 5 of the TU81/TA81 Subsystem User Guide (EK-TUA81-UG) for instructions on removing the shipping and safety brackets.

CAUTION

Ensure that there is no undue stress placed on the wires or modules when removing the connectors.

Removal

1. Place the tape deck in the tilted maintenance position (paragraph 5.2).
2. Completely loosen both thumbwheels (top and bottom) to partially release the modules from the logic cage (Figure 5-26). Remove connectors W5P2 (to read/write head), W7P6, and W12P1 from the Write Driver Module (Figure 5-27).
3. Swing the modules slightly to the left. Remove both connectors (W7P5, W7P4) at the top of the Read Amplifier and Servo Control Modules (Figure 5-28).
4. Release the logic cage latch at the top-rear of the logic cage and temporarily slide the three-module assembly into the maintenance position (Figures 5-25 and 5-26).
5. From the Servo Control Module, remove connectors W3P8, W10P1, W8P1, and W2P1 (Figure 5-29). Remove connectors W6P2 (to read/write head), W12P2, and W12P3 from the Read Amplifier Module (Figure 5-28).
6. Ensure that all connectors have been removed. Remove one of the two Phillips screws from the bracket stop on the underside of the logic cage (Figure 5-26) and carefully remove the three-module assembly from the transport.

5.3.19 Write Driver/Read Amplifier/Servo Control Modules

Removal (Cont'd)

7. Remove the retaining bar from the logic cage (Figure 5-26).
8. Remove the read amplifier/write driver/servo control set of modules from the cage and the cabinet.
9. Remove the plastic clips at the top and bottom of the modules.
10. Loosen the upper thumbscrews 6 to 8 times at the top and bottom space brackets/blocks (Figure 5-26).
11. If you need to replace the Read Amplifier or Write Driver module, separate them by removing four standoff screws (Figures 5-27 and 5-28).
12. If you need to replace the Servo Control or Read Amplifier module, loosen the thumbscrews on the Read Amplifier module at J2/J9 and J3/J8 (Figure 5-28). Then slide the module to be replaced out of the brackets and separate the modules.

CAUTION

Avoid excessive stress on the boards by loosening the thumbscrews alternately and separating J2 from J9 and J3 from J8 as the screws are released.

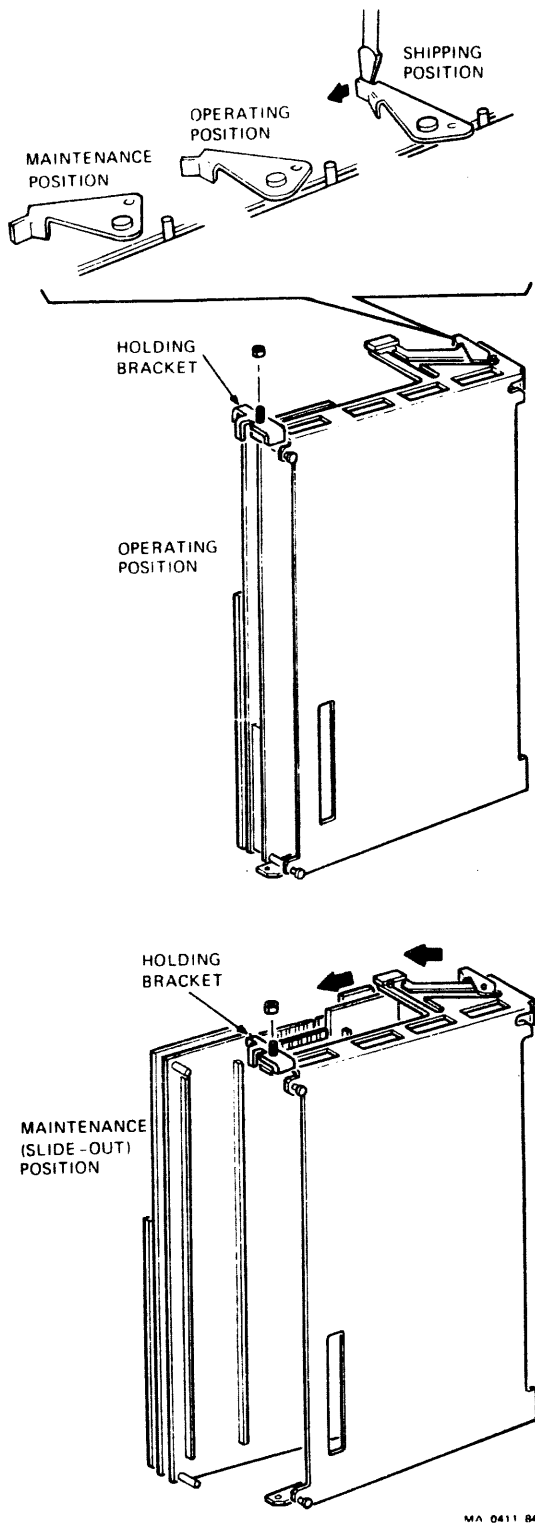

Figure 5-25. WRITE DRIVER/READ AMP/SERVO CONTROL LOGIC CAGE

1. TOP THUMBSCREW (TOP AND BOTTOM HINGES) BACK OUT TO REMOVE READ AMPLIFIER MODULE.
2. BOTTOM THUMBSCREW (TOP AND BOTTOM HINGES) BACK OUT TO REMOVE SERVO CONTROL MODULE.

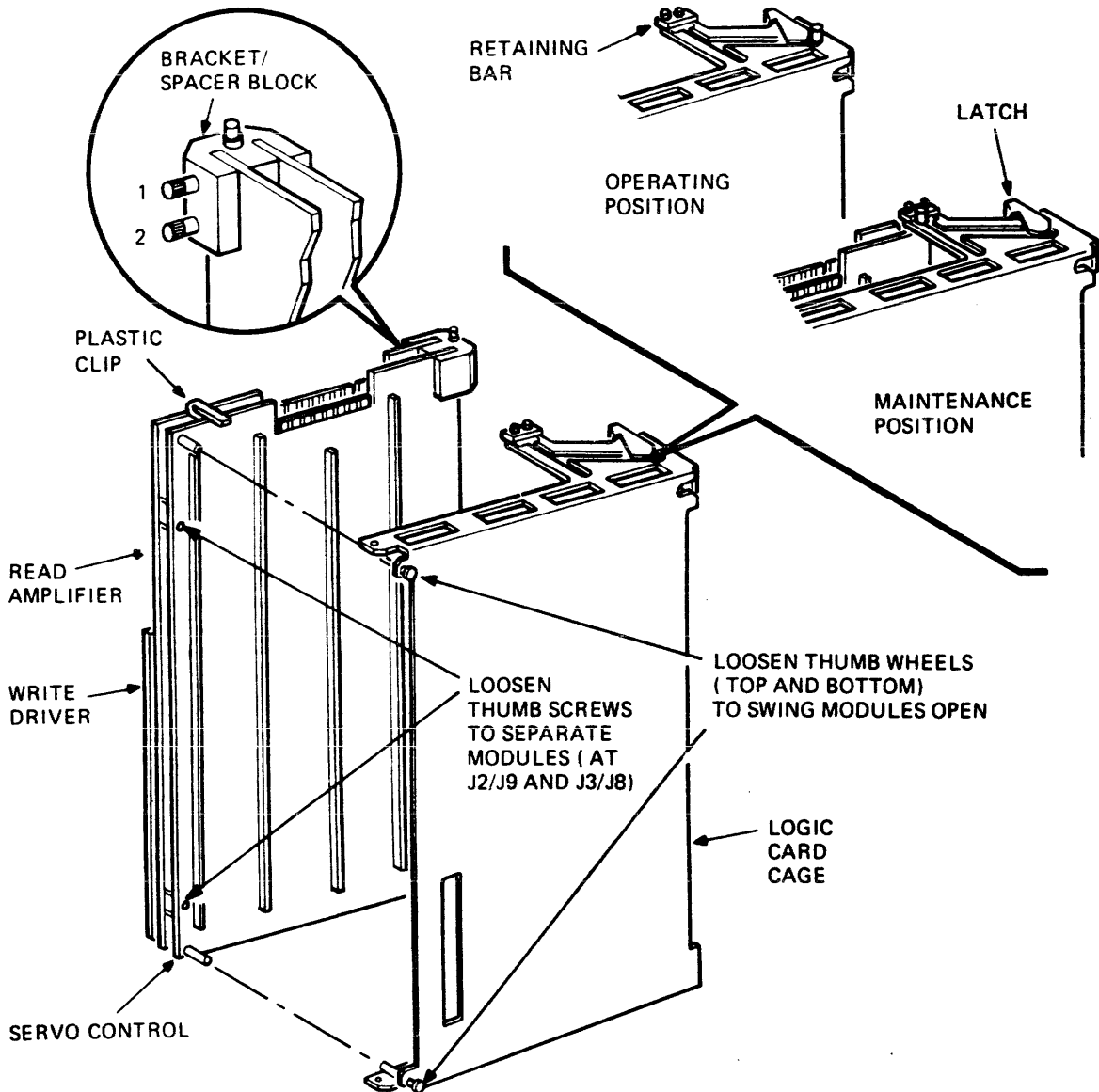

Figure 5-26. REMOVING WRITE DRIVER/READ AMP/
SERVO CONTROL MODULES

5.3.19 Write Driver/Read Amplifier/Servo Control Modules

Replacement

NOTE

It is recommended that the modules be replaced together as one assembly into the unit. This procedure assumes the above mentioned modules have been previously removed and subsequently separated.

1. Join the Read Amplifier and Servo Control Modules and partially secure by installing and tightening two thumbscrews as shown in Figures 5-28 and 5-29.
2. Install an upper and lower spacer block assembly to both modules and secure by tightening each (4) thumbscrew (Figure 5-26). Replace the plastic clips.
3. Secure the Write Driver Module to the read amplifier using four screws (Figures 5-27 and 5-28).
4. Carefully install the three modules (as in assembly) into the transport and place into the maintenance position.
5. Install connectors W6P2 (from read/write head), W12P2, and W12P3 to the Read Amplifier Module (Figure 5-28). At the Servo Control Module, install connectors W3P8, W10P1, W8P1, and W2P1 (Figure 5-29). Install the read/write head cables.
6. Install connectors W7P5 and W7P4 to the top of the Read Amplifier and Servo Control Modules (Figure 5-28). Slide the module assembly into the operating position and secure with the logic cage latch (Figures 5-25 and 5-26).
7. Replace and secure the retaining bar (Figure 5-26).
8. Install connectors W5P2 (from read/write head), W7P6, and W12P1 on the Write Driver Module.
9. Tighten the upper and lower thumbwheels on the logic cage to completely secure the modules (Figure 5-26).
10. Place the tape deck in the operating position (paragraph 5.2).

NOTE

Some versions of the TU81's module assembly use only two screws to secure the write driver module to the read amplifier module. The other two screws have been replaced with plastic clips mounted on the read amplifier module.

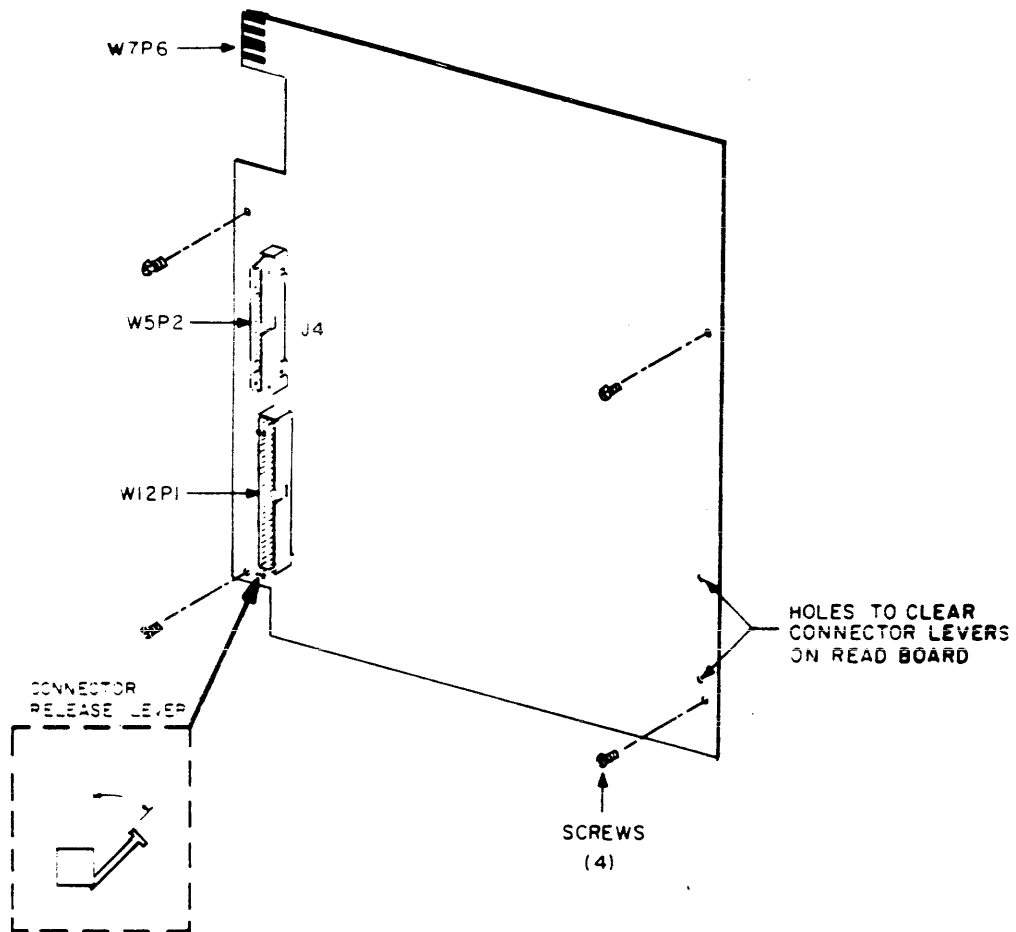

Figure 5-27. WRITE DRIVER MODULE CONNECTORS

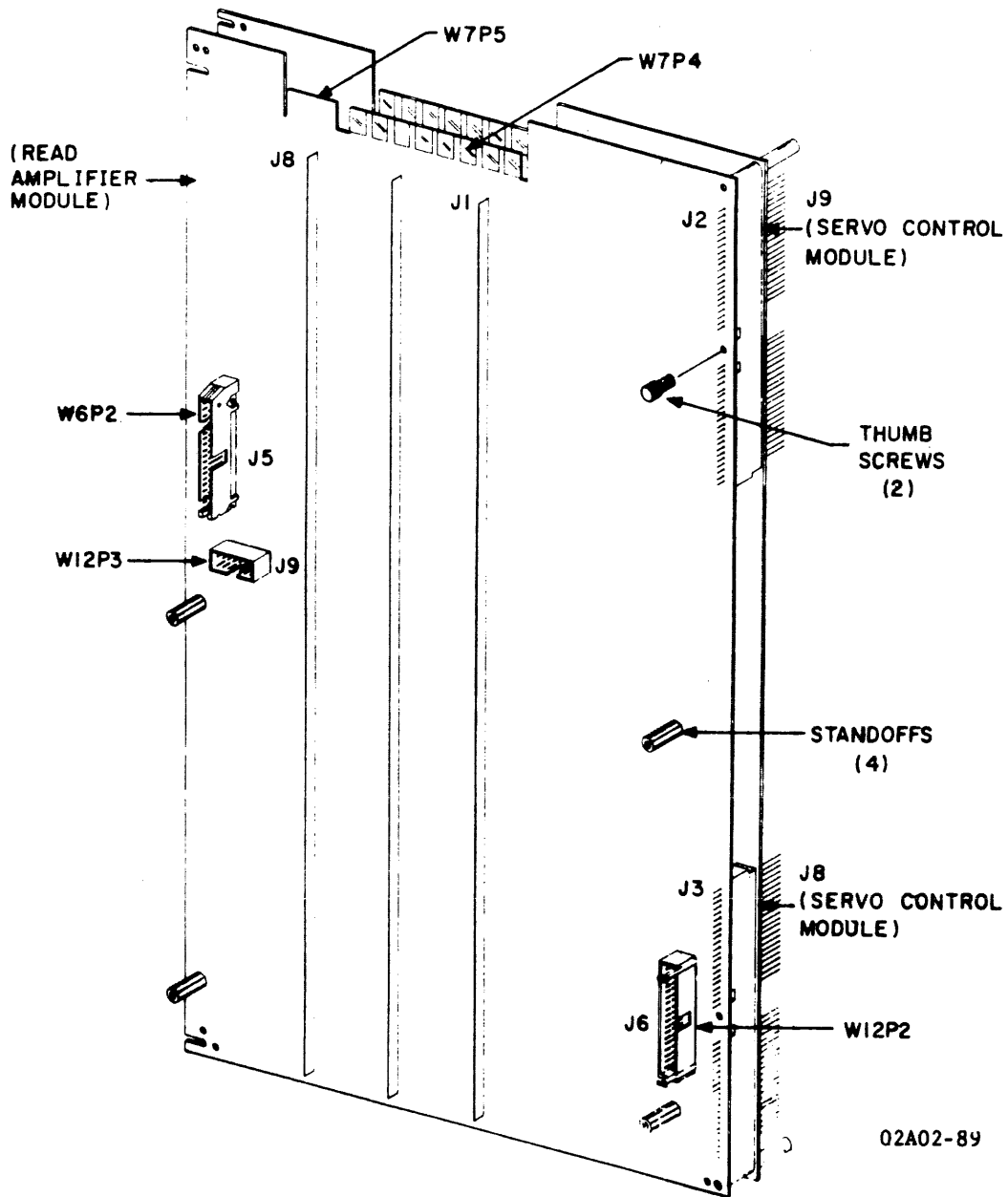

Figure 5-28. READ AMPLIFIER MODULE CONNECTORS

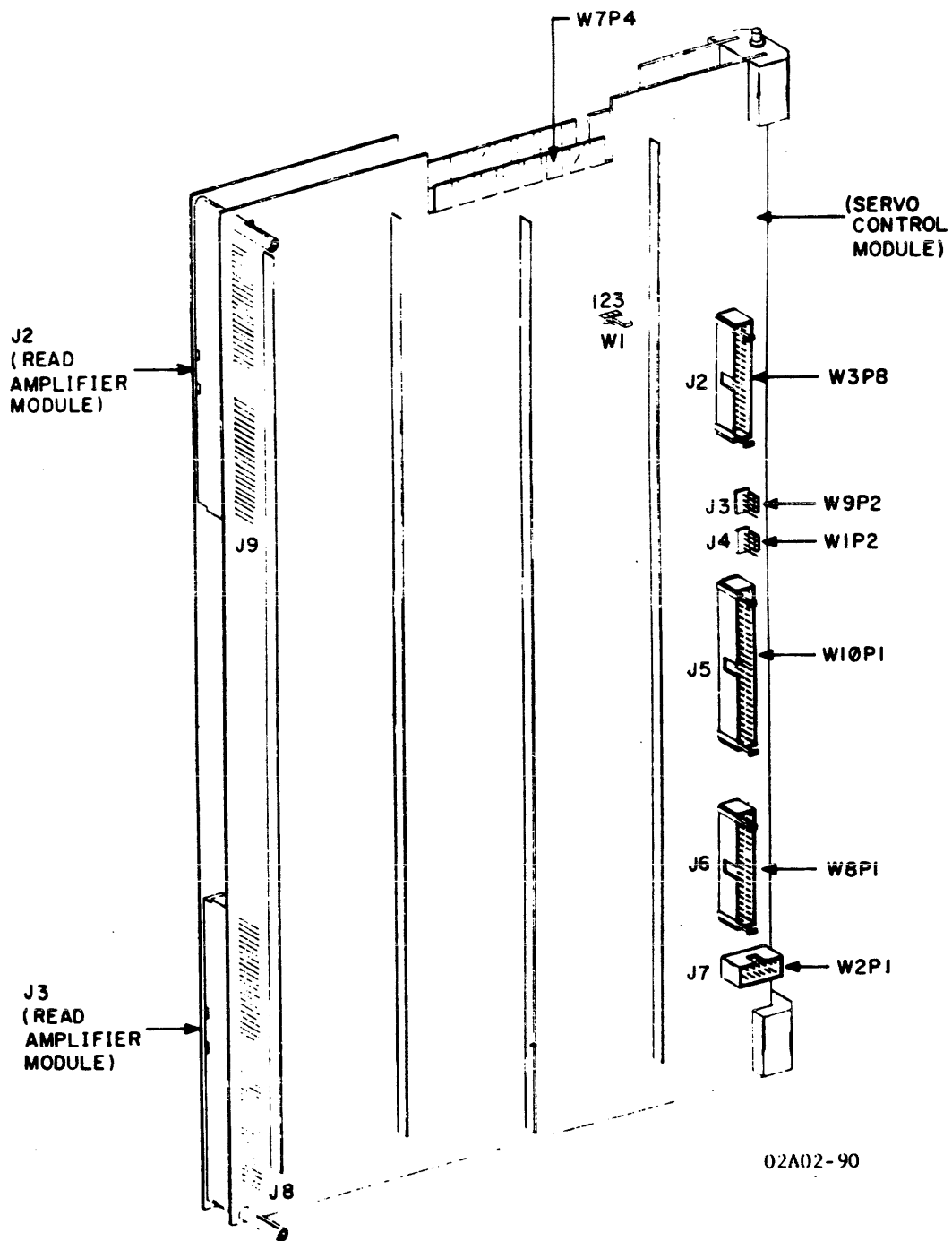

Figure 5-29. SERVO/CONTROL MODULE CONNECTORS

Write Driver Verification Check

1. Load a 377, or equivalent, write-enabled tape.
2. Execute Field Service Test 64.
3. Execute Field Service Test 31.
4. With tape threaded, but not loaded, execute operator test 01. If test is successful, it ends with display 00. If test is unsuccessful, perform Troubleshooting Procedures 1001 through 1003 as explained in the TU81/TA81 Pathfinder.

Read Amplifier Verification Check

1. Load a 377, or equivalent, write-enabled tape.
2. Move jumper W1 at location D23 on the servo control module to the 1-2 position (Figure 5-29).
3. Execute Field Service Test 31. If test is successful, it ends with display 00. If test is unsuccessful, compare the display number to the test description for test 31 in the TU81/TA81 Pathfinder.
4. After the test is successfully completed (display 00), return jumper W1 from the 1-2 position to the 2-3 position before powering down.
5. With tape threaded, but not loaded, execute operator test 01. If test is successful, it ends with display 00. If test is unsuccessful, perform Troubleshooting Procedures 1001 through 1003 as explained in the TU81/TA81 Pathfinder.

Servo Control Verification Check

1. Move jumper W1 at location D23 on the servo control module to the 1-2 position.
2. With tape not threaded, execute Field Service Test 37. If test is successful, it ends with display 00. If test is unsuccessful, compare the display number to the test description for Field Service Test 37 in the TU81/TA81 Pathfinder.
3. Execute Field Service Test 49.

Servo Control Verification Check (Cont'd)

4. Execute Field Service Test 64.
5. Execute Field Service Test 31. If test is successful, it will terminate with the display 00. If test is unsuccessful, refer the display number to the test description for Field Service Test 31 in the TU81/TA81 Pathfinder.
6. After the test is successfully completed (display 00), return jumper W1 from the 1-2 position to the 2-3 position before powering down.
7. Install and tighten the top and bottom thumbscrews to secure the modules to the logic cage.
8. With tape threaded, but not loaded, execute operator test 01. If test is successful, it will terminate with the display 00. If test is unsuccessful, perform Troubleshooting Procedures 1001 through 1003 as explained in the TU81/TA81 Pathfinder.

5.3.20 Formatter Read Module

Removal

1. Place the tape deck in the maintenance position (paragraph 5.2). Loosen the cage lock screws and slide the cage out until the top and bottom detents engage. See Figure 5-30.
2. Loosen the two thumb screws and separate the Formatter Read module from the Formatter Write module.

CAUTION

Avoid undue stress on the modules by loosening the thumb screws alternately and separating the modules as the screws are loosened.

3. Loosen and back out six to eight turns the upper screws of each hinge. Loosen the lower screws two turns (DO NOT remove). Hold the module in place while loosening the screws.
4. Remove the Formatter Read module from the logic cage.

Replacement

1. Insert the module into the top and bottom hinge slots of the cage. Make sure the module is fully inserted into the hinge slot and rear connector W7P8.
2. Attach the outside pin connectors of both modules and secure with the two thumb screws.
3. Tighten the upper and lower screws of the top and bottom hinges to lock the module into position. Make sure all four hinge screws are snug.
4. Release the upper and lower detents and slide the cage into the frame. Tighten the cage lock screw. Return the tape deck to the operating position.

Verification Check

1. Thread tape. Do not load. Execute Operator Test 01. If the test is successful, the test ends with display 00. If the test is unsuccessful, perform Troubleshooting Procedures 1001 through 1003 as explained in the TU81/TA81 Pathfinder.

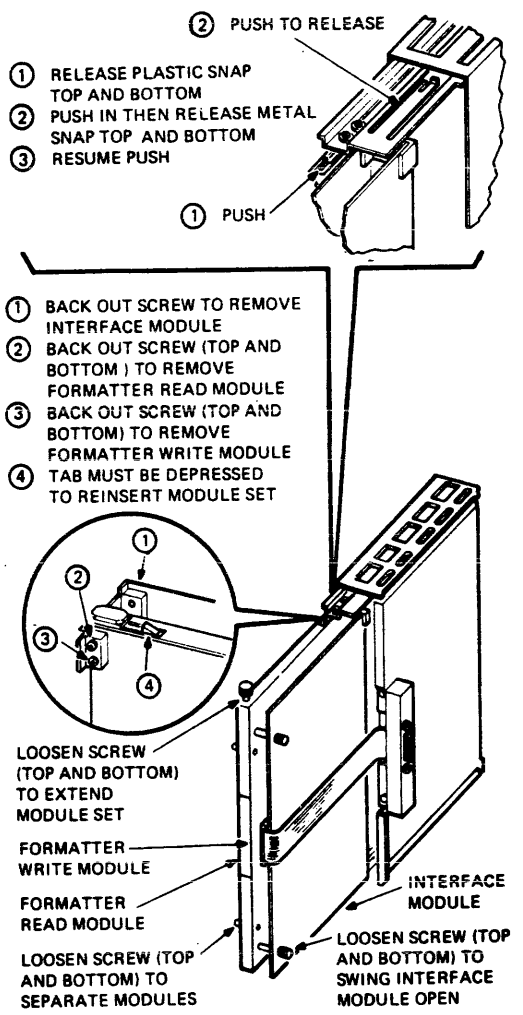

MA-0495-84
 SHR-0446-85

TU81

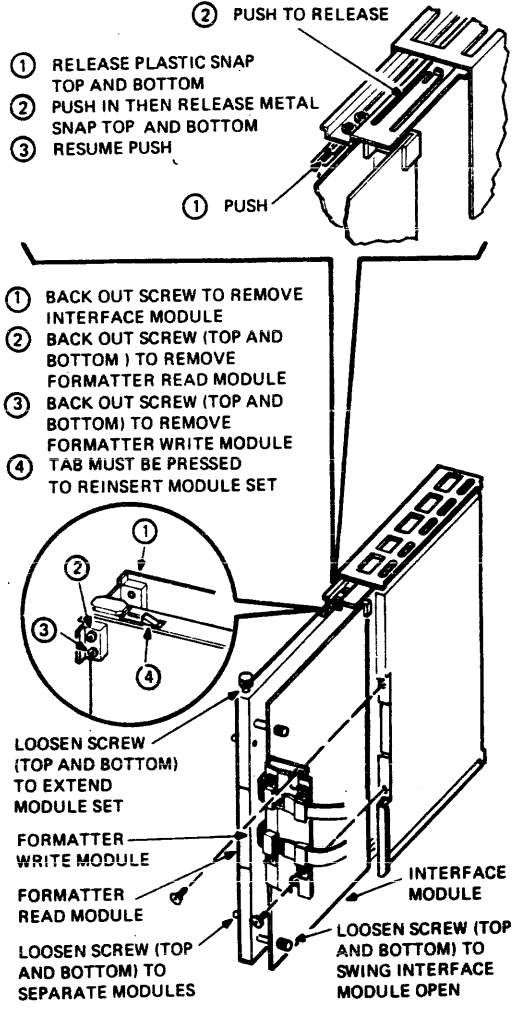

MA-0495-84
 SHR-0316-85

TA81

Figure 5-30. FORMATTER READ/FORMATTER WRITE/INTERFACE CONTROLLER MODULES

Figure 5-30A. FORMATTER READ/FORMATTER WRITE/INTERFACE CONTROLLER MODULES

Figure 5-30B. FORMATTER READ/FORMATTER WRITE/INTERFACE CONTROLLER MODULES

5.3.21 Formatter Write Module

Removal

1. Place the tape deck in the maintenance position (paragraph 5.2). Loosen the cage lock screw and slide the cage out until the top and bottom detents engage. See Figure 5-30.
2. Unscrew the top and bottom thumb screws securing the Interface Controller module to the Formatter Write module.
3. Remove connectors W10P2 and W11P from the module (Figure 5-31) and power supply connector W7P8 at the rear of the module (Figure 5-31).
4. Loosen the two thumb screws and separate the Formatter Read module from the Formatter Write module.

CAUTION

Avoid undue stress on the modules by loosening the thumb screws alternately and separating the modules as the screws are loosened.

5. Loosen and back out six to eight turns the lower screws of each hinge. Hold the module in place while loosening the screws.
6. Remove the Formatter Write Module from the cage.

Replacement

NOTE

Before installing the new module, make sure that the jumper blocks (W1, W2, and W3) at module locations A1 and B1 are in the same position as on the replaced module. See Figure 5-31.

1. Insert the module into the top and bottom hinge slots of the cage. Make sure the module is fully inserted into the hinge slot.

5.3.21 Formatter Write Module

Replacement (Cont'd)

2. Attach the edge pin connectors of both modules and secure with the two thumb screws.
3. Tighten the lower screw of the top and the bottom hinges to lock the module into position. Make sure all four hinge screws are snug.
4. Attach connectors W10P2 to J5, W11P1 to J4, and power supply connector W7P8 to the module.
5. Secure the Formatter Write module to the Formatter Read module and the Interface Controller module to the Formatter Write module using thumb screws as shown in Figure 5-30.
6. Release the upper and the lower detents and slide the modules into the cage. Secure them with the logic cage lockscrews. Return the tape deck to the operating position.

Verification Check

1. Thread tape. Do not load. Execute Operator Test #01. If the test is successful, the test terminates with display 00. If the test is unsuccessful, perform Troubleshooting Procedures 1001 thru 1003 as explained in the TU81/TA81 Pathfinder.

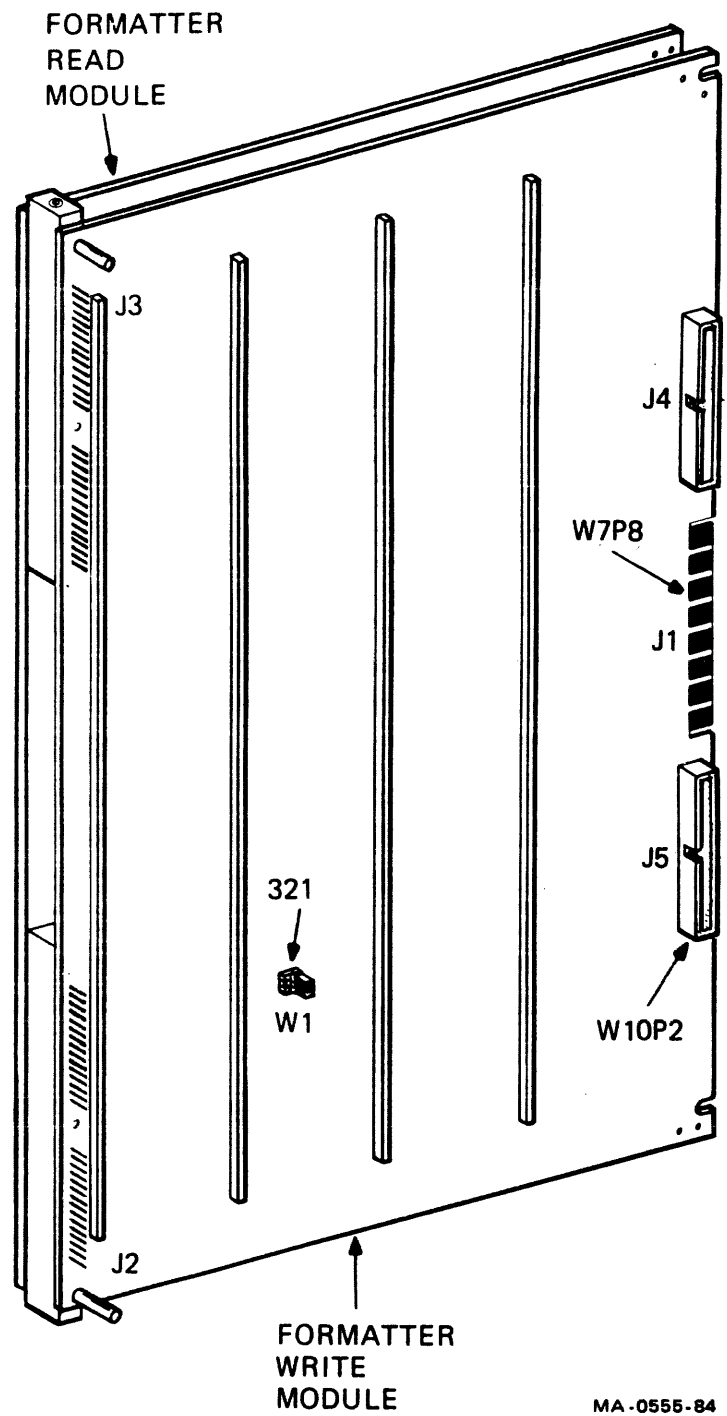

MA-0555-84

Figure 5-31. FORMATTER WRITE MODULE

5.3.22 Interface Controller Module

NOTE

The Interface Controller module may be the TMSCP module (in TU81) or the STI module (in TA81).

Removal

1. Place the tape deck in the maintenance position (paragraph 5.2). Loosen the cage lock screw and slide the cage out until the upper and lower detents engage. See Figure 5-30.
2. Unscrew the upper and lower thumb screws securing the Interface Controller module to the Formatter Write module.
3. When removing a TMSCP Interface Controller module, remove connectors W17P1, W15P1, W11P, and W18 (I/O cable). Refer to Figure 5-32A.

When removing an STI Interface Controller module, remove connectors W17P1, W15P1, W11P, and port A and B (STI) cables. Refer to Figure 5-32B.

4. Unscrew the top and bottom screws from the brackets shown in Figure 5-30 and remove the module from rear connector W7P9.

NOTE

Before installing a new Interface Controller module, make sure that the baud rate jumpers on the new module are in the same position as those in the replaced module.

Replacement

1. Insert the new module in the upper and lower brackets and secure with the upper and lower screws.
2. Install the cable connectors as follows (Figure 5-32):

W7P9 to J1
W11P to A1
W17P1 to J4
W15P1 to J5
W18 to J2 (TMSCP module)
Port A and B (STI) cables (STI module)

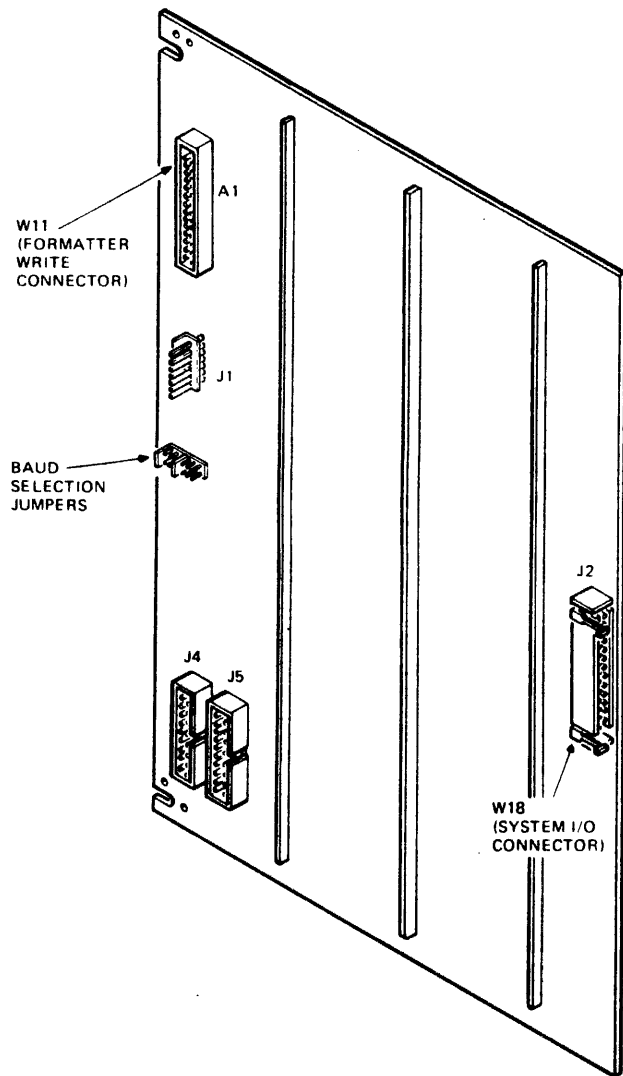

MA 0358 84

Figure 5-32A. TMSCP INTERFACE CONTROLLER MODULE

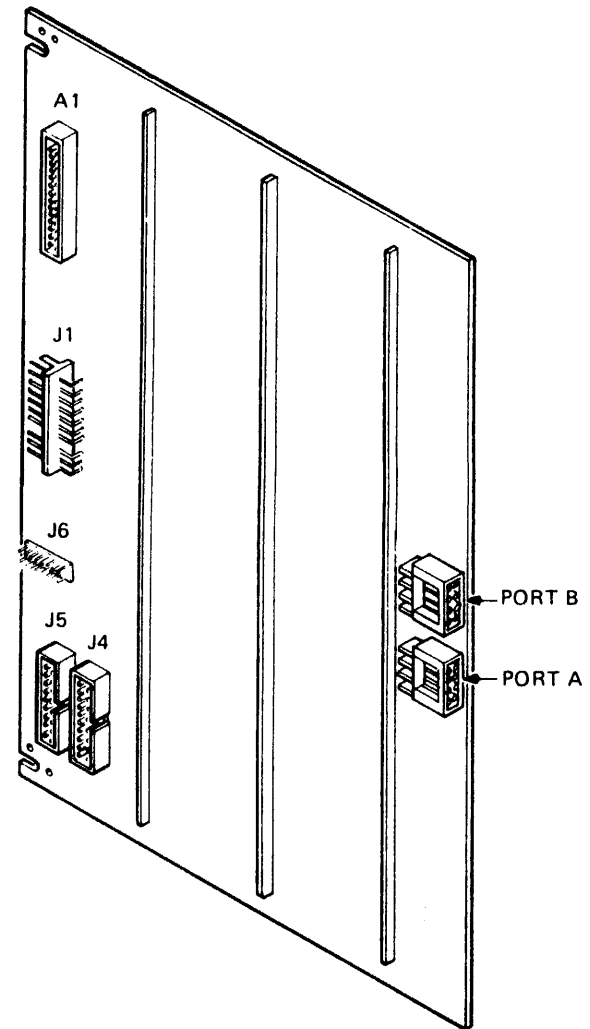

MA 0358 84
SHR-0317-85

Figure 5-32B. STI INTERFACE CONTROLLER MODULE

5.3.22 Interface Controller Module

Replacement Cont'd)

3. Tighten the upper and the lower thumb screws to secure the Interface Controller module to the Formatter Write module.
4. Release the upper and the lower detents and slide the cage into the frame. Tighten the cage lock screw. Place the tape deck in the operating position.

Verification Check

1. Applying DC power to the drive results in the execution of the Interface Health Check. If the check is successful, the unit identifier is displayed on the control panel display. If the test is unsuccessful, perform Troubleshooting Procedures 1001 thru 1003 as explained in the TU81/TA81 Pathfinder.

5.3.23 Power Amplifier Module

Removal

1. Place the tape deck in the maintenance position (paragraph 5.2).
2. Remove the drive cover (paragraph 5.3.1).
3. Remove the following connectors from the Power Amplifier module. (See Figure 5-33.)

B3P1 from J1

W3P7 from J2

B1P1 from J3

W7P7 from J4

C1P1 from J5

4. Release the three "Quick Disconnect" tabs along the outside edge of the module from the mounting assembly.
5. Remove the module.

Replacement

1. Insert the new module into the mounting assembly. The inside of the mounting assembly has metal slots to receive the module.
2. Secure the module by pressing it onto the tabs.
3. Install the connectors as follows.

B3P1 to J1

W3P7 to J2

B1P1 to J3

W7P2 to J4

C1P1 to J5

4. Install the drive cover.
5. Place the tape deck in the operating position.

Verification Check

1. Thread tape. Do not load. Execute Operator Test 01. If the test is successful, the test ends with display 00. If the test is unsuccessful, perform Troubleshooting Procedures 1001 through 1003 as explained in the TU81/TA81 Pathfinder.

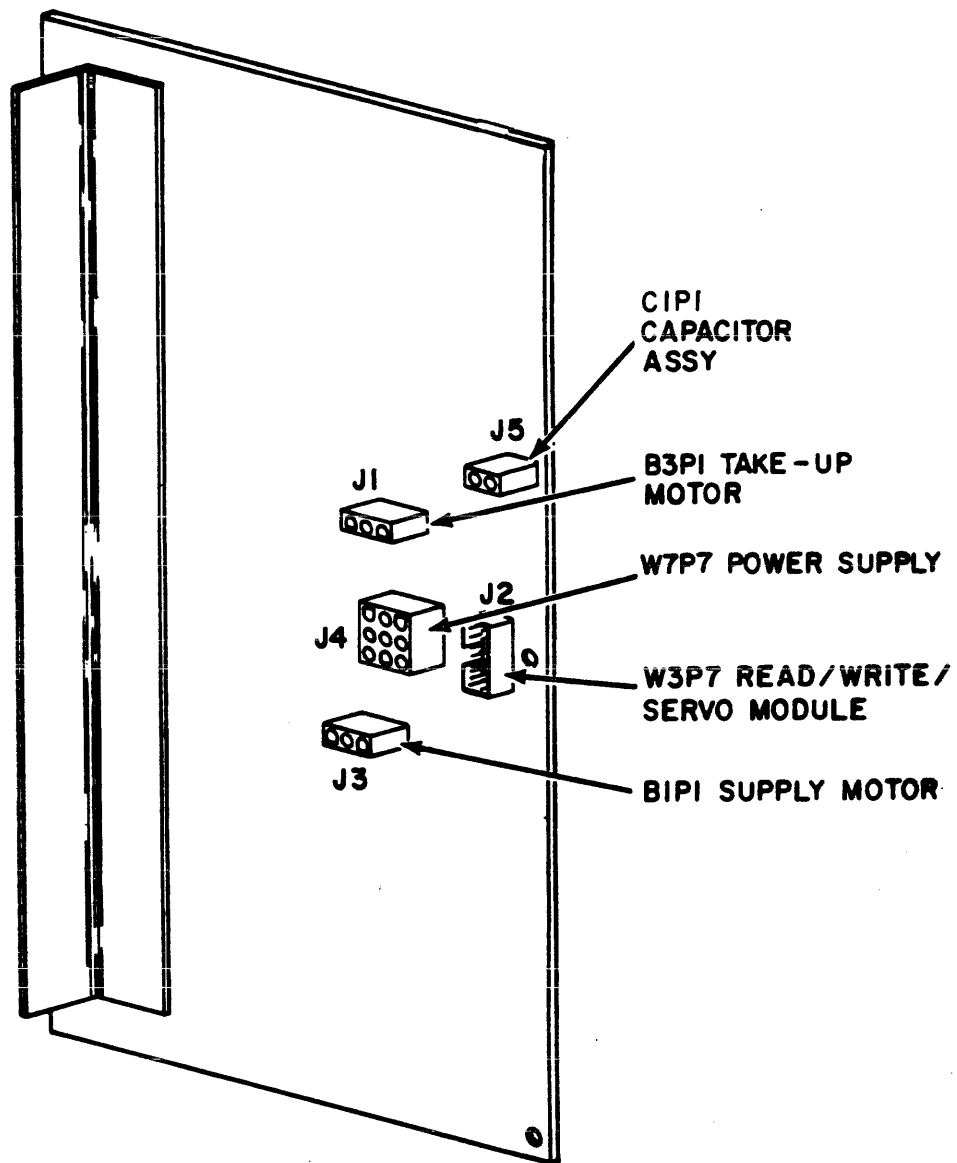

02A01-92

Figure 5-33. POWER AMPLIFIER MODULE

5.3.24 Capacitor Assembly

Removal

1. Place the tape deck in the maintenance position (paragraph 5.2) and remove the drive cover (paragraph 5.3.1).
2. Remove the capacitor connector from J5 of the Power Amplifier module. See Figure 5-34.
3. Insert a screwdriver through the access hole (see Figure 5-34) and loosen the screw holding the capacitor in the retainer. Remove the capacitor from the retainer.

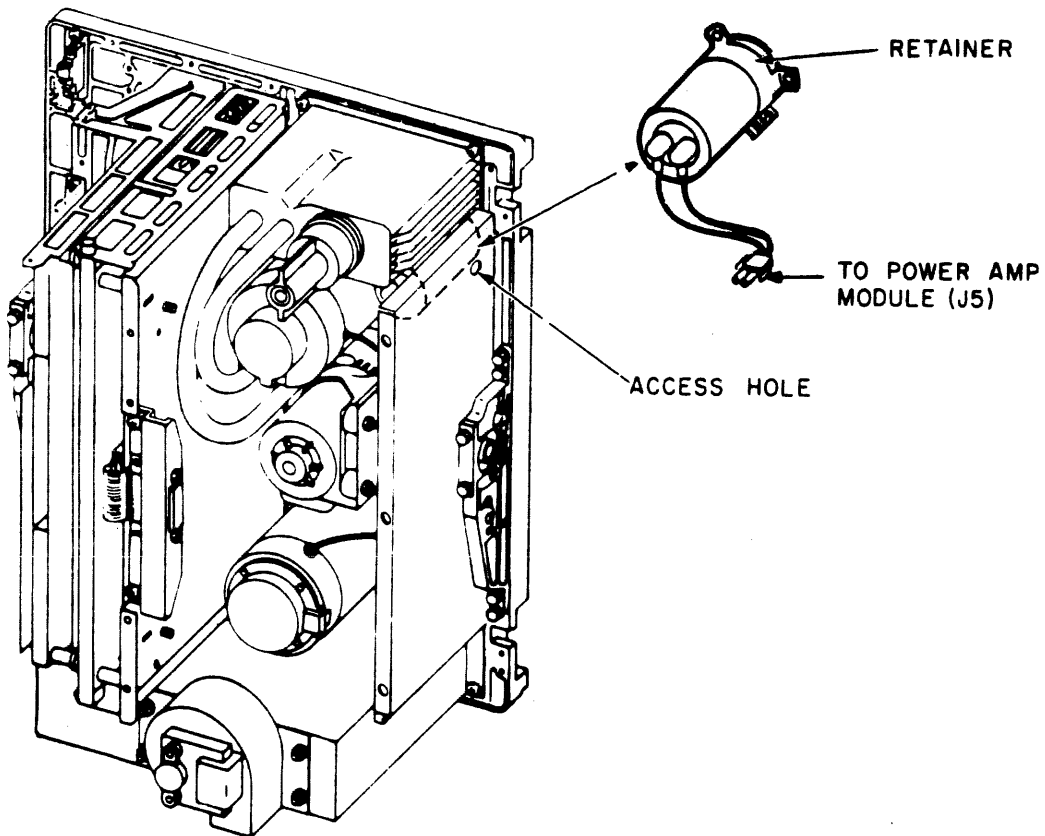

Figure 5-34. CAPACITOR ASSEMBLY

5.3.24 Capacitor Assembly

Removal (Cont'd)

NOTE

The capacitor loses its charge within four seconds after transport power is removed.

4. Slide the protective caps up from the capacitor terminals. Note the position of the connector wires in relation to the + mark on the capacitor. Remove the connector wires.

Replacement

1. Install the connector wires to the same capacitor terminal location as the original. Slide the protective caps over the terminals.
2. Place the capacitor in the retainer. Insert a screwdriver through the access hole and tighten the retainer screw until the capacitor is secured.
3. Install the capacitor connector in J3 of the Power Amplifier module.
4. Replace the drive cover. Place the tape deck in the operating position.

Verification Check

1. Thread tape. Do not load. Execute Operator Diagnostic Test 01.

5.4 TU81/TA81 DIAGNOSTICS AND TROUBLESHOOTING

5.4.1 General

Note To Field Service Representative:

When reporting to the site, obtain as much information from the operator and operating system, as available. Fault Codes, the frequency at which they occur and, if possible, the operation in progress at that time, are all things which should be considered prior to execution of the diagnostics. If the fault is intermittent, the information received from the operator and operating system may be instrumental in directing you to the appropriate test to duplicate the fault condition.

When troubleshooting the transport, follow the steps in the troubleshooting chart (Figure 5-35).

Complete information on troubleshooting, diagnostic procedures, and diagnostic test descriptions is given in the TU81/TA81 Pathfinder Manual (EK-OTU81/TA81-SV) provided in the CD Kit.

5.4.2 Resident Diagnostics

TU81/TA81 Resident Diagnostics consists of the Operator Diagnostics and Field Service Diagnostics.

NOTE

Make sure that the TU81/TA81 power cord is plugged in and the transport is energized (the power switch is ON) before starting any diagnostic routine.

The diagnostic tests designed into the TU81/TA81 are functions which can be initiated through the operator control panel or on-line by the host. The host controller is capable of monitoring TU81/TA81 status through the STATUS TRANSFER command. A CHANNEL LOOPBACK command is also provided to exercise the formatter logic of the TU81/TA81.

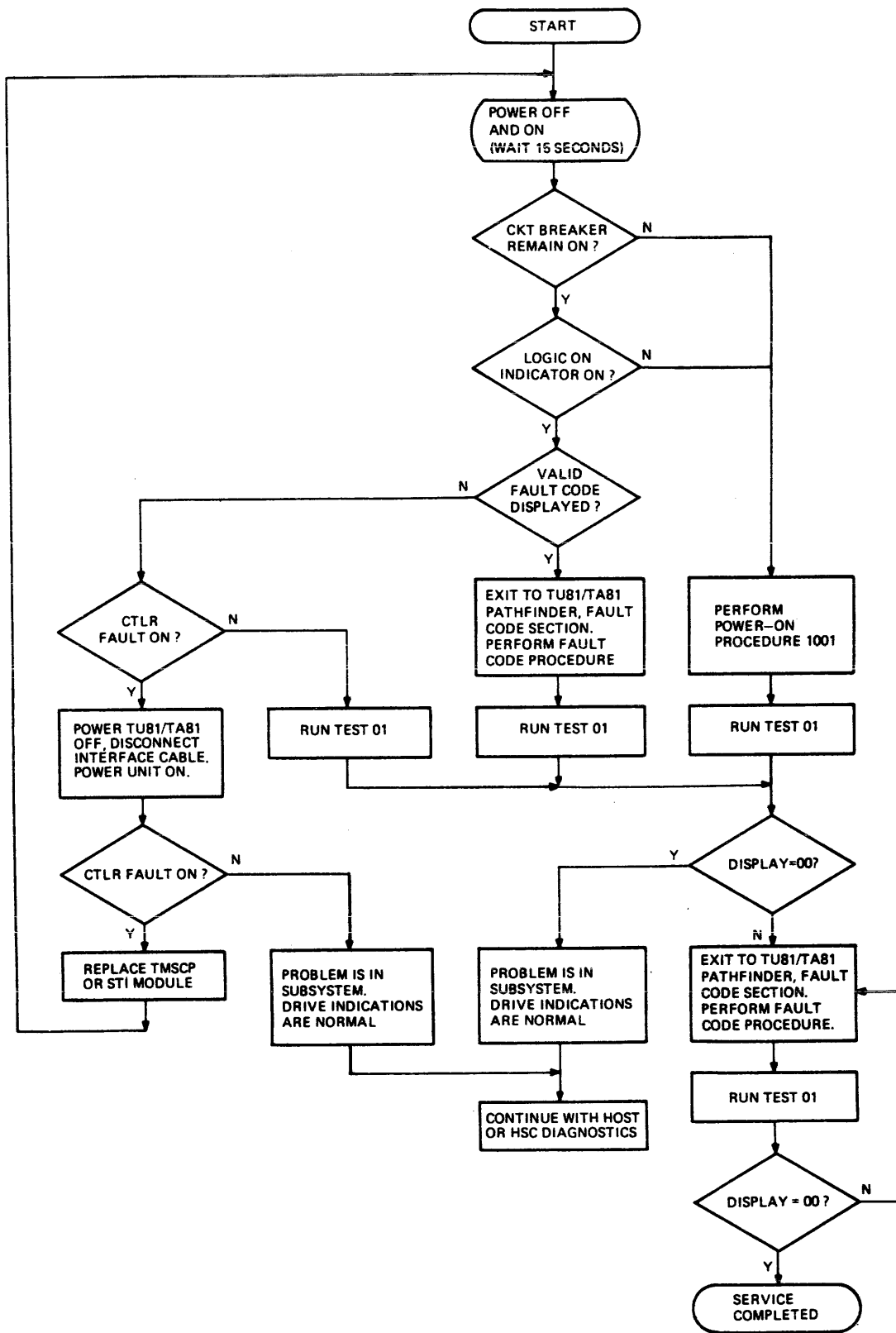

MA-0426-84
SHR-0448-85

Figure 5-35. TROUBLESHOOTING CHART

Even when not running diagnostics, the control microprocessor tests for many operational fault conditions while operating on-line. These conditions are indicated by fault codes which appear on the control panel display. The fault condition is indicated by illumination of the RESET indicator and the appropriate fault code being displayed. To prevent tape damage, faults which occur while tape is loaded may initiate a controller removal by the microprocessor of servo and write circuitry power.

The CONT/FAULT indicator comes on when the TMSCP (or STI) controller fails. It also can indicate that there is a problem with the M8739 module (for TU81).

5.4.2.1 Corrective Fault Code Matrix - When the fault condition is recorded, consult the Fault Code Matrix (Table 5-2) and corresponding corrective action tables in the TU81/TA81 Pathfinder to determine if an operator action (A, B, or C) is required. If the fault still persists after an appropriate action, consult the tables for the list of Field Replaceable Units that may be required to be replaced.

The Fault Code Matrix lists malfunctions or fault codes and possible assemblies which may cause the fault condition. Test 01 is a lead-in to all other tests. The purpose of this table is to provide a list of related assemblies prior to reporting to the customer site. Assemblies listed under the individual malfunction or fault codes are arranged in a "most probable fault" order. In addition to the assemblies listed, the table may direct the service personnel to request the operator to perform Diagnostic Test #02 or #03.

When on-site, consult and use the TU81/TA81 Pathfinder (Troubleshooting Procedures and Diagnostic Tests) to isolate and correct the malfunction.

5.4.2.2 Preliminary Troubleshooting - Before running any tests, check the following to isolate an easily correctable external malfunction:

1. Make sure that the tape has a BOT marker.
2. If a write operation is to be performed, make sure that the tape reel has the write enable ring installed.
3. Verify that the tape path is clean.
4. Verify that the power switch is ON (1).
5. In case of power failure, verify that the power controller circuit breaker is ON.
6. Make sure that the top cover door is closed and latched.

NOTE

If the host computer reports data (read/write) errors, "first-aid" action is to clean the tape path.

Table 5-2. FAULT CODE MATRIX (Cont'd)

ASSEMBLY/ACTION	FAULT CODE																												
	30	31	32	33	34	35	36	41	42	43	47	48	50	51	52	53	54	55	56	60	61	62	63	64	65	66	67	68	69
Test Successful																													
Clean Hub Pads																													
Thread Tape Correctly																													
Clean Head/Tape Path/Hubs	A	A										A																	
Change Tape												B																	
*Close Top Cover																													
Run Test 02 (See NOTE 1)	X	X					X																						
Run Test 03 (See NOTE 1)	X	X	X	X		X						X			X														
(See NOTE 2 Below)																													
Servo-Control	1	1	2	1	1	1	1	1	3	3	1		1	1	2	1	3	1	2										1
PE/GCR Read Amplifier							10										2												
PE/GCR Write Driver							9									1													
Formatter Read							12																	1	1	1			
Formatter Write							13																	1	2	2		2	2
Interface																													
Power Supply																													
Power Amplifier	2	2	1				2																						
Control Panel																													
Pneumatic Pump	4	4	4				4																						
Filter	5	5	5				5																						
**Supply Air Bearing	7	7					7																						
Take-Up Air Bearing	8	8					8																						
Head (Amplitude Error)																													
Head (Data Reliability)							11										4												
Supply Motor/Tach													2			3													
Supply Hub																													
**Take-Up Air Bearing	3	3	3	2			2	3				3				1													
EOT/BOT Sensor																													
Top Cover Switch																													
File Protect Sensor																													
Pressure Regulator	6	6	6				6																						
Cooling Fan												1	1																
Temperature Sensor												2	2																

* OPERATOR CORRECTIVE ACTIONS

** FAILING ASSEMBLY

NOTE 1. Do not run Tests 02 and 03 unless Test 01 directs their use. Test 02 will not run Stand-alone.

NOTE 2. A Fault can be caused by the operator pressing any operator panel switches for longer than 15 seconds during the power-up cycle.

5.4.2.3 Diagnostic Mode Operating Instructions - To get into the diagnostic mode and initiate the Operator or Field Service ("CE Tests") Diagnostic Tests, use the diagnostic panel as follows:

1. To initiate Operator Diagnostic Test 01, press the TEST switch. 01 will be displayed. Press EXECUTE to initiate the test.
2. To initiate the Field Service Diagnostics Tests, press and hold the CE switch, then press the TEST switch.
 - a. The DIAGNOSTICS indicator lights.
 - b. The display shows 00.

Press the STEP switch.

- a. Display number increments by one each time the STEP switch is pressed, or will increment automatically if the STEP switch is held pressed. The display can show 00 thru 09.
- b. To select the required test number, use the STEP and TEST switches. When you press the TEST switch after the STEP switch, the number is multiplied by ten.

Example: Test 39 is required.

- | | |
|---|-------------|
| o Press the CE and Test switches. | Display: 00 |
| o Press the STEP switch three times. | Display: 03 |
| o Press the TEST switch. | Display: 30 |
| o Press the STEP switch until 9 is displayed. | Display: 39 |

Press the EXECUTE switch to start the test.

After the fault code appears on the display, you can view the sub-fault code by pressing the CE switch. The sub-fault code will be displayed as long as the CE switch is held pressed.

5.4.2.4 Resident Test Descriptions - Resident Diagnostics include the Power-on Health Check, Operator Test 01, Unit Number Procedure (Test 04), and Field Service Tests as shown on the Troubleshooting Chart (Figure 5-35). The Field Service Diagnostics are described and listed in the TU81/TA81 Pathfinder Manual.

5.4.2.4.1 Power-on Health Check - This is automatically performed by the transport when the POWER switch (circuit breaker) in the far right corner of the tape deck is set in the ON position (1 pressed).

This built-in diagnostic (Figure 5-36) checks dc power distribution (i.e., availability of all required dc voltages on the electronic modules' inputs) and normal operation of the control panel indicators.

If the check is successful, all indicators momentarily go on and off. Then the LOGIC ON and FILE PRO indicators come on indicating the normal stand-by operating condition. The three-digit display will show the Unit Number.

NOTE

LOGIC ON and LOGIC OFF indicators are used as dc power lights. LOGIC ON shows normal power status, LOGIC OFF indicates power failure.

If a power failure is detected at power-up, a fault code may appear on the display, the LOGIC OFF and FAULT indicators should light up, and the LOGIC ON should go off.

NOTES

If a fault code appears on the display, press RESET to clear the display. Then press the POWER switch again to repeat the Health Check.

If the fault code reappears, refer to the TU81/TA81 Pathfinder for on-site troubleshooting procedures and Field Service Diagnostic Tests to isolate the failure.

5.4.2.4.2 Operator Diagnostic (Test 01) - The operator diagnostic consists of one selectable test (Test 01) which runs for approximately 10 minutes, when a 2400 foot tape is used. Faults encountered during the test terminate the diagnostics and display a numerical code on the display panel. Any fault code should be logged by the operator and reported to the field service representative, if operator corrective actions do not resolve the problem. The operator diagnostics are initiated as follows:

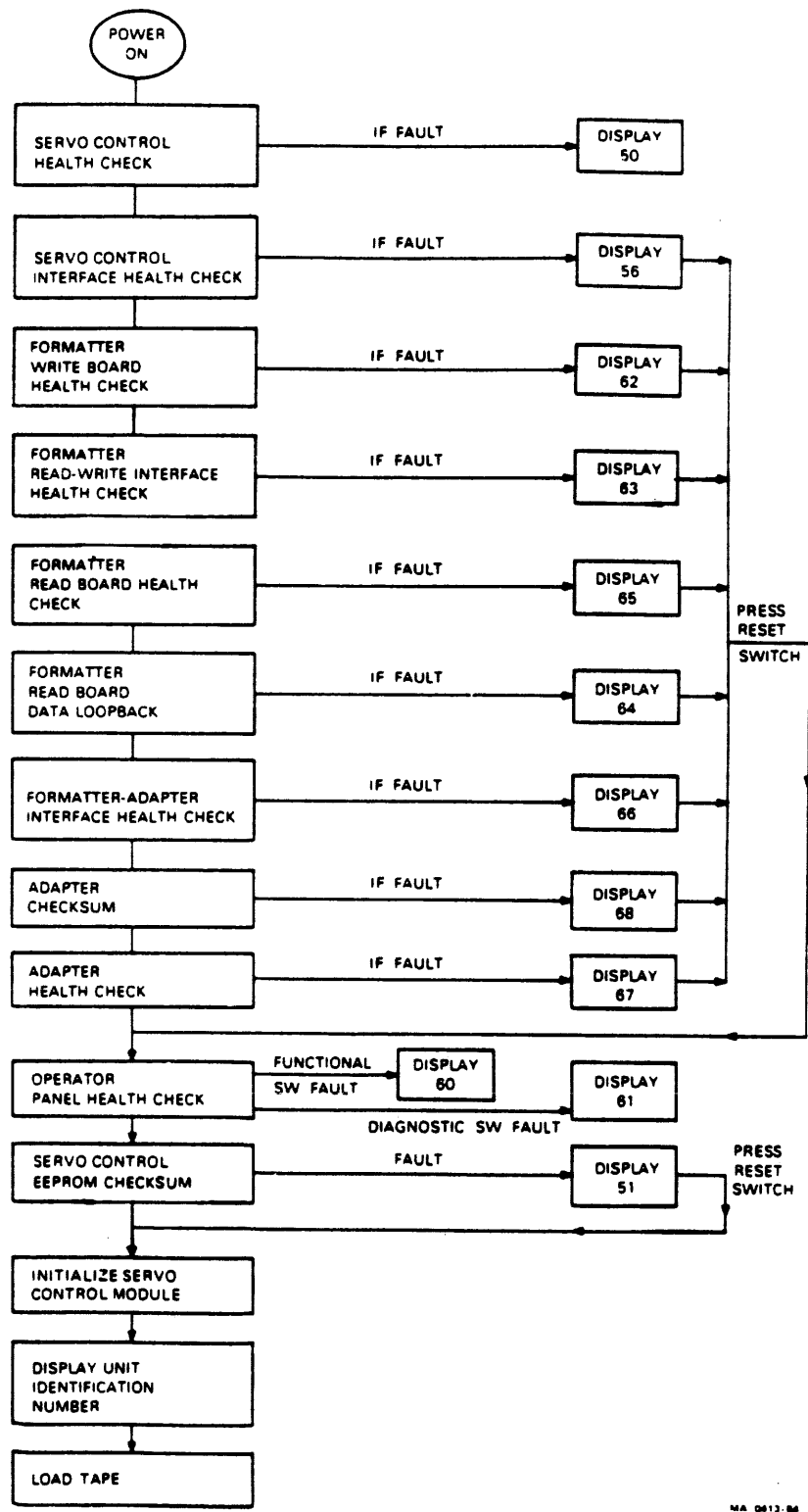

MA 0613-84

Figure 5-36. POWER-ON HEALTH CHECK FLOWCHART

o Transport Status

1. Transport powered on (LOGIC ON indicator lit).
2. Tape threaded through tape path and onto take-up reel, but not loaded (untensioned).

o Test Procedure

1. Press TEST switch.
 - a. DIAGNOSTIC indicator lights.
 - b. Display panel shows 01.
2. Press EXECUTE switch.
 - a. Test starts with display panel incrementing from 000 thru 999. Verify that all segments of the numerical display are functioning.
 - b. Concurrent with step a. above, the following indicators are lit: FILE PRO, LOGIC ON, ON-LINE, RESET/FAULT, and DIAGNOSTICS.
 - c. Test continues with various motion and read/write exercises for approximately 10 minutes.

The transport performs a Rewind/Unload operation and 00 appears on the display panel if the test runs to completion. If the test is unsuccessful, the test terminates and a fault code appears on the display panel. If the problem cannot be resolved through operator actions, as indicated in Table 5-2, the fault code is referenced directly to the corresponding troubleshooting procedure for corrective action.

When referring to the Fault Code Troubleshooting Procedures for corrective action, a Sub-Fault Code interrogation may be required. With the fault code still indicated on the display panel, press and hold the CE switch. This action will cause the Sub-Fault Code to appear on the display.

5.4.2.4.3 Unit Identification - The Unit Identification Number is a unit address feature giving each tape transport a unique ID code (from 0 to 255) to be recognized by the host. This ID is especially useful in a multi-drive configuration since it gives you the opportunity to re-address peripheral device from one tape drive to another in case of emergency (tape drive failure, connection breakdown, etc.).

The Unit Number is a three-digit code that is manually entered from the transport control panel using the procedure (Test 04) shown below. This code is stored in the transport non-volatile memory (which retains stored data in case of power fluctuations or failure) until you enter a new unit ID number. The Unit Number is constantly indicated on the display panel when the drive is powered on and is in the normal on-line, off-line, or tape-unloaded status. When there is a fault condition, or a diagnostic test is running, the Unit Number is replaced by the fault code or test number indications.

Example - To enter Unit Identification Number 201, use Test 04 and proceed as follows:

* Press simultaneously CE and TEST switches	-- DIAGNOSTIC indicator lights -- display = 00
* Press STEP four times	-- display = 04
* Press EXECUTE	-- display = 000
* Press STEP twice	-- display = 002
* Press TEST twice	-- display = 200
* Press STEP once	-- display = 201

To store that ID code in the transport memory,

* Press EXECUTE	-- display = 00
* Press RESET to return the drive to operating condition	-- display = 201

5.4.2.4.4 Tape Sticking Problem - If you have a possible tape sticking problem, run Test 82. For the test description, refer to the TU81/TA81 Pathfinder. If this test ends with the unit number flashing on the display, replace the tape.

5.4.3 Field Service Diagnostic Listing

The TU81/TA81 Pathfinder lists all the built-in Field Service troubleshooting procedures and tests provided by the TU81/TA81 tape subsystem. Refer to this document after you perform test 01. If there is a failure that cannot be detected by test 01, perform troubleshooting procedures 1001 through 1003 to manually check out the transport.

5.5 TU81 VAX-EXECUTABLE DIAGNOSTICS

This section lists and describes all VAX-executable diagnostics that can be used to check out and accept a TU81 subsystem when it is installed on a VAX system. The VAX-executable diagnostics are as follows.

1. VAX front-end diagnostics (EVMBB)
2. VAX data reliability diagnostic (EVMBBA)

NOTE

Refer to the documentation of the installed Digital computer for information on how to run and interpret the host diagnostics.

5.5.1 M8739 Status Checking

Before running the VAX diagnostics, check the TU81 and I/O connection status using the SHOW DEVICE command. Then the system checks the M8739 module in either of the following conditions.

5.5.1.1 TU81 Add-On Configuration -- At system power-up, the host automatically configures the tape unit into the system. If the M8739 fails any time after, the host is unable to access the TU81, and an error message is entered in the system error log.

5.5.1.2 On-Line Operation Failure -- If the M8739 fails during normal on-line operation, the host is unable to continue to access the TU81, and an error message is entered in the system error log. When the operator tries to recall the TU81, the appropriate message appears on the operator's terminal indicating the "abnormal" status of the corresponding device.

Use SHOW DEVICE PT to check the connection to the I/O controller and SHOW DEVICE MU to check out the TU81 transport connection.

5.5.2 VAX Front-End Diagnostic (EVMBB)

This diagnostic checks the subsystem in all basic modes of operation and tests the TU81 logic, interface bus, and I/O silo. It can only be performed with the host off-line.

The front-end diagnostic consists of three test sections: DEFAULT, MANUAL, and FAULT. For acceptance testing purposes, when the TU81 is checked at system initialization, transport add-on, or after repairs, only the DEFAULT and MANUAL sections are used. All three test sections are used for routine testing of the TU81 subsystem. Each section contains several tests that check various modules and functions of the TU81 subsystem.

5.5.2.1 DEFAULT Section - DEFAULT section tests do not require magnetic tape. This section is used to check the subsystem interface. The section contains the nine tests listed. It executes by either of these commands.

```
DS> RUN EVMBB
    or
DS> START
```

NOTE

DS> is the prompt from the diagnostic supervisor. Do not type DS>.

Tests

- 1 Register existence
- 2 Power-up initialization
- 3 Steps 1--3 initialization
- 4 Diagnostic SA wrap
- 5 Vector and BR level
- 6 Purge and poll
- 7 Small ring buffer initialization
- 8 Large ring buffer initialization
- 9 Get DUST status

To start an individual test in this section, enter

```
DS> START/TEST:n
```

where n is a test number from 1 to 9.

The diagnostic begins at the specified test and proceeds until the end of the section.

5.5.2.2 MANUAL Section - The MANUAL section test requires operator intervention to mount and remove the magnetic tape when requested by the diagnostic through the console terminal. This section runs the preselected transport microdiagnostic test 01, which is designated test 10 in this section.

To start the section, use this command.

```
DS> RUN EVMBB/SEC=MANUAL
```

5.5.2.3 FAULT Section - This section requires operator intervention to mount and remove the magnetic tape when requested by the diagnostics through the console terminal. This section runs preselected transport microdiagnostics consisting of three tests (tests 11 through 13).

To start the section, enter this command.

```
DS> RUN EVMBB/SEC=FAULT
```

The tests are as follows.

- 11 Tension fault isolation (drive resident test 02)
- 12 Velocity fault isolation (drive resident test 03)
- 13 Select a drive resident test (tests 01 to 99)

To select an individual test, enter

```
DS> RUN EVMBB/SEC=FAULT/TEST:n
```

where n is any number from 11 to 13.

To run test 13, use the following example.

```
DS> START/SEC=FAULT/TEST=13
```

```
Testing: MUA0
```

```
Test 13: Select a Drive Resident Test (1--99)
```

```
Enter the TU81 Drive Unit Number: 0
```

```
Enter the drive resident test number <1--99>: 91
```

```
READY? [(No), Yes] Y
```

5.5.3 VAX Data Reliability Diagnostic (EVMBBA)

This diagnostic provides a complete tape subsystem checkout. It allows you to test the TU81 operation on-line without bringing the system down. The EVMBBA consists of three test sections (a total of five tests) as follows.

DEFAULT Section

- Acceptance (test 1)
- Qualification (test 2)
- Multidrive (test 3)

MEDIA Section

- Read interchange (test 4)

CONVERSATION Section

- Conversation mode (test 5)

To initiate a complete EVMBA run, load EVMBA and enter either of these commands.

```
DS> RUN EVMBA
    or
DS> START
```

To run any of the sections, enter the section start command, for example:

```
DS> START/SEC=MEDIA
```

To run an individual test in the DEFAULT section, enter

```
DS> START/SEC = DEFAULT/TEST:n
```

where n is a number from 1 to 3.

5.5.4 Basic Operating Instructions for VAX-Based Diagnostics

Follow these instructions when running VAX diagnostics.

1. Load the diagnostic supervisor (ENSAA, ECSAA, or ESSAA) for the applicable computer system.

NOTE

```
Use ENSAA on the VAX-11/730.
Use ECSAA on the VAX-11/750.
Use ESSAA on the VAX-11/780.
```

2. Attach and select the devices to be loaded in one of two ways.

- a. Prompt mode
Attach the UNIBUS adapter to the appropriate bus.

```
DS> Load EVMBX
DS> Attach
Device Type? DWXXX
where XXX is 780, 750, or 730
Device Link? HUB DWO 3 4
```

Attach the tape transport

```
DS> Attach
Device Type? TU81
Device Link? DWO
Device Name? MUAO
CSR? 774500
Vector? 260
BR? 5
DS> Start/Switches
```

- b. Explicit mode
 - DS> Load EVMBX
 - DS> Attach DWXXX HUB DWO 3 4
 - DS> Attach TU81 DWO MUAO 774500 260 5
 - DS> Select MUAO
 - DS> Start/Switches

NOTES

1. In the above diagnostics, no hard errors are allowed.
2. For control flags, refer to the VAX diagnostic listings.
3. Load EVMBB by booting from a load media device; for example, type
 |||>B/10 DXXX||| (DXXX = BOOT device).

Example:

1. Initialize and log in on the VAX system.
2. Check the subsystem availability using the SHOW DEVICE command.

```
$ SHOW DEV PT    Checks I/O connection and status.
$ SHOW DEV MU    Checks TU81 transport status.
```

3. Perform the EVMBA diagnostic.
 - \$ R ESSAA
 - DIAGNOSTIC SUPERVISOR, ZZ-ESSAA-
 - DS> LOAD EVMBA
 - DS> ATTACH DW780 HUB DWO 3 4
 - DS> ATTACH TU81 DWO MUAO 774500 260 5
 - DS> SELECT MUAO
 - DS> START

4. Continue with the EVMBB diagnostic.

```
Load EVMBB by booting from a load media device.
>>> B/10 DUAO (DUAO = RA81)
```

```
DIAGNOSTIC SUPERVISOR, ZZ-ESSAA
DS> LOAD EVMBB
DS> ATTACH DW780 HUB DWO 3 4
DS> ATTACH TU81 DWO MUAO 774500 260 5
DS> SELECT MUAO
DS> START/Switches
```

5.5.5 System Exerciser

The system exerciser (UETP) for the TU81 is fully supported under VAX/VMS Version 3.6, but it is not supported in VAX/VMS Version 3.5. However, it is possible to run TU81 under VMS Version 3.5 if you modify the UETP data file slightly.

Edit the file [UETSUPDEV.DAT] to include the new line as follows.

```
02 03 UETTAPEOO.EXE !TU77
02 08 UETTAPEOO.EXE !TU81      ← Add this line.
02 05 UETTAPEOO.EXE !TU78
```

5.5.6 EVMBB Sample Error Printout

The following is an example of the error printout that is returned whenever the TU81 fails to execute a drive resident diagnostic while running under EVMBB.

```
***** EVMBB TU81 FRONT-END/HOST DIAGNOSTIC - 2.0 *****
PASS 1, TEST 13, SUBTEST 0, ERROR 18, 18-MAY-1984 10:53:27.13
HARD ERROR WHILE TESTING MUAO: INTERNAL DIAGNOSTIC FAILED
```

```
SA = 0000 (X)
FAULT CODE = 09
SUBFAULT CODE = 03
```

```
$ SHOW DEV PT
$ SHOW DEV MU
```

5.6 TU81 PDP-11-EXECUTABLE DIAGNOSTICS

This section lists and describes all PDP-11-executable diagnostics that can be used to check out and accept a TU81 subsystem installed on a PDP-11 system.

NOTE

Refer to the documentation of the installed Digital computer for information on how to run and interpret the host diagnostics.

5.6.1 Operating Instructions for PDP-11-Based Diagnostics
Follow this procedure when using PDP-11-based diagnostics.

1. Load XXDP+ monitor.
 - a. Enter date
2. Answer hard core questions.
 - a. 50 Hz? Y or N
 - b. LSI? Y or N

This is XXDP+. Type H or H/L for details (Help File).

[Receive XXDP+ prompt (dot)]

3. Enter R (space) program name.

The program may be CZTU2 or CZTU1.

The operator entry should look like this.

[.R ZTU2??]
4. Receive DR> prompt.
5. Enter the appropriate command.

For example,

DR>STA to start the test.
6. Change HW(L)? Y or N
7. Change SW(L)? Y or N

5.6.2 CZTU2 Front-end Functional Diagnostic

CZTU2 is the first host level diagnostic run, since it tests the basic functionality of the TU81 subsystem.

CZTU2 tests up to four TU81 subsystems. To run a full pass of the program, a scratch tape must be mounted on the transport and an operator must be present to perform manual intervention.

The first pass of the program is a "quick verify." For a single unit under test, the first pass takes about 20 minutes. All subsequent passes run multiple iterations of each test listed; these passes each take about 24 minutes for a single unit under test.

- Test 001: Existence Verification
- Test 002: Initialization
- Test 003: Initialization
- Test 004: SA Register Wrap
- Test 005: Vector and BR Level
- Test 006: Purge and Poll
- Test 007: Small Ring
- Test 008: Maximum Ring Buffer
- Test 009: Get DUST Status
- Test 010: Functional Fault Detection
(Internal Drive Test 1)
- Test 011: Tension Fault Isolation
(Internal Drive Test 2)
- Test 012: Velocity Fault Isolation
(Internal Drive Test 3)
- Test 013: Select A Drive Resident
(Internal Drive Tests 1-99)

5.6.3 CZTU1 Data Reliability Test

This diagnostic tests the performance quality of the TU81 subsystem.

CZTU1 tests up to four TU81 subsystems. A scratch tape must be mounted on the transport to run this test. Each pass takes about 1 hour and 10 minutes for each unit under test.

- Test 001: Basic Function
- Test 002: Quick Verify Read/Write
- Test 003: Complex Read/Write
- Test 004: Write Interchange Tape
- Test 005: Read Unknown Tape
- Test 006: Start/Stop Write/Read
- Test 007: Conversation

5.6.4 CXTUCA DEC/X11 Module

This module streams the drive in both read and write modes. Each pass begins where the previous pass left off. In effect the entire reel of tape is written and read.

CXTUCA tests a single TU81 subsystem.

5.7 MAINTENANCE INDICATORS AND FAULT/ERROR CODES

The four methods that a TU81 subsystem uses to display error and status conditions are, in order of decreasing severity:

1. Lighting the controller fail indicator,
2. Depositing a fatal error code in the I/O page SA register,
3. Displaying a fault code on the operator panel, and
4. Sending a TMSCP error log packet with error/status code to the host.

A TU81 subsystem uses these four methods in different combinations, depending on the type and severity of the particular error.

- o Fatal errors (detected by internal microdiagnostic routines or other checks in the master drive's controller) light the controller fail indicator and leave a fatal error code in the host system I/O page SA register.
- o TMSCP command errors return error codes and send corresponding error log packets to the host, if enabled.

Table 5-3 lists the assigned fatal error codes and the reason for the error. Error codes in the range of 100001 through 100026 (octal) are generic TMSCP controller codes; error codes in the range of 100454 through 100460 are specific to the TU81. These codes can be printed out while running host-level diagnostics, or they can be accessed by reading the SA register (default 774502(8) or F942(16)). All of these codes include bit 15 set so that any time the host finds bit 15 of the SA set, it knows that one of these errors has occurred. Host level diagnostics print out the code, including bit 15. Paragraph 5.8 and Table 5-4 describe all TMSCP end/errorlog packet codes.

Table 5-3. TMSCP FATAL ERROR CODES DEPOSITED INTO SA REGISTER

ERROR CODE OCTAL	ERROR CODE HEXADECIMAL	DESCRIPTION
100001	8001	Command packet read error (parity or timeout)
100002	8002	Response packet write error (parity or timeout)
100003	8003	Controller ROM and RAM parity
100004	8004	Controller RAM parity
100005	8005	Controller ROM parity
100006	8006	Ring read error (parity or timeout)
100007	8007	Ring write error (parity or timeout)
100010	8008	Interrupt failure
100011	8009	Host access timeout (TMSCP dependent)
100012	800A	Command limit exceeded (reporting this condition optional)
100013	800B	Bus Master error
100014	800C	Diagnostic controller fatal error
100015	800D	Instruction loop timeout
100016	800E	Invalid connection identifier
100017	800F	Error on interrupt write
100022	8012	RAM error (non-parity)
100023	8013	Port initialization sequence error
100024	8014	Wrong TMSCP version
100025	8015	Purge/poll hardware failure
100026	8016	Map table entry read error
100454	812C	TMSCP version number error
100455	812D	TMSCP hardware failure
100456	812E	Unknown interrupt
100457	812F	Own bit not set
100460	8130	Pulse AC Clear unsuccessful

Table 5-4. TMSCP STATUS AND EVENT CODES

MAJOR CODE NAME	MINOR OCTAL CODE	FULL OCTAL CODE	FULL HEX CODE	MINOR CODE NAME
Success (xxxx00)	0000	000000	0000	Normal success (no error)
	0010	000400	0100	Already on-line
	0040	002000	0400	EOT detected
Invalid command (xxxx01)	0000	000001	0001	Invalid MSG length
	0100	004001	0801	Invalid Opcode
	0120	005001	0A01	Invalid modifiers
	0140	006001	0C01	Invalid byte count or Invalid TMSCP version
	0160	007001	0E01	Invalid unit flags or Invalid controller flags
0400	020001	2001	Invalid format	
Command aborted (xxxx02)	No substatus codes apply			
Unit off-line (xxxx03)	0000	000003	0003	Unit unknown or on-line to another controller
	0001	000043	0023	No media loaded
	0002	000103	0043	Unit is inoperative
Unit available (xxxx04)	No substatus codes apply			
Unit write protected (xxxx06)	0200	010006	1006	Unit is software write protected
	0400	020006	2006	Unit is hardware write protected
	0600	030006	3006	Unit is software and hardware write protected
Compare error (xxxx07)	No substatus codes used			
Data error (xxxx10)	0000	000010	0008	Long Gap encountered
	0001	000050	0028	AGC fault
	0002	000110	0048	ID fault
	0003	000150	0068	Read data check
	0004	000210	0088	Unit exception
	0005	000250	00A8	FIFO Overrun/Overflow
	0006	000310	00C8	FMTR read parity error
	0007	000350	00E8	Unrecoverable read error

Table 5-4. TMSCP STATUS AND EVENT CODES (Cont'd)

MAJOR CODE NAME	MINOR OCTAL CODE	FULL OCTAL CODE	FULL HEX CODE	MINOR CODE NAME
	0010	000410	0108	FIFO parity error
	0011	000450	0128	I/F parity error
	0012	000510	0148	LESI parity error
	3773	177550	FF68	Formatter Retry sequence exhausted
	3774	177610	FF88	Controller transfer Retry limit exceeded
	3775	177650	FFA8	Host requested Retry suppression on a K.sti detected error
	3776	177710	FFC8	Reverse Retry currently not supported
	3777	177750	FFE8	Host requested Retry suppression on a formatter detected error
Host buffer access error (xxxx11)	0003	000151	0069	Nonexistent memory
	0004	000211	0089	Host bus/memory parity error
Controller error (xxxx12)	0000	000012	000A	Gross Time Out
	0001	000052	002A	Data late
Drive error (xxxx13)	0000	000013	000B	Device response check
	0001	000053	002B	Device hardware check
	0002	000113	004B	Velocity check
	0003	000153	006B	Device command check
	0004	000213	008B	Airflow/Temperature check
	3761	177053	FE2B	Could not save byte count
	3762	177113	FE4B	Could not write tape mark
	3763	177153	FE6B	Could not set unit characteristics
	3764	177213	FE8B	Unable to position to before LEOT
	3765	177253	FEAB	Rewind failure
	3766	177313	FECB	Could not complete On-line sequence
	3767	177353	FEEB	Erase Gap failed
	3770	177413	FF0B	Erase failed
	3773	177553	FF6B	Tape drive requested error log
	3776	177713	FFCB	Could not position for (Formatter) Retry
	3777	177753	FFE8	Cannot clear drive errors

Table 5-4. TMSCP STATUS AND EVENT CODES (Cont'd)

MAJOR CODE NAME	MINOR OCTAL CODE	FULL OCTAL CODE	FULL HEX CODE	MINOR CODE NAME
Formatter error (xxxx14)	0001	000054	002C	Equipment check
	0002	000114	004C	Intervention required
	0003	000154	006C	Command reject
	0004	000214	008C	Formatter response check
	0005	000254	00AC	Formatter sense read error
	3757	176754	FDEC	Could not get extended drive status
	3760	177014	FE0C	Could not get formatter summary status while trying to restore tape position
	3770	177414	FF0C	Topology command failed
	3773	177554	FF6C	Formatter requested error log
	3776	177714	FFCC	Cannot clear formatter errors
3777	177754	FFEC	Could not get formatter summary status during transfer error recovery	
BOT Encountered (xxxx15)	No substatus codes used			
Tape Mark detected (xxxx16)	No substatus codes used			
Recorded Data truncated (xxxx20)	No substatus codes used			
Position lost error (xxxx21)	3771	177461	FF31	Retry limit exceeded when attempting to restore tape position
	3773	177561	FF71	Formatter detected position lost
	3776	177721	FFD1	Formatter and controller disagree on tape position
	3777	177761	FFF1	Controller detected position lost

Table 5-4. TMSCP STATUS AND EVENT CODES (Cont'd)

MAJOR CODE NAME	MINOR OCTAL CODE	FULL OCTAL CODE	FULL HEX CODE	MINOR CODE NAME
Serious Exception Condition Present (xxxx22)				No substatus codes used
LEOT detected (xxxx23)				No substatus codes used

5.8 OPERATING SYSTEM ERROR LOG DECODING AND TROUBLESHOOTING

Status/error codes pass from the TMSCP server (in the TU81) to the TMSCP class driver (in the host). Hard TMSCP command errors, such as trying to read from a drive that is off-line, return a TMSCP error code in the command's end packet. Other nonfatal errors that occur during a command's execution return an error code in the command's end packet only if the error cannot be recovered after retries (hard).

Most of these nonfatal errors also try to send an error log packet to the host even if the error is recoverable or if there is a correlating TMSCP command. However, log packets are sent only if the host has explicitly enabled logging. The drive can send any combination of end/log packet status/error codes.

All status and error codes use the same format (Figure 5-37). A 5-bit major code occupies bits 04 through 00 and an 11-bit minor code occupies bits 15 through 05. (For TMSCP conventions, the major code is the device code and the minor code is the subdevice code.) Most of the error log report generators in Digital's operating system decode the packets and provide text descriptions for the major and minor codes. However, host-based diagnostics and utilities may provide only the numeric code. A full 16-bit code, or perhaps just the 11-bit minor component, may be provided.

Table 5-4 lists all major and minor codes the TU81 returns to the system. The table is broken into sections, and each major code occupies a section. The major codes are listed by name in numeric order. The minor codes and descriptions follow.

For example, if the system logs a 177713 (octal) error, reduce the code to a major code of 13 (bits 04 through 00) and a minor code of 3776 (bits 15 through 05). Now refer to the table. Major code 13 is a drive error. Under the drive error section, minor code 3776 is an error caused when the drive could not position for Retry.

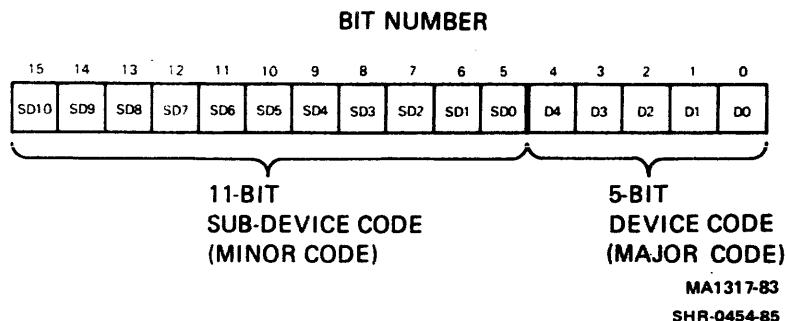

Figure 5-37. ERROR/STATUS CODE WORD FORMAT

5.9 TA81 HSC-EXECUTABLE DIAGNOSTICS

This section lists and describes all HSC-executable diagnostics that can be used to check out and accept the TA81 subsystem.

To run these diagnostics, mount and load a write-enabled 267 mm (10.5 in) tape reel. Place the transport on-line and make sure the on-line indicator lights. Depending on the STI port being driven, set the PORT SELECT A or B switch on the TA81 control panel to the enable (in) position.

To run HSC-executable diagnostics, you also need to boot the HSC. To do this:

1. Press the INIT button on the HSC. The following message displays:

```
INIPIO-I Booting...
```

The boot process takes about two minutes. When it is completed, this message appears:

```
HSC50 Version XXXX Date Time System n
```

2. Type Control Y. This prompt appears:

```
HSC50>
```

5.9.1 ILTAPE

The In-Line Tape Diagnostic (ILTAPE) is capable of running all of the drive resident formatter microdiagnostics from the HSC. A canned sequence, test 01, tests the TA81 transport functions. A second canned sequence, test 05, is available to check the transport's streaming functionality.

To run ILTAPE test 01, respond to each of the following prompts by entering the underlined command.

HSC50>R ILTAPE

ILTAPE>D>hh:mm Execution Starting
DRIVE UNIT NUMBER (U) []? Tnnn (nnn=unit number assigned)
EXECUTE FORMATTER DIAGNOSTICS (YN) [N]? N
EXECUTE TEST OF TAPE TRANSPORTATION (YN) [N]? Y
IS SCRATCH MEDIA MOUNTED (YN) [N]? Y
FUNCTIONAL TEST SEQUENCE NUMBER (D) [1]? 1
SELECT DENSITY (1-800, 2-1600, 3-6250) [3]? 3
DATA PATTERN (D) [3]? 3
ITERATIONS (D) [1]? 1 (One pass of ILTAPE test 01 will run.)

To run ILTAPE test 05, respond to each prompt by entering the same commands as those listed above until the following questions.

FUNCTIONAL TEST SEQUENCE NUMBER (D) [1]? 5
SELECT DENSITY (1-800, 2-1600, 3-6250) [3]? 3
ILTAPE>D>FIXED SPEEDS AVAILABLE:
ILTAPE>D> (1) 025 IPS
ILTAPE>D> (2) 075 IPS
SELECT FIXED SPEED (D) [0 = AUTOMATIC]? 0
DATA PATTERN NUMBER (D) [3]? 3
ITERATIONS (D) [1]? 1 (One pass of ILTAPE test 05 will run.)

5.9.2 ILEXER

The In-Line Exerciser Diagnostic (ILEXER) exercises from 1 to 10 units in any combination of disk and tape drives connected to an HSC. Logic is tested by writing and reading predetermined data patterns and recording modes. Table 5-5 lists the acceptable error criterion for one pass of ILEXER, using the GCR worst case data pattern (22) for a 2400 foot reel of tape.

Table 5-5. MAXIMUM ERROR NUMBER

ERROR TYPE DESIGNATION	DESCRIPTION	ALLOWED NUMBER (PER PASS OF 2400 FT REEL)
Hard	Nonrecoverable	0
Media	Tape media	20
Double Trkerr	Double track correction (read)	1
Double Trkrev	Double track correction (read reverse)	*
Single Trkerr	Single track correction (read)	5
Single Trkrev	Single track correction (read reverse)	*
Other Err A	Other (read)	10
Other Err B	Status	*
Other Err C	Other (write)	10

* Indicates designations not used by TA81. Headings appear on error report, but these designations always report 0 errors.

NOTES:

1. Other (read) - successful operation without error correction, but with interesting occurrence (AMTIE or PHTIE flag).

Other (write) - write retry succeeded in same physical location that previous write retry failed.
2. If the TA81 does not meet these specifications, additional run time is needed to determine the validity of errors.

5.10 ASCII PORT DIAGNOSTICS

When connected to a handheld or console terminal, the ASCII port (Figure 5-38) serves as an input/output device to perform the following functions.

1. Run the transport resident diagnostics
2. Display or print out error log information (sense bytes)
3. Run special test 27 (conversation mode test using selective parameters)

NOTE

Paragraph 4.10.1.3 lists the sense bytes and ASCII addresses.

The ASCII port is on the left side of the TU81 control panel (under the cover). To use the port, open the cover and plug in an RS232-compatible terminal into the EIA 25-position terminal I/O connector.

NOTE

The ASCII port accepts and generates the full ASCII character set. Certain characters are ignored or have special meaning as defined in Table 5-6.

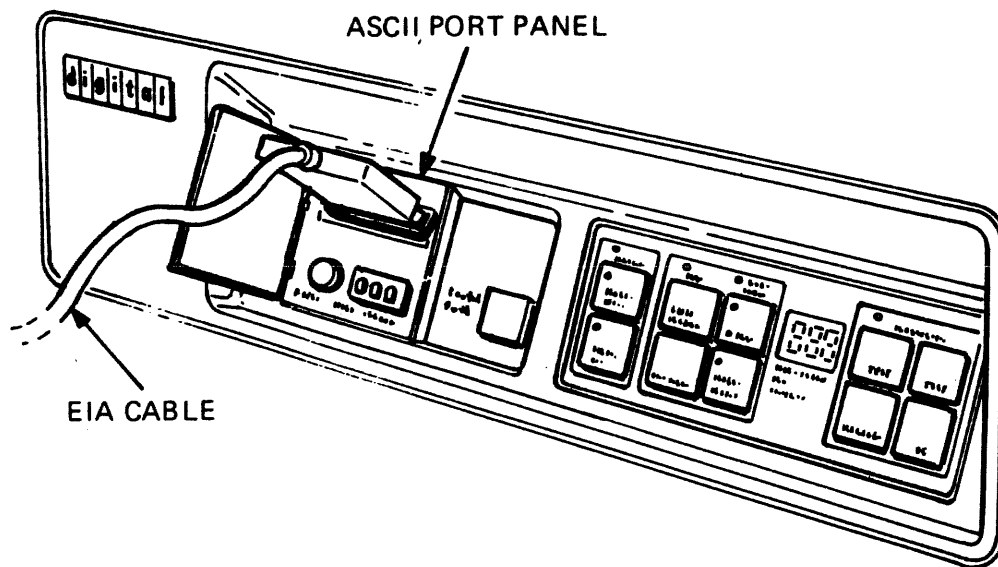

MA-1173-83

Figure 5-38. ASCII PORT AND EIA CABLE

Table 5-6. CONTROL COMMANDS

CONTROL CHARACTER	DESCRIPTION
CONTROL/C (ETX) CONTROL/Y (EM)	Gains the attention of the ASCII control program. Other commands may follow. It can also be issued to abort the run of the current command, program, or diagnostic.
CONTROL/G (BEL)	When received by the terminal, causes an audible sound (BELL) from the terminal. The ASCII control program treats it as an illegal character.
BACKSPACE (BS) or CONTROL/H	When received by a video terminal, overwrites the previously displayed character.
LINEFEED (LF) or CONTROL/J	Starts any line of text output.
RETURN (CR) or CONTROL/M	Signals the end of an input line.
CONTROL/O (SI)	Toggles the output to the ASCII terminal on or off. With the output toggled off, the characters sent to the terminal do not display. The program continues to run.
XON (DX1) or CONTROL/Q	Generated by the terminal to start the output aborted by the previous CONTROL/S.
XOFF (DC3) or CONTROL/S	Generated by the terminal to stop the ASCII control program from sending characters to it. The program generating the output stops running until a CONTROL/Q is received.
CONTROL/U (NAK)	Generated by the terminal to tell the ASCII control program to delete and abort the current input and reissue the command prompt.
CONTROL/Z (SUB)	Generated by the terminal to signal the end of a transaction. If this command is entered at the command prompt, the ASCII control program ignores further terminal input, reversing the initial CONTROL/C or /Y command.

Table 5-6. CONTROL COMMANDS (Cont'd)

CONTROL CHARACTER	DESCRIPTION
DELETE (DEL)	Generated by the terminal to erase the previously entered character. On a video terminal, in the default mode, DELETE is echoed as BACKSPACE, SPACE, BACKSPACE. On a hardcopy terminal (set up with the command SET TERMINAL/NOSCOPE or /HARDCOPY), DELETE is echoed as \, echo of deleted characters, \. DELETE does not delete past the end of the prompt.

NOTE

The ASCII port's control program generates no special characters except CONTROL/G, indicating an illegal input character; and CONTROL/J and CONTROL/M for formatting the output. Any control character not mentioned in this table as valid input generates BELL if received.

5.10.1 Port Access

To communicate with the ASCII port, proceed as follows.

1. Take the TU81 off-line from the host system.
2. Type CONTROL/C or CONTROL/Y. Characters typed earlier are ignored.
3. Mount a scratch tape and enter CONTROL/M (or RETURN) to continue the operation.
4. The ASCII port's control program gives the command level prompt, indicating it is ready for an input command. The prompt is TU81>.
5. Enter a command from Table 5-7. If you want to run the transport diagnostics, enter the default RUN DIAGNOSTICS command or RUN DIAGNOSTICS/TEST=xx to run a particular test (for example, from the TU81/TA81 Pathfinder). Refer to Paragraph 5.10.2 to set up specific options.
6. If the test is successful, the terminal responds with the TU81> prompt. If the test fails, the terminal displays the diagnostic message specifying the fault condition. (Refer to Paragraph 5.10.3.)
7. Type CONTROL/Z or EXIT to exit from the ASCII terminal mode. The TU81 echoes with ^Z.

Table 5-7. OPERATING COMMANDS

COMMAND	DESCRIPTION
SET TERMINAL	<p>/SCOPE -- (Default) indicates that the terminal in use is a video display terminal.</p> <p>/HARDCOPY or /NOSCOPE -- Indicates that the terminal in use is a hardcopy (printing) unit.</p>
SET DIAGNOSTIC	<p>/LOOP -- Enables loop-on-error mode.</p> <p>/NOLOOP -- (Default) Disables loop-on-error.</p> <p>/HALT -- Enables halt-on-error; exits to TA81> prompt ending the test.</p> <p>/NO HALT -- (Default) Disables halt-on-error.</p>
SHOW DEVICE	Displays the device unit type and device serial number.
SHOW RADIX	Displays the number base of numeric outputs; in TA81s the radix is decimal.
SHOW VERSION	Displays the hardware and microcode version levels.
RUN DIAGNOSTICS	(Default) Starts the power-up diagnostic test.
RUN DIAGNOSTICS/ TEST=xx	Selects a diagnostic test number where xx represents two decimal digits.
EXIT	Exits the TA81 from the terminal mode. After exit, the TA81 no longer responds to the external ASCII terminal except for the CONTROL/C input command.
CONTROL/Z	Same as EXIT, echoes with ^Z. Also, used to return the SET mode to default values.

The control program disconnects after 10 idle minutes if there is no input at the command prompt level. Any characters typed in before the TU81> prompt are ignored.

5.10.2 Diagnostic Commands

The diagnostic commands check the TU81 status, and set up and control the diagnostic execution. To set a diagnostic control parameter, enter the proper SET command before starting the test. Once specified, the parameter stays in effect until changed with another command or until you exit from the terminal mode.

If no SET parameters were specified, the ASCII control program automatically uses the default parameters, which remain active until you use a SET command. For example, you can run the selected test with "no loop on error" and "no halt on error" defaults. In this case the test runs for one pass only.

Type diagnostic commands immediately after the prompt with no spaces between. Separate the command from the first parameter by one space. If you invoke options, enter them after the first parameter, with a slash between the two terms. One option per command is allowed.

5.10.3 Message Format

Each input line together with the command prompt should not be greater than 64 characters. Characters beyond the 64th are ignored by the control program. All inputs from the terminal (except CONTROL/C and /Y) are prompted.

Diagnostic Messages

Diagnostic results are reported in the following format if the test is unsuccessful (maximum 64 characters per line).

TEST:xx FAULT CODE:xx FAULT SUBCODE:xx

where

TEST:xx	=	Diagnostic test number (in decimal)
FAULT CODE:xx	=	Code indicating primary field replaceable unit
FAULT SUBCODE:xx	=	Code indicating hardware element that failed

Successful completion of a diagnostic test causes the prompt to display. Refer to the TU81/TA81 Pathfinder tables for additional instructions in the event of a diagnostic failure.

5.10.4 Special Diagnostic Test 27

Test 27 is not a resident microdiagnostic permanently stored in the TU81 memory. This diagnostic can only be performed using a terminal since it requires manual data input.

Test Procedure

Put unit on-line.

Enter the command

```
|||RUN DIAGNOSTICS/TEST=27|||.
```

This causes three commands to be run in the following order.

1. Write
2. Backspace
3. Read

When the prompt appears on the terminal, enter the first input parameter, selecting speed and density. As each additional prompt appears, enter additional input parameters in the specified order.

```
|||TU81> ||| Speed and density select where  
1 = 25 ips PE  
2 = 75 ips PE  
3 = 25 ips GCR  
4 = 75 ips GCR
```

```
|||TU81> ||| Pattern identifier where  
1 = all ones  
2 = all zeros  
3 = alternating bytes of ones and zeros  
4 = worst case PE pattern  
3 1s  
2 0s      byte 1  
3 1s  
  
3 0s  
3 1s      byte 2  
3 0s
```

```
|||TU81> ||| Bytes/block where  
1 = 512 bytes  
2 = 2048 bytes
```

```
|||TU81> ||| Write block count: XXX where  
XXX = 0 to 255
```

```
|||TU81> ||| Backspace block count: XXX where  
XXX = 0 to 255
```

```
|||TU81> ||| Read block count where  
XXX = 0 to 255
```

Example:

Entering the following causes 16 blocks of 2048 bytes of ones to be written at 25 ips PE. Then a backspace of 16 blocks occurs, and the 16 blocks are read.

```
TU81> 1
TU81> 1
TU81> 2
TU81> 16
TU81> 16
TU81> 16
```

If you enter zero in a block count field, the corresponding command is not run.

Enter all parameters as decimal numbers.

After receiving the input parameters, the TU81 performs a rewind to BOT. This is necessary because a density change can only be made when the tape is positioned at BOT.

Default Parameter Values

If you type CONTROL/Z immediately after entering:

```
RUN DIAGNOSTICS/TEST=27
```

the input parameters revert to these default values.

Speed and density select	1	(25 ips PE)
Pattern identifier	3	(alternating ones and zeros)
Bytes/block	1	(512 bytes)
Write block count	10	
Backspace block count	10	
Read block count	10	

If you enter CONTROL/Z during parameter selection, default values are assumed for the remaining parameters.

System Conflicts

If the unit is on-line to the host when the ASCII port is activated, the following message displays on the terminal.

```
TU81 ONLINE TO HOST.
TO USE ASCII PORT, TAKE UNIT OFFLINE!
```

APPENDIX A - TU81 SYSTEM INTERFACE

A.1 TMSCP OVERVIEW

The TU81 tape subsystem conforms to the DIGITAL Mass Storage Control Protocol (MSCP). MSCP is an asynchronous communications protocol. Tape-oriented MSCP (TMSCP) is the asynchronous I/O communication protocol used by a family of tape mass storage device controllers. TMSCP conforms to general MSCP. Commands and responses are exchanged between the Host and TMSCP Interface/Controller by messages structured with a general format. Data I/O is performed over the Unibus and Low End Storage Interconnect (LESI) comprised of a set of I/O cables and KLESI-UNIBUS adapter (M8739). The TMSCP Interface/Controller modules contains the intelligence under microprocessor control to convert these messages to TU81 device specific Commands and Responses. The MSCP concept allows future devices to be interfaced to the Host without requiring new Host-based driving software.

LEGAL NOTICE

TMSCP and STI protocols and documentation are the proprietary information of Digital Equipment Corporation. UNIBUS/Q-BUS/BI-BUS port drivers and documentation for MSCP/TMSCP products are also proprietary information of Digital Equipment Corporation.

A.2 SUBSYSTEM OVERVIEW

Figure A-1 is a block diagram of the TU81 subsystem. The tape transport is directly connected to a VAX CPU by a UNIBUS/LESI interconnect. The LESI adapter (M8739) resides in any small peripheral controller slot in the UNIBUS backplane. The LESI relieves the Controller of UNIBUS overhead such as supervising NPR transfers and generating interrupts. It also simplifies communication with the I/O page registers.

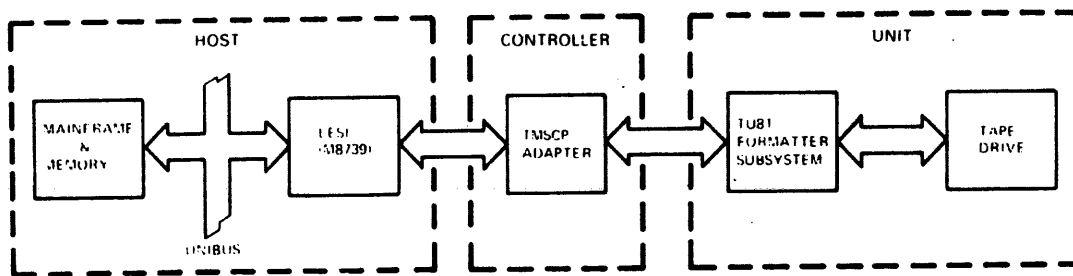

Figure A-1. TU81 SYSTEM BLOCK DIAGRAM

The TMSCP Adapter contains the Controller interface to the LESI, the interface to the Formatter and the microprocessor-based intelligent controller. The Controller fetches and translates Host-transmitted command messages to TU81 Formatter commands. It also encodes TU81 Formatter and drive status into messages and delivers them to the Host. In addition, it supervises bi-directional data transfer between the Host and Unit.

The Formatter receives commands from the from the Controller and converts them to motion and data transfer operations to the drive. Data received from the Host via Controller is converted to PE or GCR format and passed on to the drive. Data received from the drive is error corrected, converted and passed to the Host through the Controller.

The Tape Drive is the physical transport itself with the read/write electronics, servo control and panel switches. For purposes of MSCP definition, the Formatter and drive are defined as the 'Unit' and the TMSCP Adapter as the 'Controller'.

A.3 SOFTWARE/FIRMWARE OVERVIEW

In a computer system that uses an MSCP mass storage subsystem, the I/O controller in the peripheral device contains the intelligence to perform the detailed I/O tasks. This arrangement allows the Host to simply send command messages (such as requests for reads and writes) to the I/O controller and to receive responses messages back from the controller. The Host does not concern itself with the details such as device type, media geometry and format, error recovery, etc.

A.3.1 Host Architecture

The Host uses two layer of software to communicate with the tape subsystem. They are a "class driver" and a "port driver". The class driver is the higher software layer and is concerned with the tasks to be performed. The class driver's knowledge of details is limited to the general device class (such as disk or tape) and the capacity of the device. The class driver is not concerned with the communication link (I/O bus and adapter), controller or the exact model of the device being used.

The port driver is the lower software layer that is concerned only with communication services such as passing the messages over the communication link. The port driver is not aware of the messages' meaning and is not concerned with the exact type of the I/O controller or the storage unit. However, it is tailored to the type of I/O bus used in the subsystem. The LESI-UNIBUS adapter is driven by a UNIBUS port driver. Each driver (software layer) has its own level of responsibilities and shields the other from unnecessary load and details.

A.3.2 I/O Controller Architecture

In the device I/O controller, there are also two corresponding levels of software. The lower of these two is also a port driver and like the port driver in the Host, is only concerned with passing messages back and forth over the communication bus.

The higher layer of controller software is a "TMSCP Server". It constitutes the intelligence of the I/O controller and therefore defines its functionality. The TMSCP Server concerns itself with determining the number of devices, their type, geometry, unit number, availability, status, etc. The TMSCP Server receives requests from and sends responses to the Host. It optimizes the requests, performs the data handling and data I/O operations, and saves the data in the buffer if necessary.

The TMSCP Server performs error detection and recovery, and reports any significant errors to the Host. Because of this function, the Host sees a "perfect media", an important characteristic of an MSCP subsystem. That is, the Host only needs to report the errors to the higher level (user) software, as the TMSCP Server performs all error recovery and media defect (bad block) handling.

Figure A-2 is the software/firmware block diagram of the subsystem. The following paragraphs summarize the operation of each block.

The Class Driver performs the following functions:

1. Establishes a connection with the TMSCP Server via the Host and Controller Port Driver.
2. Builds commands in Message Format to be delivered via the Port Driver to the TMSCP Server.
3. Receives Response Messages from the TMSCP Server via the Port Driver.
4. Interrogates the status from the Response Messages.
5. Establishes the data buffer via the Host Port Driver for bi-directional data transfer between Host Memory and Tape Drive.

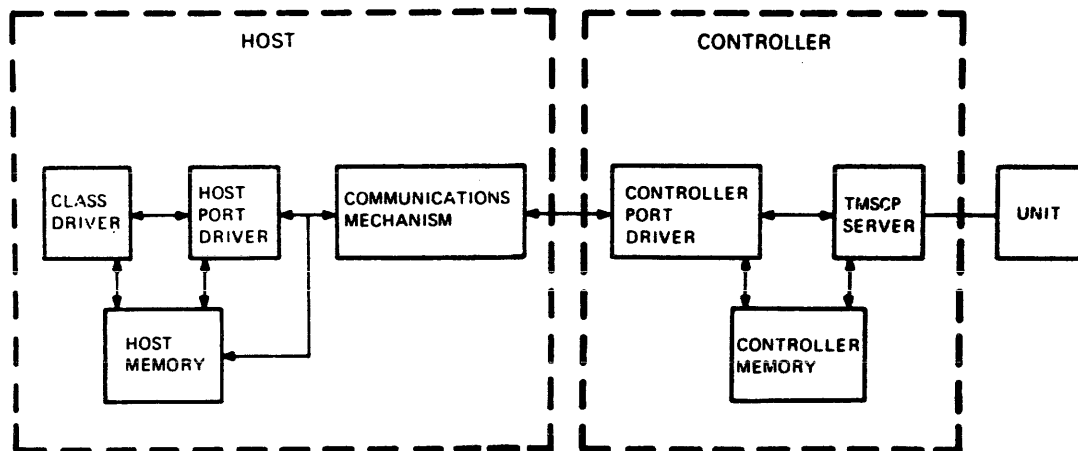

MA 0917 BA

Figure A-2. SOFTWARE/FIRMWARE BLOCK DIAGRAM

The Host Port Driver performs the following functions:

1. Initializes synchronization of the connection between the Class Driver and the TMSCP Server via the Controller Port Driver.
2. Supervises the integrity of the connection by monitoring the communication mechanism for error conditions and re-establishes connections on Power Fail.
3. Establishes and supervises the communications area in Host Memory for bi-directional message transfers between the Class Driver and TMSCP Server.
4. Maintains control of the data buffer in Host Memory under direction from the Class Driver.
5. Maintains Flow Control of commands to the TMSCP Server.

The Communications Mechanism is the hardware, physical interconnect between the Host and the TU81 tape transport. It consists of the UNIBUS, the LESI adapter and associated logic in the Host and Controller to support the Host and Controller Port Drivers.

The Controller Port Driver performs the following functions:

1. Responds to and supports the Host Port Driver initialization to establish the connection between the Class Driver and the TMSCP Server.
2. Performs diagnostic functions in the communications mechanism and in the Controller to support the Host Port Driver in maintaining the integrity of the connection.
3. Reports and defines all fatal error conditions detected during the operation of the port.
4. Supervises delivery and receipt of Command and Response messages from the Host Port Driver.
5. Supervises the Controller portion of bi-directional data transfers between the Tape Transport and Host Memory.

The TMSCP Server performs the following functions:

1. Receives Command Messages from the Class Driver via the Port.
2. Translates and interprets Command Messages into TU81 Function Commands.

3. Transmits TU81 Function Commands to the Formatter.
4. Receives status information from the Formatter.
5. Encodes Formatter and Drive status information into Response Messages to be delivered by the Controller Port Driver.

A.4 HOST TO CONTROLLER COMMUNICATIONS

The Host's class driver and the controller's TMSCP server route their messages through the path of corresponding port drivers and a hardware interconnect layer. The hardware interconnect (physical realization of the communication link) is the communication mechanism. This communication takes place across a link called a "connection" (Figure A-3).

A.4.1 Connection States

The state of the connection is directly equivalent to the state of the controller of TMSCP server with respect to the class driver. Controller states are as follows:

- o CONTROLLER-ONLINE - only if the connection is established and functioning.
- o CONTROLLER-AVAILABLE - the connection is NOT established but it is believed that it CAN be established.
- o CONTROLLER-OFFLINE - the connection is NOT established and it is believed that it CANNOT be set.

Three types of communication services are used across the connection between a class driver and a MSCP server:

- o Sequential Message Communication Service for MSCP control messages.
- o Datagram Communication Service for MSCP error log messages.
- o Block Data Communication Service for data transfer between a Host and device controller. That is, the contents of a named buffer on one side of the link are transferred to a named buffer on the other side of the link.

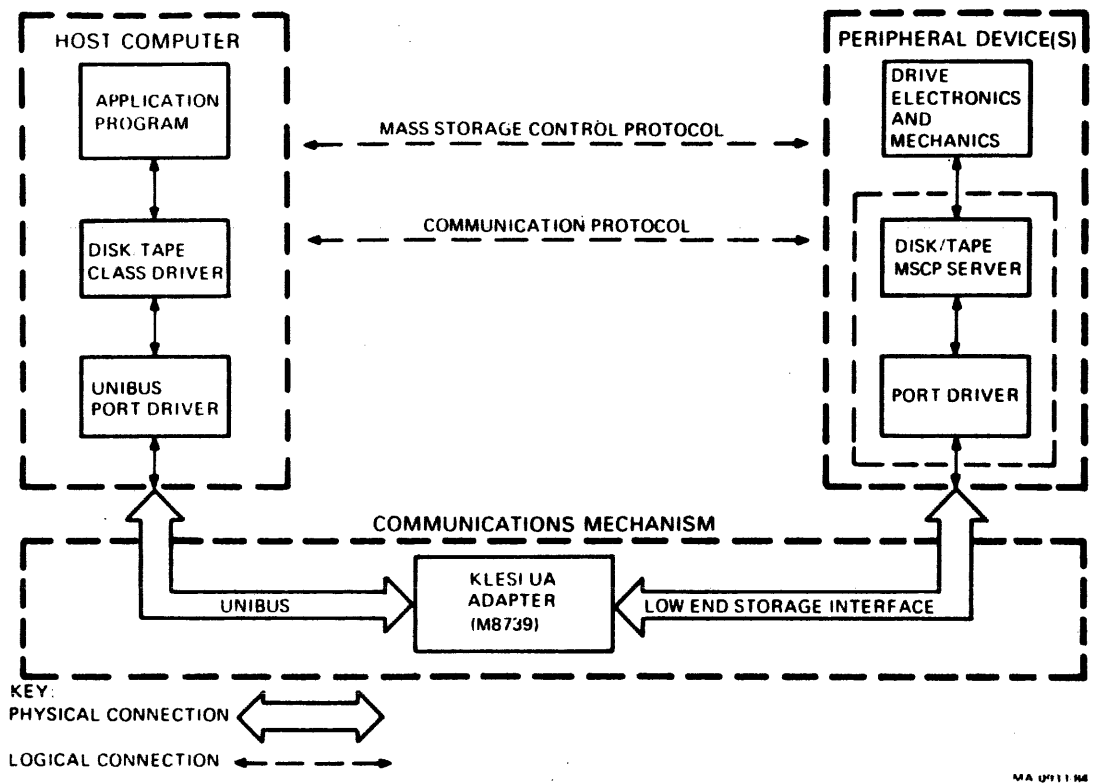

Figure A-3. COMMUNICATIONS MECHANISM

A Unit (i.e. TU81 Formatter) can be in one of three states relative to each class driver (in a Host) that is "CONTROLLER ONLINE" to an I/O controller (TMSCP server). The unit states are:

- o UNIT-OFFLINE - If a formatter is OFFLINE to an I/O controller, the addressed tape transport connected to the offline controller is also offline to a host.
- o UNIT-AVAILABLE - Tape transport must be powered up, online to the formatter, have a tape loaded, and be ready to perform I/O when the Host brings it online.
- o UNIT-ONLINE - With the formatter and the controller both online, the transport is ready and able to satisfy normal host requests and the Host has issued a successful ONLINE command.

A.4.2 Flow Control

Especially critical to MSCP is the concept of Flow Control which is used to control, buffer, and handle the data flow.

Flow Control provides data buffering and overflow control for sequential message and block data communication services. The datagram communication service does not use flow control. If no buffers are available, the incoming datagrams will be discarded. The probability of datagram delivery is based on the ability of the receiver (i.e. the class driver) to always have the buffers queued for incoming datagrams.

When a potential receiving process queues a buffer for receiving messages on a connection, the presence of this buffer is transmitted (via the underlying communications service) to the potential sending process at the other end of the connection. This message, while notifying the potential sender of the queued buffer, grants the sender a credit, which is the privilege to send the message. Therefore, the messages will only be sent when the sender knows that the receiver has queued a buffer with enough capacity to receive the messages.

Typical implementation of the flow control is based on the use of a counter in the port driver which holds the process credit balance for each partner involved in the communication process; that is, the number of queued receive buffers minus the number of messages that have been sent. Every time the process's partner queues the receive buffer, a message is sent causing the counter to be incremented. Every time the message is sent, the counter is decremented. The messages may only be transmitted when the counter (credit balance) is greater than zero.

A.5 M8739 LESI ADAPTER

The M8739 LESI UNIBUS Adapter is a quad height module which plugs into any small peripheral controller slot in the UNIBUS backplane. It interfaces the UNIBUS to the intelligent controller in the transport. The M8739 performs the following functions:

1. Enables the I/O controller to send and receive data (via Direct memory access) to and from the Host's memory.
2. Enables the I/O controller to interrupt the Host.
3. Enables access to two UNIBUS registers - Initialization and Polling (IP), and Status, Address and Purge (SA).

In the LESI Interconnect, the M8739 is always a slave to the controller. The controller initiates all operations and the adapter response upon completion of the command or data block transfer.

Figure A-4 is the M8739 Block Diagram.

A.5.1 Data Transfers

Before initiating an NPR, the controller writes the host starting address for the NPR into the address register. The controller initiates the NPR by writing into the command register: Do an NPR, with a direction bit and the word count. The address register increments with each data transfer occurring on the host interface.

The M8739 transfers data to and from the controller in blocks of 16 words. Multiple block transfers occur without reissuing the command or rewriting the starting address (except in Byte Mode). This is done by transferring 16 more data words into or from the adapter RAM. The DO NPR command restarts when an overflow of the word count is detected by the adapter. Each successive block transfer must start at RAM address 0 and be 16 words long. If a shorter block has to be transmitted at the end of the burst, DO NPR is cleared first, then the word count is modified before the controller reissues DO NPR and sets up the RAM. Multiple block transfers can be prevented by clearing DO NPR at the end of each block transfer.

Byte operation occurs in single byte transfers at the beginning and end of a record. All data inside the record is in word format and all word transfers are executed in block sizes specified by the Host. The adapter gives up the Host bus at the end of every byte transfer. Therefore, after each single byte transfer, the controller writes the starting address and issues a new command.

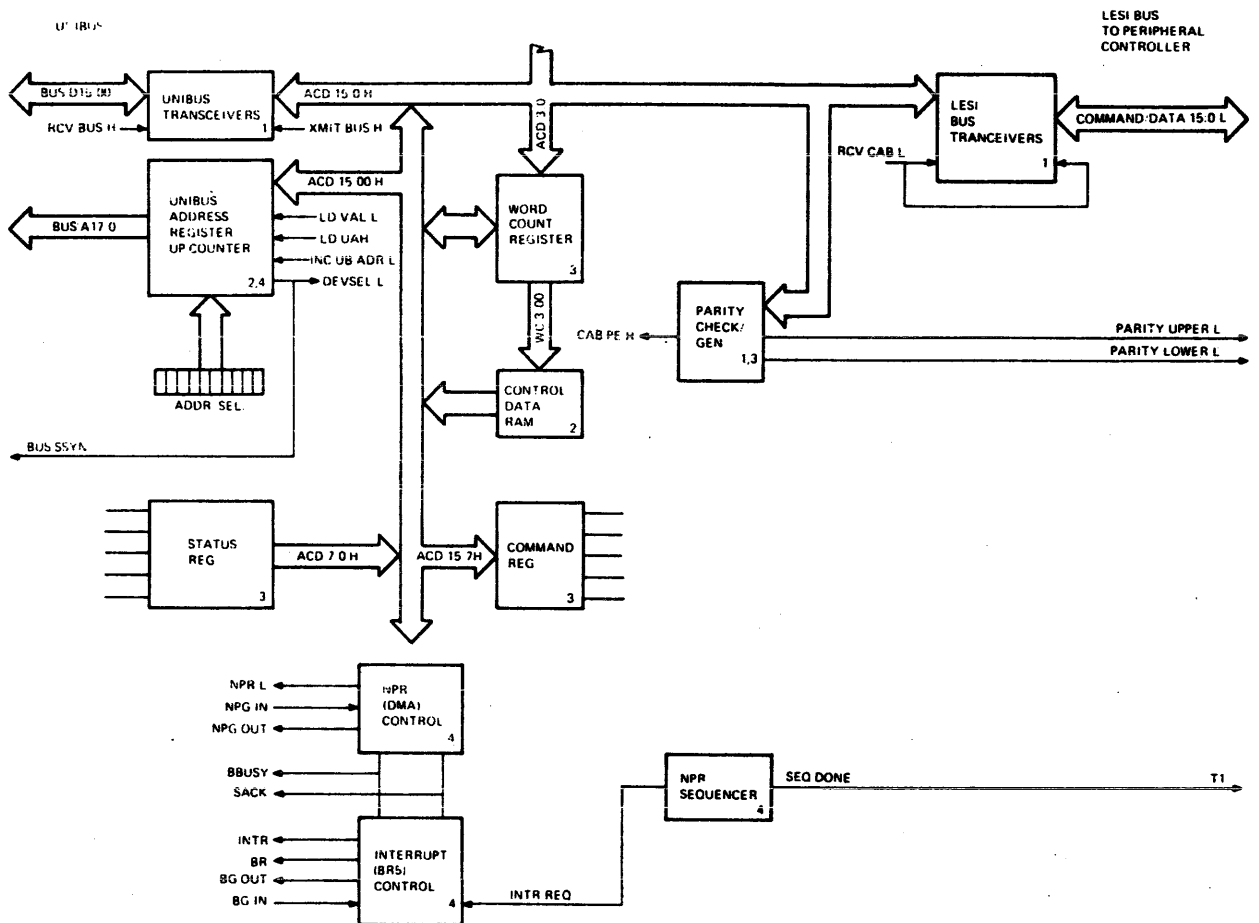

Figure A-4. M8739 LESI ADAPTER BLOCK DIAGRAM

Parity is generated and checked on both the controller and the host interfaces. The adapter informs the controller of the completion of the data block transfer by asserting ATTENTION.

A.5.2 Interrupts

The adapter card also executes Host interrupts. First, the controller writes the interrupt vector into RAM location zero, then initiates the interrupt by writing into the command register the DO INTERRUPT command with zero address and word count bits.

A.5.3 UNIBUS Registers

The M8739 adapter also operates as a slave device to the host when it runs from the TMSCP Controller. The adapter holds the addresses of two UNIBUS registers, Initialization and Polling (IP) and Status, Address and Purge (SA) which are used for control of the port.

o IP Register Function

1. Host write to IP causes a "hard" initialization of the port and controller.
2. Host read from IP (when the port is operating) sets POLL bit in the adapter status register.

o SA Register Function

1. Host write to SA during initialization sends host specific parameters to the port (adapter and controller).
2. Host read from SA during initialization gets data/error information relating to the initialization process.
3. Host read from SA during normal operation gets status and fatal errors.
4. Host write zeros to SA during initialization or normal operation signifies a successful adapter purge in response to a port initiated purge request.

A.6 TMSCP CONTROLLER MODULE

Figure A-5 is a block diagram of the TMSCP Controller Module. The LESI Interface is the interconnect between the TMSCP Card and the Host. The Formatter Interface is the interconnect between the TMSCP Card and the TU81 Formattter. The Microprocessor Controller on the TMSCP Module contains the Microprocessor RAM Memory, ROM Memory and support logic to execute the translation of MSCP protocol to TU81 specific functions.

Figure A-6 is a block diagram of the Microprocessor Controller. The Microprocessor controls the execution of the Controller Port Driver Firmware and the TMSCP Server Firmware. It also controls all hardware I/O via the PIAs and Latency Buffer. The 16K x 9 ROM Memory contains the microcode for the TMSCP Server and Port Driver as well as additional functionality required internally. The 1K x 9 RAM Memory provides temporary storage for Command Packets, End Packets and Error Log Messages. It also provides scratch pad memory to support the ROM-based firmware.

A.7 THE UNIT

The rest of the TU81 Subsystem is referred to as the Unit. Figure A-1 is a functional block diagram of the TU81.

Refer to paragraphs 4.9 and 4.10 of this manual for information on Formatter modules and interface signals.

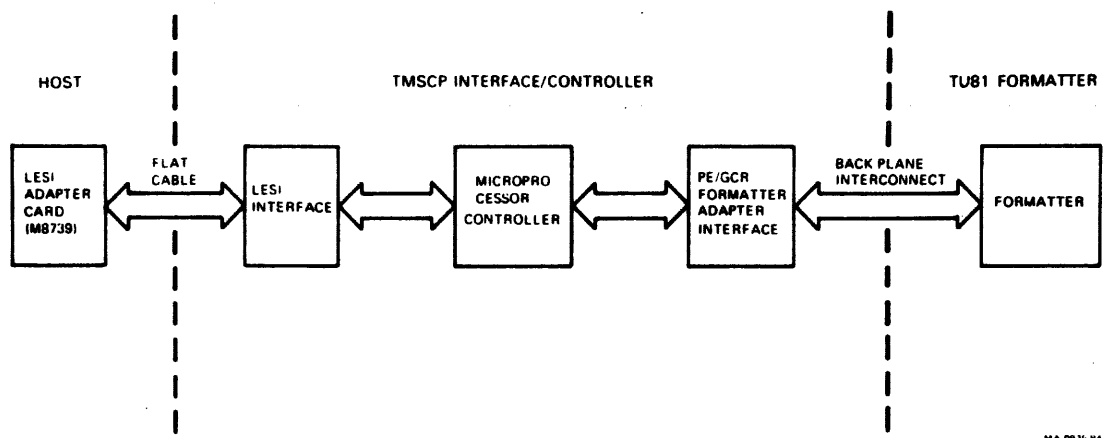

Figure A-5. TMSCP INTERFACE BLOCK DIAGRAM

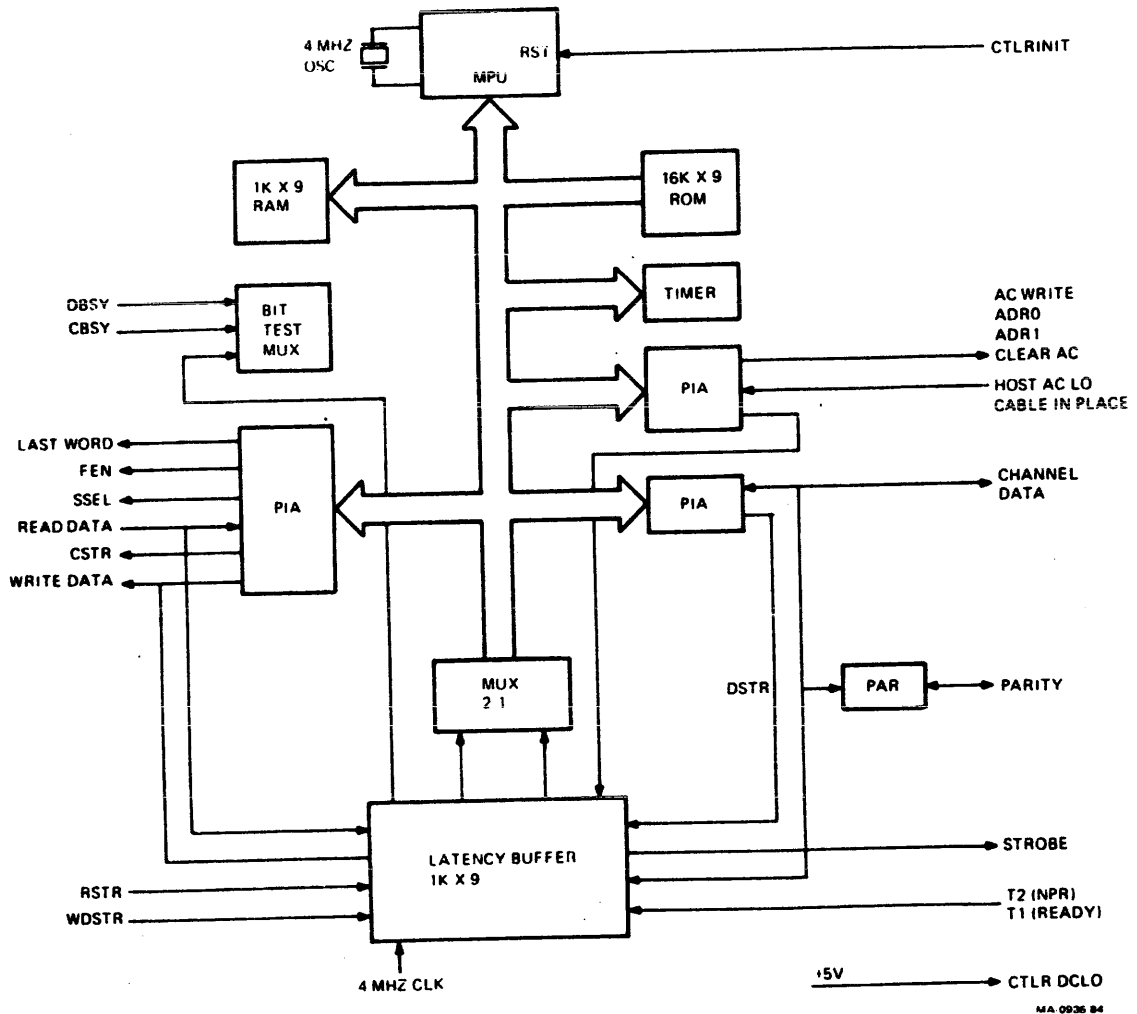

Figure A-6. TMSCP CONTROLLER BLOCK DIAGRAM

APPENDIX B

B.1 TAPE TRANSPORT CONFIGURATION SELECTION

The TU81/TA81 has optional features and selectable addresses. Option and address selection components are contained on the Interface, Formatter Write, and Servo/Control Modules. Table B-1 lists these features and their associated jumpers and switches. Refer to Figure B-1 for component locations.

Table B-1. TU81/TA81 CONFIGURATION

OPTION	JUMPER/SWITCH	FUNCTION
<u>INTERFACE MODULE</u>		
Channel Parity Check	W1 (1-2)	Parity bit not transferred with data from host.
	W1 (2-3) As Shipped	Parity bit transferred with data from host.
Remote/Local Density *	W3 (1-2)	Remote Density Select
	W3 (2-3) As Shipped	Local Density Select
Adaptive Velocity Control (AVC) **	W5 (1-2) As Shipped	AVC Enabled
	W5 (2-3)	AVC Disabled
Density Status Option	W6 (1-2) As Shipped	Density Status Enabled
	W6 (2-3)	Density Status Disabled
Formatter/Device Address Select Switches S1 to S4	S1-OFF	
	As Shipped	Formatter Address 0
	S1-ON	Formatter Address 1
	S2-OFF, S3-OFF	
	As Shipped	Transport Address 0
	S2-OFF, S3-ON	Transport Address 1
S2-ON, S3-OFF	Transport Address 2	
S2-ON, S3-ON	Transport Address 3	

Table B-1. TU8A/TA81 CONFIGURATION (Cont'd)

OPTION	JUMPER/SWITCH	FUNCTION
<u>FORMATTER WRITE MODULE</u>		
Long Gap Select (PE)	W1 (1-2) As Shipped W1 (2-3)	Variable Gap-0.6" to 1.2" Fixed Gap-1.2"
Short Gap Select (PE)	W2 (1-2) As Shipped W2 (2-3)	Variable Gap-0.6" to 0.9" Fixed Gap-0.6"
Long Gap Select (GCR)	W1 (1-2) As Shipped W1 (2-3)	Variable Gap-0.3" to 0.6" Fixed Gap-0.6"
Short Gap Select (GCR)	W2 (1-2) As Shipped W2 (2-3)	Variable Gap-0.3" to 0.45" Fixed Gap-0.3"
Long Gap or Short Gap selection is made by means of I/O interface line <u>FLGAP</u> .		
Spare	W3	
<u>SERVO/CONTROL MODULE</u>		
Write to EEPROM	W1 (1-2) W1 (2-3) As Shipped	Active Inactive

* If the transport is configured in the local density mode (W3, no jumper) and tape is positioned at BOT, alternately pressing of the LOAD/REWIND switch will cause the unit to alternately change density from PE to GCR and vice versa. The HIGH DENSITY indicator lights when GCR is selected.

** Jumper W5 - Adaptive Velocity Control. When this option is used, rather than selecting 25 ips mode when low speed is commanded, the transport enters a mode whereby the optimum speed is chosen to match system requirements. If 75 ips mode gives the best throughput, then this mode is used; the same applies to 25 ips streaming and 25 ips start/stop modes if the unit is in the PE mode. This choice of operating mode is made automatically by the transport and does not require any involvement by the system.

The diagrams (Figures B-1 through B-5) are intended to help service personnel find and service the electronic modules.

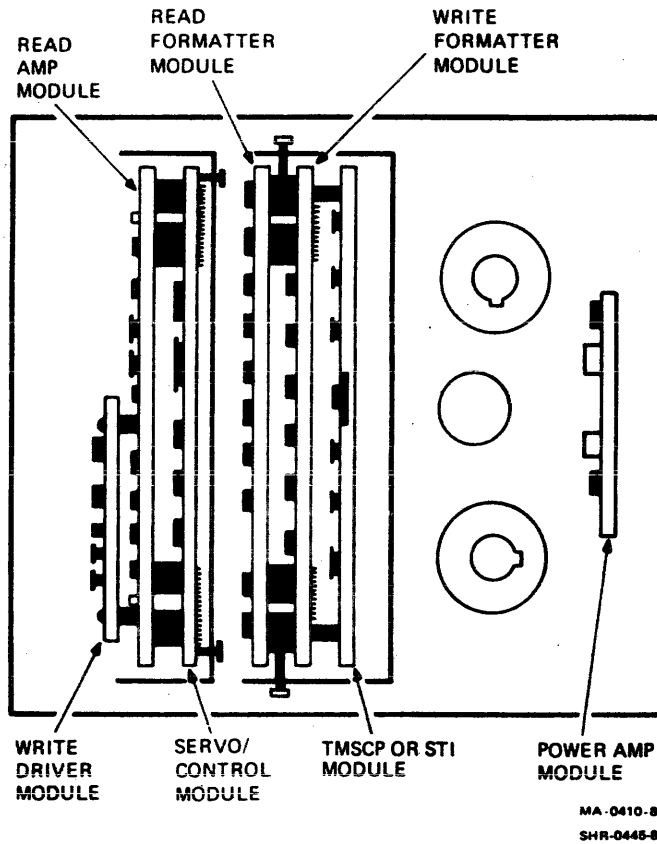
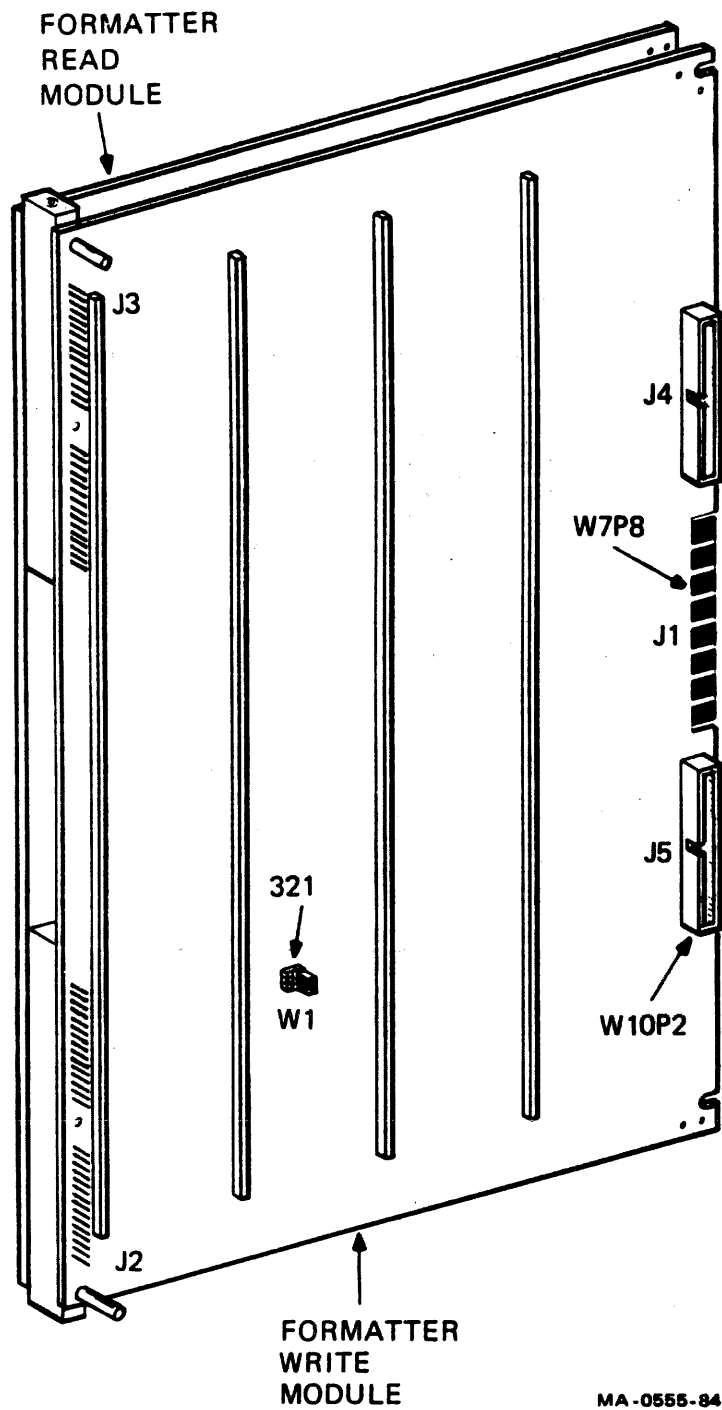

Figure B-1. LOGIC MODULE LOCATIONS WITH TAPE DECK IN SERVICE POSITION



MA-0555-84

Figure B-2. FORMATTER WRITE MODULE - JUMPER LOCATIONS

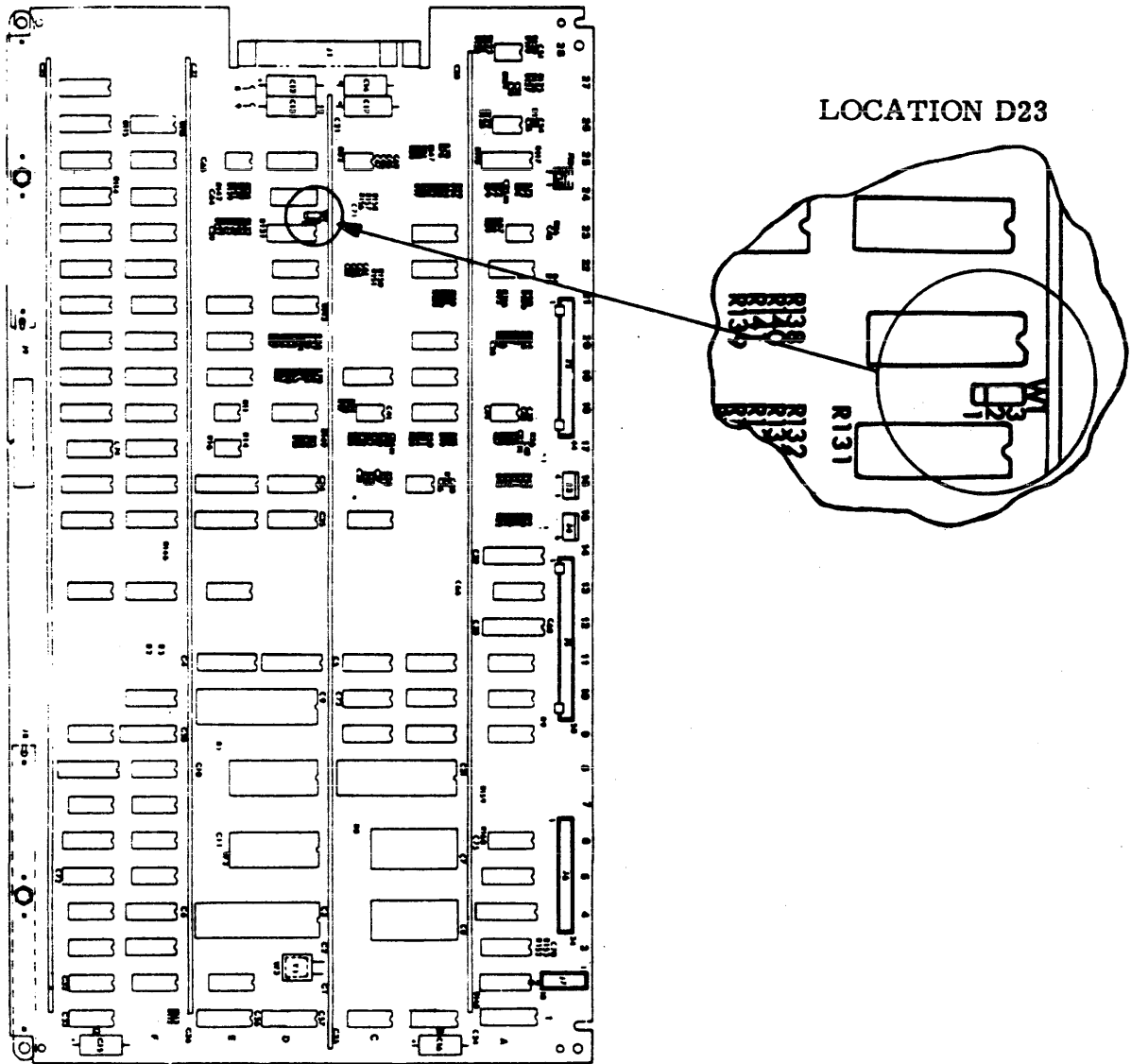

Figure B-3. SERVO/CONTROL MODULE - JUMPER LOCATIONS

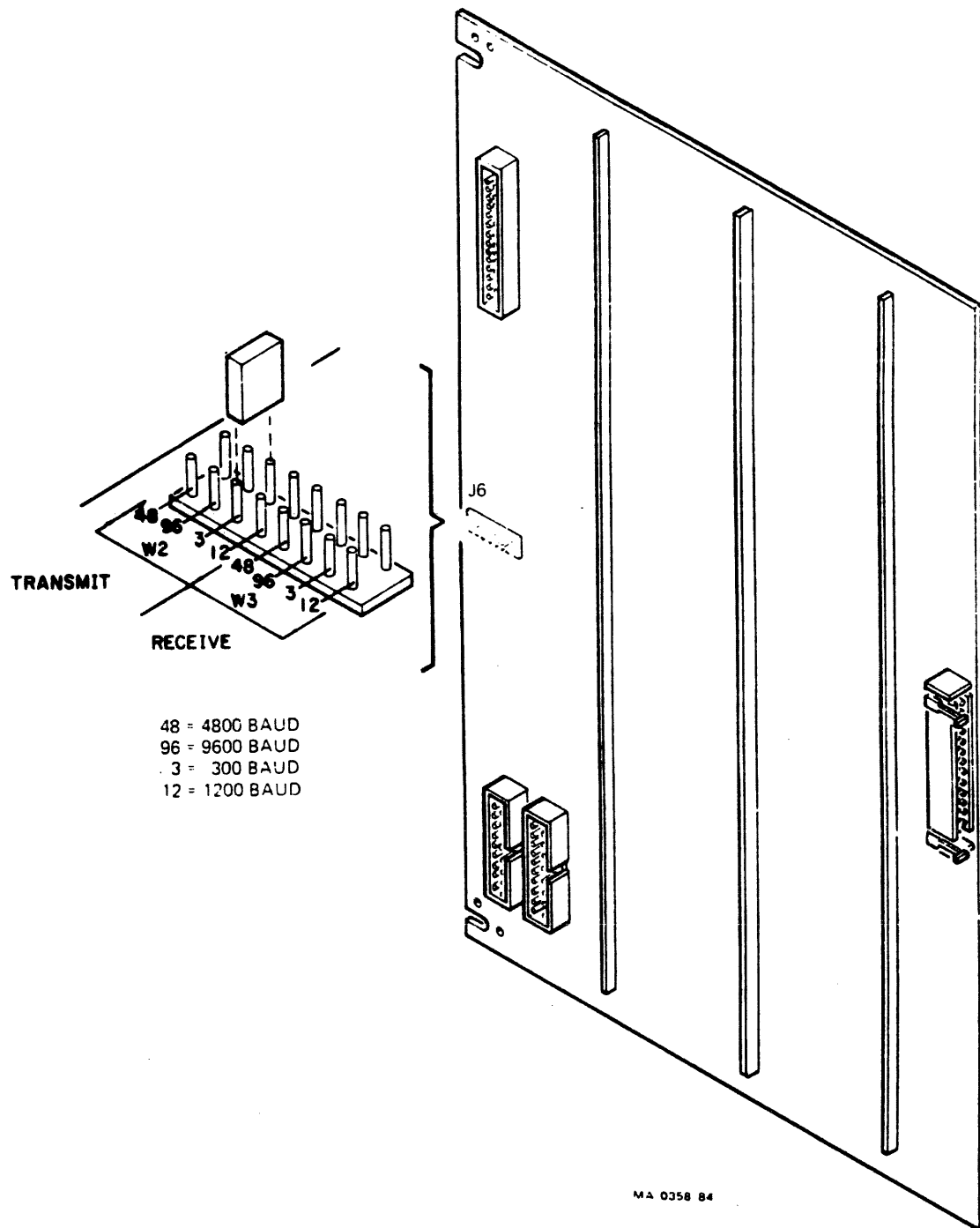

Figure B-4. TMSCP INTERFACE MODULE - JUMPER LOCATIONS

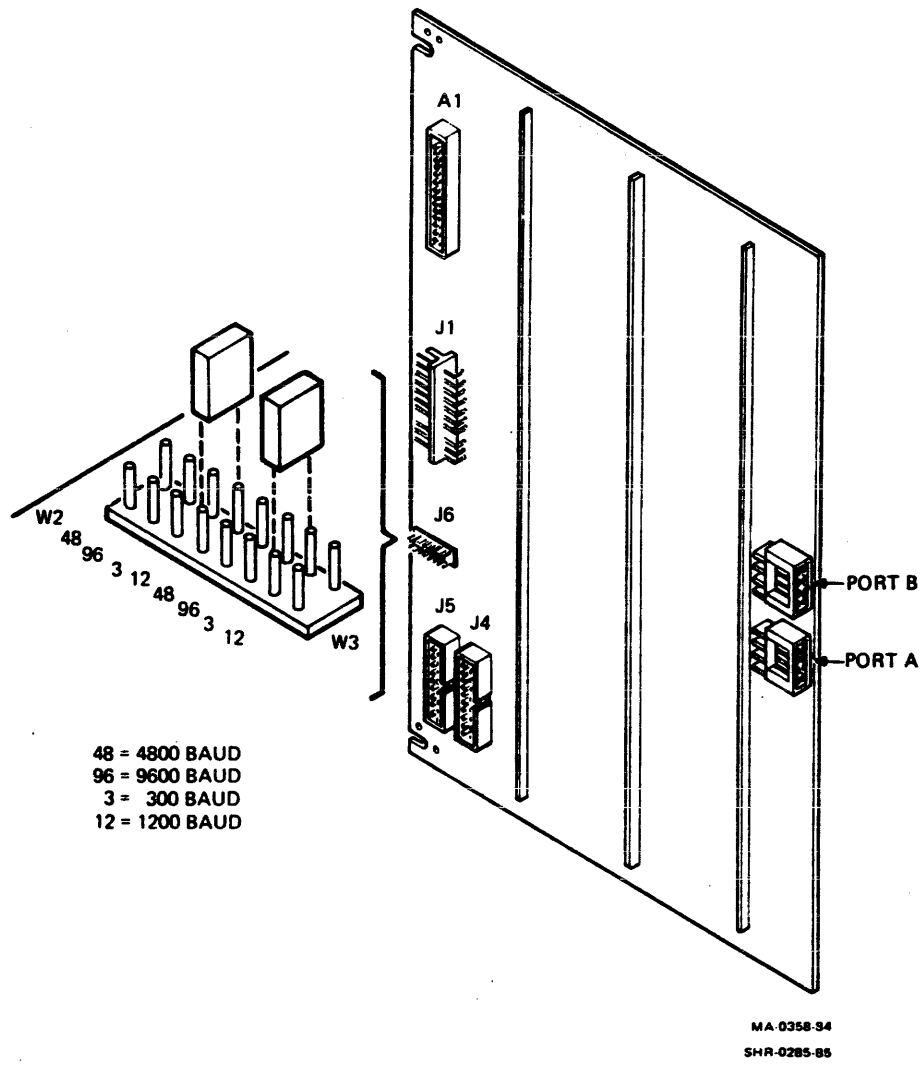

Figure B-5. STI INTERFACE MODULE - JUMPER LOCATIONS

APPENDIX C

Table C-1. RELATED DOCUMENTS

TU81/TA81 Subsystem User Guide	EK-TUA81-UG	Contains functional and system overview, installation, operation, and user maintenance information.
TU81/TA81 Pathfinder	EK-TUA81-SV	Provides test documentation (troubleshooting procedures, diagnostic tests, fault and sub-fault codes) for use by trained service personnel.
TU81/TA81 Illustrated Parts Breakdown	EK-TUA81-IP	Lists and illustrates TU81/TA81 assemblies and replaceable parts.
TU81 Magnetic Tape Subsystem Pocket Service Guide	EK-0TU81-PS	Provides a quick reference to installation, maintenance, and repair procedures for trained service personnel.
TA81 Magnetic Tape Subsystem Maintenance Guide	AA-2786A-TC	As a part of the HSC50 Service Manual, gives a quick reference to installation, maintenance, and repair procedures for trained service personnel.
874 Power Controller IPB	EK-00874-IP	
TU81 Field Maintenance Print Set	MP-01618	
TA81 Field Maintenance Print Set	MP-02027	
TU81-E Field Maintenance Print Set	MP-02060	

Appendix D - TA81 SYSTEM INTERFACE

D.1 STI OVERVIEW

The TA81 tape subsystem conforms to DIGITAL Standard Tape Interface (STI) protocol. STI is an asynchronous communications protocol used by a family of tape mass storage device controllers. Commands and responses are exchanged between the HSC and STI interface by messages structured with a general format. Data I/O is performed between a host and the HSC over the CI bus; data I/O is performed between the HSC and the STI interface module (installed in the TA81) over the STI bus. The STI interface module contains the intelligence under microprocessor control to convert these messages to TA81 device specific commands and responses. The STI concept allows future devices to be interfaced to the HSC without requiring new HSC-based driving software.

LEGAL NOTICE

TMSCP and STI protocols and documentation are the proprietary information of Digital Equipment Corporation. UNIBUS/Q-BUS/BI-BUS port drivers and documentation for MSCP/TMSCP products are also proprietary information of Digital Equipment Corporation.

D.2 SUBSYSTEM OVERVIEW

Figure D-1 is a block diagram of the TA81 subsystem. The tape transport is directly connected to up to two HSCs by an STI interconnect. A Tape Data Channel (TDC) installed in the HSC connects the HSC to the STI bus.

The STI module contains the interface to the STI bus, the interface to the formatter, and the microprocessor-based intelligent controller. The interface fetches and translates HSC-transmitted command messages to TA81 formatter commands. It also encodes TA81 formatter and drive status into messages and delivers them to the HSC. In addition, it supervises bi-directional data transfer between the HSC and the unit.

The tape drive is the physical transport itself with the read/write electronics, servo control and panel switches. For purposes of STI definition, the formatter and drive are defined as the "unit," the TDC module as the "controller," and the STI module as the "formatter."

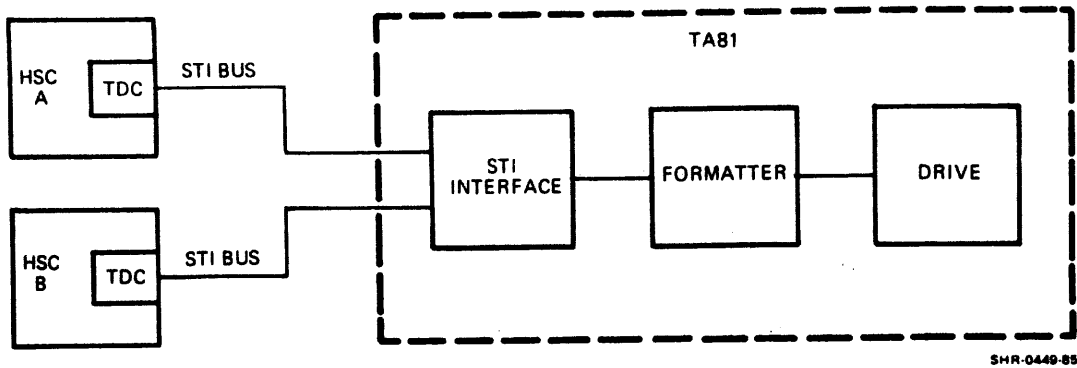

Figure D-1. SUBSYSTEM BLOCK DIAGRAM

D.3 STI BUS OVERVIEW

The STI bus carries signals between the controller and formatter.

The STI bus consists of four uni-directional lines. It is a serial bus; all control, data, command, and response signals are sent serially through these lines. The lines are shown in Figure D-2, the STI Interface Block Diagram.

Two of the lines carry signals from the controller to the formatter. One is a control line; the other carries commands and data to be written to the tape.

The other two lines carry signals from the formatter to the controller. One is a control line; the other carries responses and data that has been read from the tape.

D.4 STI COMMUNICATIONS

Since STI signals are carried on serial lines, pulses received on a line are grouped into "packets" so that they can be interpreted.

For example, pulses carried on the control lines are grouped into 16-bit packets; these are called "state" frames. Pulses carried on the command and data line or response and data line are grouped into 32-bit packets; these packets form "message" frames. Information provided by each type of frame is discussed in the following paragraphs.

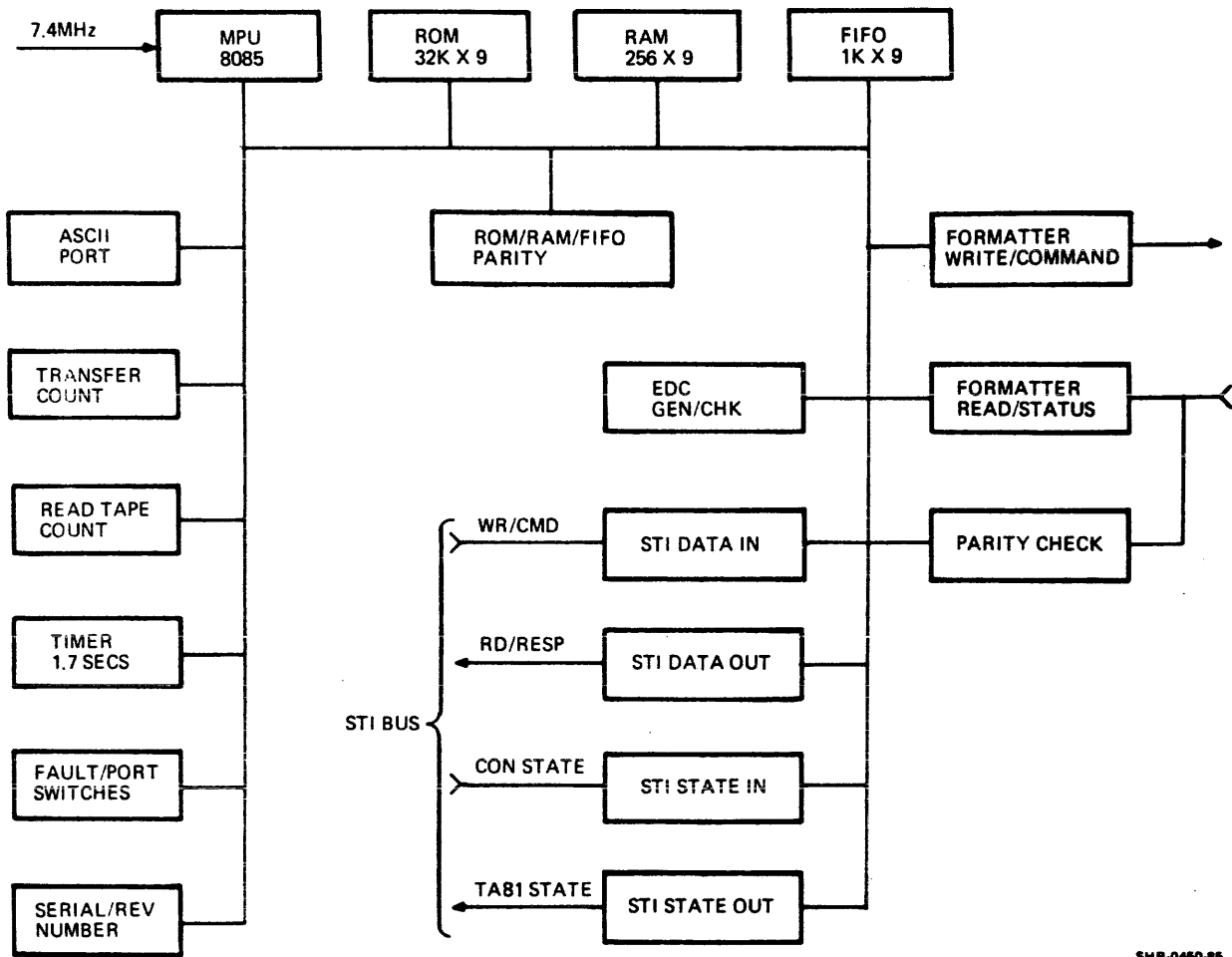

SHR-0450-85

Figure D-2. STI INTERFACE MODULE BLOCK DIAGRAM

D.4.1 STATE FRAMES

A state frame is a 16-bit packet that is carried on either of the control lines on the STI bus.

A state frame on the control line coming from the controller to the formatter provides the following information.

- o Controller Receiver Ready - Indicates when the controller is ready to receive a message frame.
- o Keep Going - Indicates that the controller will send another read or write command, so it wants the drive to stay in streaming mode.

- o Clock Slow - Tells the formatter to decrease its clock to below 8.8 MHz. This is a temporary condition; when the controller negates this signal, the formatter can resume transmission at its previous rate.

NOTE

The TA81 subsystem is self-clocking. The controller uses the formatter's clock to match the transfer rate of the drive. This allows the STI bus to accommodate the range of transfer rates used by different tape drives.

- o Initialize - Used by the controller to resynchronize communications between the controller and the formatter.

A state frame on the control line coming from the formatter to the controller provides the following information.

- o Formatter Receiver Ready - Indicates when the formatter is ready to receive a message frame.
- o Attention - Indicates that the formatter requires the controller's attention because the formatter's status has changed.
- o Acknowledge - Indicates that a data transfer has been successfully completed.
- o Data Ready - Indicates that data that has been read from the tape is ready to be sent to the controller, or that the formatter is ready to receive data to be written to the tape.
- o Available - Used by the controller to determine which of the following connection states the drive is in.

On-line State

Formatter enters this state from the available state when it becomes dedicated to one controller. The formatter must be in this on-line state for data transfers to take place.

Off-line State

Formatter is not able to communicate with a controller or perform any data transfers. A formatter can be off-line to all connected controllers due to a power failure or error condition; the formatter can be off-line to one of its controllers if the port switch that connects it to that controller is disabled.

Available State

Formatter is not dedicated to any controller. The formatter sends this state continuously to all selected controllers. When the formatter receives a valid command, it enters the on-line state.

Unavailable State

Formatter is unavailable to one controller when it is on-line to another controller.

- o Parity - Provides odd parity check of the other state signals in the frame.

D.4.2 MESSAGE FRAMES

A message frame is a 32-bit packet that is carried on the command and data line or the response and data line on the STI bus.

A frame on the command and data line coming from the controller to the formatter tells the formatter what operation the host wants the unit to perform. The entire command may take several frames: one frame provides the opcode for the operation, as many as 62 frames list the parameters for the operation, and a final frame provides a checksum. The same command and data line is used to send data from the controller to the formatter when a write operation is performed.

A frame on the response and data line coming from the formatter to the controller tells the controller the result of the previous operation. The same response and data line is used to send data from the formatter to the controller when a read operation is performed.

Figure D-3 provides the STI Data Control Block Diagram.

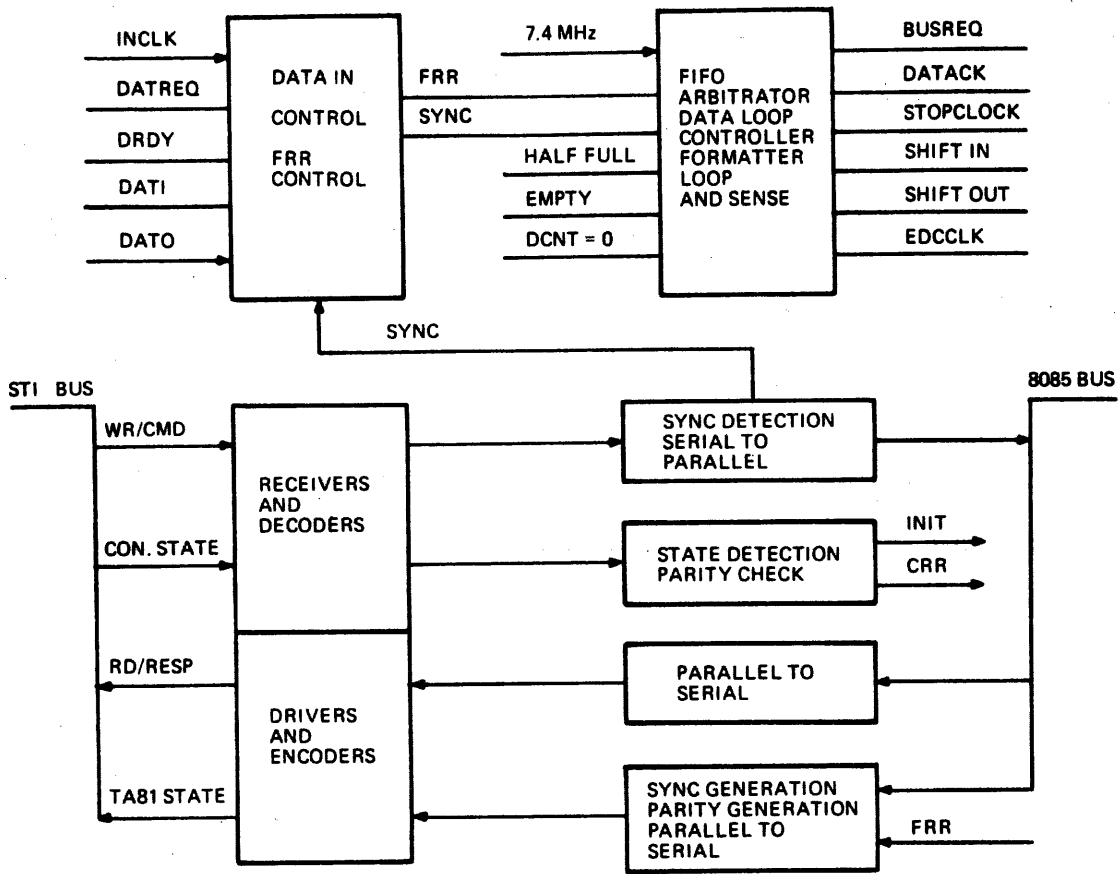

SHR-0451-85

Figure D-3. STI DATA CONTROL BLOCK DIAGRAM